

DPCM – DCT FOR SATELLITE IMAGE COMPRESSION

Khaled SAHNOUN¹, Nouredine BENABADJI²

^{1,2}Laboratory of Analysis and Application of Radiation (LAAR)

Department of Physics, University of Sciences and Technology of Oran (USTOMB)

B.P. 1505, El M'nouar, 31024, ORAN, Algeria

¹sahnounkhaled@hotmail.fr

²benanour2000@yahoo.com

Abstract: There are many ways to encode, represent, and compress satellite images. Today, with the huge technological advance, algorithms are used to perform many calculations to compress and decompress a satellite image. The future of the compression can take place only through mathematical algorithms, and the progress of mathematical research undoubtedly will lead to an advance in image and file compression. In this paper, we propose a hybrid DPCM-DCT predictive coding and discrete cosine transform DCT and, run-length encoding (RLE) for satellite image compression.

Keywords: Compression, satellite images, DCT, DPCM.

1. INTRODUCTION

In this work we develop the basic techniques used in our implementation are the DPCM predictive coding (the differential pulse coded modulation) combined with the DCT (the discrete cosine transformed) and Huffman coding. At first, we present the principle of predictive image coding DPCM; we also present the basic concept of the discrete cosine transformed DCT and Huffman coding.

2. BASIC PRINCIPLE

2.1 The differential pulse code modulation DPCM

The variable x represents the input signal, and r represents the difference between a predicted value and x . Successive samples are correlated, it is possible to predict the sample $n+1$ from samples n , and also $n-1$, $n-2$, etc. We can therefore encode the difference between a sample In and prediction of In . In the case of DPCM coding the prediction In is simply the value of the previous sample $In - 1$. The basic idea is provide information in each satellite image pixel, and to make the expected image entropy unless the original image entropy [1]. We fix, for example A, B, C and D, This returns for averaging the values of four neighboring pixels. Only the value of the difference is transmitted which then allows a significant gain [2], watch figure 1. The diagram of the encoding / DPCM is given figure 2.

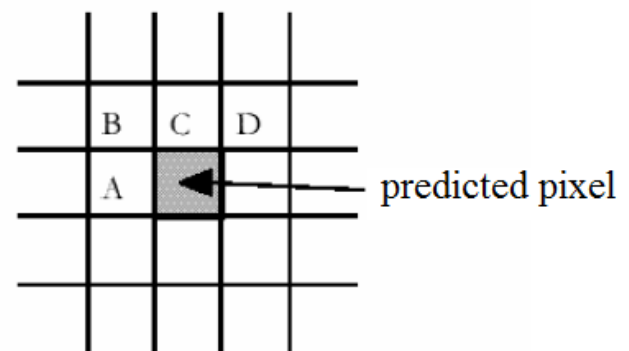

Fig. 1. Predictor Model

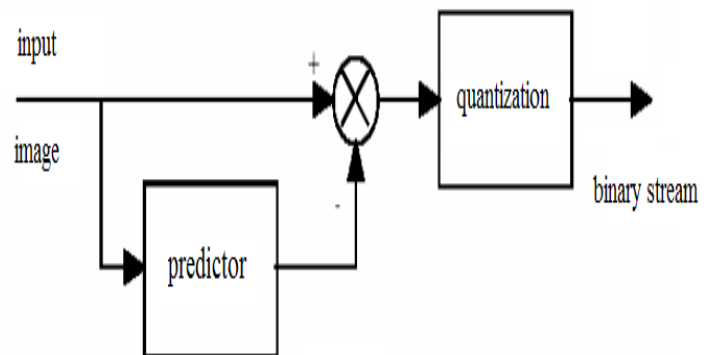

Fig. 2. Diagram of encoding DPCM

2.2 The discrete cosine transform (DCT)

All compression methods based on the Discrete Cosine Transform (DCT) following three steps, transformation of the difference image or predicted, quantizing and encoding the transformed coefficients [3]. The transformation is applied on blocks of $8*8$ (pixels) and is defined by:

$$f(u, v) = \frac{2c(u)c(v)}{n} \sum_{x=0}^{n-1} \sum_{y=0}^{n-1} f(x, y) \cos(2x + 1) \frac{u\pi}{2n} \cos(2y + 1) \frac{v\pi}{2n}$$

With $c(0) = \frac{1}{\sqrt{2}}$ and $c(u) = 1$ if $u \neq 0$. (1)

N is the block size ($N = 8$ is selected), x, y are the coordinates in the spatial domain and u, v coordinates in the frequency

domain. Each block is composed of 64 coefficients. The coefficient (0.0) is denoted by DC and represents the average intensity of the block, others are denoted AC. The coefficients with the global information of the image are located in low frequency while those in the higher frequencies are often similar to noise [4].

2.3 The quantization

The quantization step is the only part of the irreversible compression process. It was she who led the losses during compression [5]. An optimization method could be adapted to quantify the image, rather than defining a quantization identical for all images. This adjustment can be performed using the statistical characteristics of the DCT coefficients. Thus, it must be optimized to improve both the compression ratio and keep a good image reproduction. Quantization is realized on 8*8 blocks of transformed coefficients: each of the 64 DCT coefficients is quantized by a uniform quantifier defined by:

$$FQ(u, v) = \text{arrondi } f(u, v) / Q(u, v) \quad (2)$$

$FQ(u, v)$ Is the quantized DCT coefficients, $Q(u, v)$ the element of the luminance array, "arrondi" is the nearest integer.

2.4 Coding

The quantized matrix is now ready for the finale step of compression before storage, all coefficients of quantized matrix are converted by run-length encoding (RLE) to a stream of binary data after quantization it is quite common for most of the coefficients to equal zero. DCT takes advantages of this by encoding quantized coefficients in the Zig-Zag [6] sequence, the advantage lies in this consolidation of relatively large runs of zeros, which compress very well.

2.5 Diagram of the proposed method

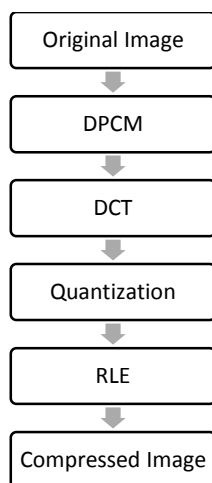

Fig. 3. The steps of the proposed method

2.6 Experimental results and discussion

The algorithm realized in C++ Builder v6.0 to code and to decode an image excerpt from the satellite SPOT showing the east coast of Oran region, and the Lena image of size 256 X 256. The compression ratios and the PSNR values obtained for the reconstructed Len image, Satellite image is listed in Table 1. The original image and the decompression image after DPCM, DCT, and run length encoding and decoding is shown in Figure 4, 5 and Figure 6, 7.

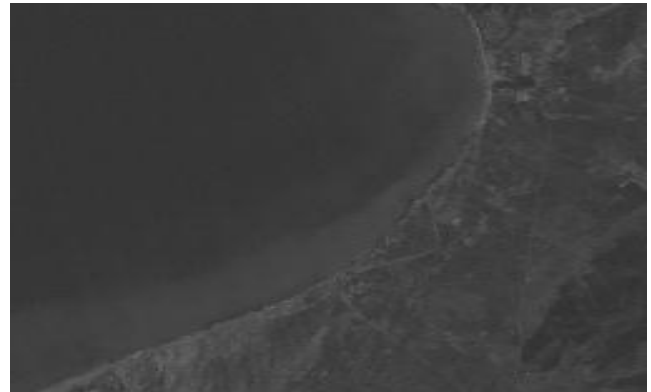

Fig. 4. Original satellite image

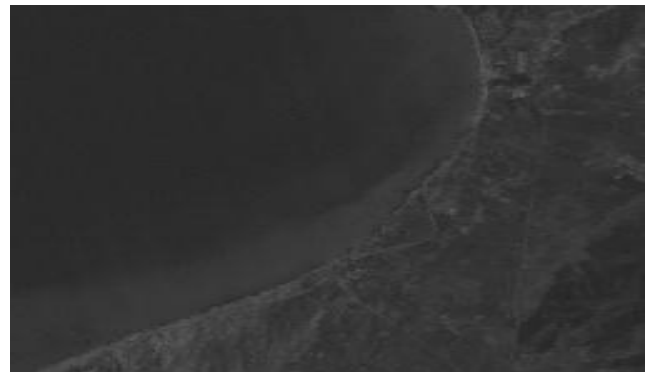

Fig. 5. Satellite image reconstructed



Fig. 6. Original Lena image



Fig. 7. Reconstructed Lena image

Chouduri, "A Pipelined Architecture Algorithm for Image Compression", Proc. Data Compression Conference, Saltlake City, USA, March 1997.

[6] Sami Khuri and Hsiu-Chin Hsu "Interactive Packages for Learning Image Compression Algorithms" lists, requires prior specific permission and/or a fee. ITiCSE 2000, Helsinki, Finland

Image	PSNR(db)	CR
Lena	29.81	69.84
Satellite image	30.24	73.64

Table 1: the compression ratios (CR) and PSNR values for satellite and Lena picture.

The values in the table show that the compression rate possible for satellite imaging higher compared to the standard image Lena.

3. CONCLUSION

In this paper we applied the predictive coding DPCM and discrete cosine transformed DCT with RLE encoding to compress a satellite image. After applying the proposed approach, we can see acceptable results for Lena image and satellite picture.

BIBLIOGRAPHY:

- [1] G. P. Abousleman, M. W. Marcellin, and B. R. Hunt, "Compression of hyperspectral imagery using the 3-D DCT and hybrid DPCM/DCT," IEEE Transactions on Geoscience and Remote Sensing, vol. 33, no. 1, pp. 26-34, January 1995.
- [2] S. K. Bandyopadhyay, T. U. Paul, A. raychoudhury "image compression using approximate matching and run length" International journal of advanced computer and application, vol.2, No.6, pages 117-121, 2006.
- [3] W. B. Pennebaker and J. L. Mitchell, "JPEG: Still Image Data Compression Standard", Van Nostrand Reinhold, New York, 1993.
- [4].A. Skodras, C. Christopoulos, and T. Ebrahimi, "The JPEG 2000 still image compression standard," IEEE Signal Processing Magazine, vol. 18, no. 5, pp. 36-58, September 2001.
- [5] S. Bhattacharjee, S. Das, D. Roy Choudhury and P. Pal