

REVIEW AND SIMULATION OF SOLAR-WIND HYBRID SYSTEM WITH SMART GRID INTEGRATION

Pratik Prajapati¹, R.P.Sukhadiya²

¹PG Scholar, Electrical Department, LDRP-ITR, Gandhinagar, Gujarat, India

²Assisatnt Professor, , Electrical Department, LDRP-ITR, Gandhinagar, Gujarat, India

Abstract: *Rapid depletion of fossil fuel resources on a worldwide basis has necessitated an urgent search for alternative energy sources to cater to the present days' demand. The electric power generation system, which consists of renewable energy and fossil fuel generators together with an energy storage system and power conditioning system, is known as a hybrid power system. A hybrid power system has the ability to provide 24 hour grid quality electricity to the load. This system offers a better efficiency, flexibility of planning and environmental benefits compared to the diesel generator stand-alone system. This Paper focuses on the combination of solar wind systems for sustainable power generation. The solar energy also varies with the hourly, daily and seasonal variation of solar irradiation. The wind turbine output power varies with the wind speed at different conditions. However, a drawback, common to solar irradiation and wind speed options, is their unpredictable nature and dependence on weather and climatic changes, and the variations of solar and wind energy may not match with the time distribution of load demand. This shortcoming not only affects the system's energy performance, but also results in batteries being discarded too early.*

I. INTRODUCTION

Rapid depletion of fossil fuel resources on a worldwide basis has necessitated an urgent search for alternative energy sources to cater to the present days' demand. . Therefore, it is imperative to find alternative energy sources to cover the continuously increasing demand of energy while minimize the negative environmental impacts Recent research and development of alternative energy sources have shown excellent potential as a form of contribution to conventional power generation systems. There is a huge potential for utilizing renewable energy sources, for example solar energy, wind energy, or micro-hydropower to provide a quality power supply to remote areas. The abundant energy available in nature can be harnessed and converted to electricity in a sustainable way to supply the necessary power demand and thus to elevate the living standards of the people without access to the electricity grid.

The advantages of using renewable energy sources for generating power in remote islands are obvious such as the cost of transported fuel are often prohibitive fossil fuel and that there is increasing concern on the issues of climate change and global warming. The electric power generation system, which consists of renewable energy and fossil fuel generators together with an energy storage system and power conditioning system, is known as a hybrid power system. A

hybrid power system has the ability to provide 24 hour grid quality electricity to the load. This system offers a better efficiency, flexibility of planning and environmental benefits compared to the diesel generator stand-alone system. The maintenance costs of the diesel generator can be decreased as a consequence of improving the efficiency of operation and reducing the operational time which also means less fuel usage. The system also gives the opportunity for expanding its capacity in order to cope with the increasing demand in the future. This can be done by increasing either the rated power of diesel generator, renewable generator or both of them. The disadvantage of standalone power systems using renewable energy is that the availability of renewable energy sources has daily and seasonal patterns which results in difficulties of regulating the output power to cope with the load demand. Also, a very high initial capital investment cost is required. Combining the renewable energy generation with conventional diesel power generation will enable the power generated from a renewable energy sources to be more reliable, affordable and used more efficiently. Solar and wind energy systems are being considered as promising power generating sources due to their availability and topological advantages for local power generations in remote areas. This Paper focuses on the combination of solar wind systems for sustainable power generation. The solar energy also varies with the hourly, daily and seasonal variation of solar irradiation. The wind turbine output power varies with the wind speed at different conditions. However, a drawback, common to solar irradiation and wind speed options, is their unpredictable nature and dependence on weather and climatic changes, and the variations of solar and wind energy may not match with the time distribution of load demand. This shortcoming not only affects the system's energy performance, but also results in batteries being discarded too early.

II. SOLAR PV WORKING

There are several types of solar cells. However, more than 90 % of the solar cells currently made worldwide consist of wafer-based silicon cells. They are either cut from a single crystal rod or from a block composed of many crystals and are correspondingly called mono-crystalline or multi-crystalline silicon solar cells. Wafer-based silicon solar cells are approximately 200 μm thick. Another important family of solar cells is based on thin-films, which are approximately 1-2 μm thick and therefore require significantly less active, semiconducting material. Thin-film solar cells can be manufactured at lower cost in large production quantities; hence their market share will likely increase in the future.

However, they indicate lower efficiencies than wafer-based silicon solar cells, which mean that more exposure surface and material for the installation is required for a similar performance. A number of solar cells electrically connected to each other and mounted in a single support structure or frame is called a 'photovoltaic module'. Modules are designed to supply electricity at a certain voltage, such as a common 12 volt system. The current produced is directly dependent on the intensity of light reaching the module. Several modules can be wired together to form an array. Photovoltaic modules and arrays produce direct-current electricity. They can be connected in both series and parallel electrical arrangements to produce any required voltage and current combination.

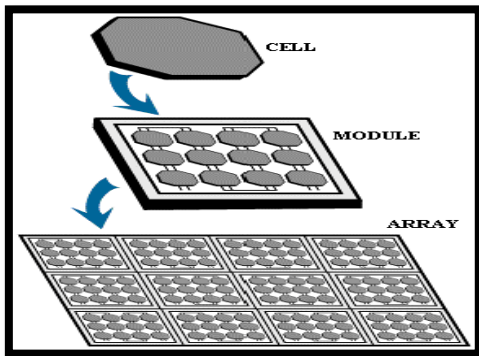

Figure -1 Electrical Connection of the cells

The electrical output of a single cell is dependent on the design of the device and the semi-conductor material(s) chosen, but is usually insufficient for most applications. In order to provide the appropriate quantity of electrical power, a number of cells must be electrically connected. There are two basic connection methods: series connection, in which the top contact of each cell is connected to the back contact of the next cell in the sequence, and parallel connection, in which all the top contacts are connected together, as are all the bottom contacts. In both cases, this results in just two electrical connection points for the group of cells.

Series connection:

Figure-2 shows the series connection of three individual cells as an example and the resultant group of connected cells is commonly referred to as a series string. The current output of the string is equivalent to the current of a single cell, but the voltage output is increased, being an addition of the voltages from all the cells in the string (i.e. in this case, the voltage output is equal to 3V_{cell}).

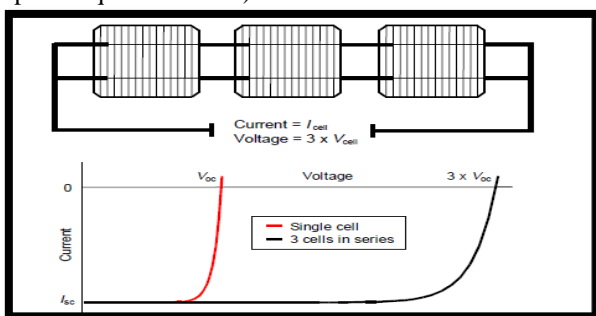

Figure-2 Series connection of cells, with resulting current–voltage characteristic

It is important to have well matched cells in the series string, particularly with respect to current. If one cell produces a significantly lower current than the other cells (under the same illumination conditions), then the string will operate at that lower current level and the remaining cells will not be operating at their maximum power points.

Parallel connection

Figure-3 shows the parallel connection of three individual cells as an example. In this case, the current from the cell group is equivalent to the addition of the current from each cell (in this case, 3 I_{cell}), but the voltage remains equivalent to that of a single cell.

As before, it is important to have the cells well matched in order to gain maximum output, but this time the voltage is the important parameter since all cells must be at the same operating voltage. If the voltage at the maximum power point is substantially different for one of the cells, then this will force all the cells to operate off their maximum power point, with the poorer cell being pushed towards its open-circuit voltage value and the better cells to voltages below the maximum power point voltage. In all cases, the power level will be reduced below the optimum..

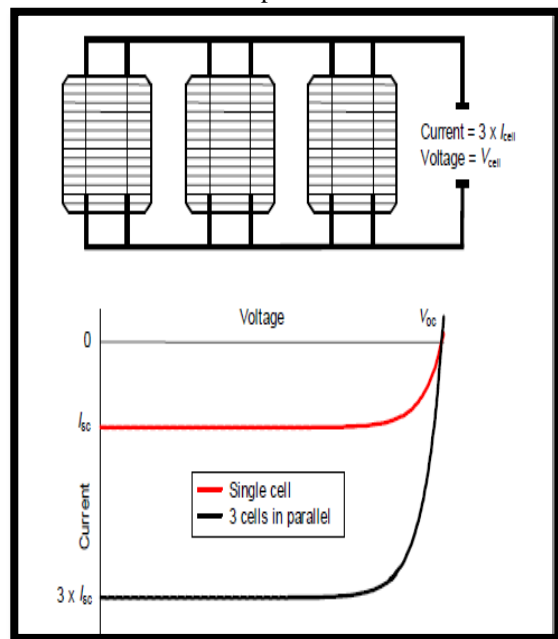

Figure Error! No text of specified style in document. Parallel connection of cells, with resulting current–voltage characteristic

III. WIND POWER

Wind is abundant almost in any part of the world. Its existence in nature caused by uneven heating on the surface of the earth as well as the earth's rotation means that the wind resources will always be available. The conventional ways of generating electricity using non renewable resources such as coal, natural gas, oil and so on, have great impacts on the environment as it contributes vast quantities of carbon dioxide to the earth's atmosphere which in turn will cause the temperature of the earth's surface to increase, known as the green house effect. Hence, with the advances in science and technology, ways of generating electricity using

renewable energy resources such as the wind are developed. Nowadays, the cost of wind power that is connected to the grid is as cheap as the cost of generating electricity using coal and oil. Thus, the increasing popularity of green electricity means the demand of electricity produced by using non renewable energy is also increased accordingly.

Wind Turbines

There are two types of wind turbine in relation to their rotor settings. They are:

- Horizontal-axis rotors, and
- Vertical-axis rotors.

In this report, only the horizontal-axis wind turbine will be discussed since the modelling of the wind driven electric generator is assumed to have the horizontal-axis rotor. The horizontal-axis wind turbine is designed so that the blades rotate in front of the tower with respect to the wind direction i.e. the axis of rotation are parallel to the wind direction. These are generally referred to as upwind rotors. Another type of horizontal axis wind turbine is called downwind rotors which has blades rotating in back of the tower. Nowadays, only the upwind rotors are used in large-scale power generation and in this report, the term .horizontal-axis wind turbine refers to the upwind rotor arrangement.

The main components of a wind turbine for electricity generation are the rotor, the transmission system, and the generator, and the yaw and control system. The following figures show the general layout of a typical horizontal-axis wind turbine, different parts of the typical grid-connected wind turbine, and cross-section view of a nacelle of a wind turbine.

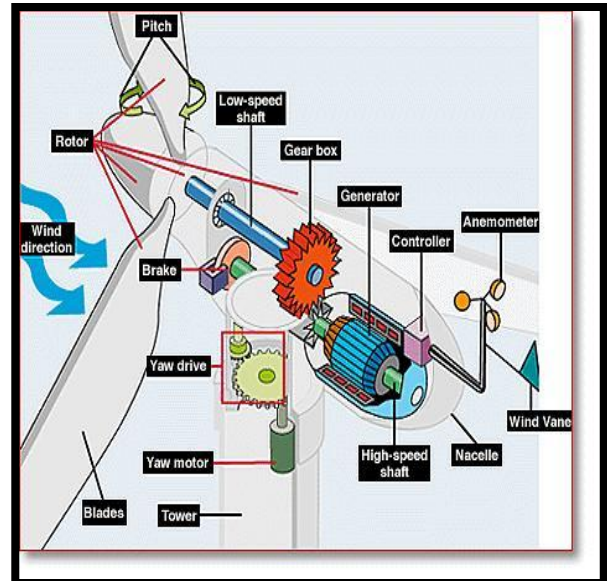

Figure 5 The Main component of a Wind Turbine can be classified as i) Tower ii) Rotor System iii) Generator iv) Yaw v) Control System vi) Breaking and Transmission System

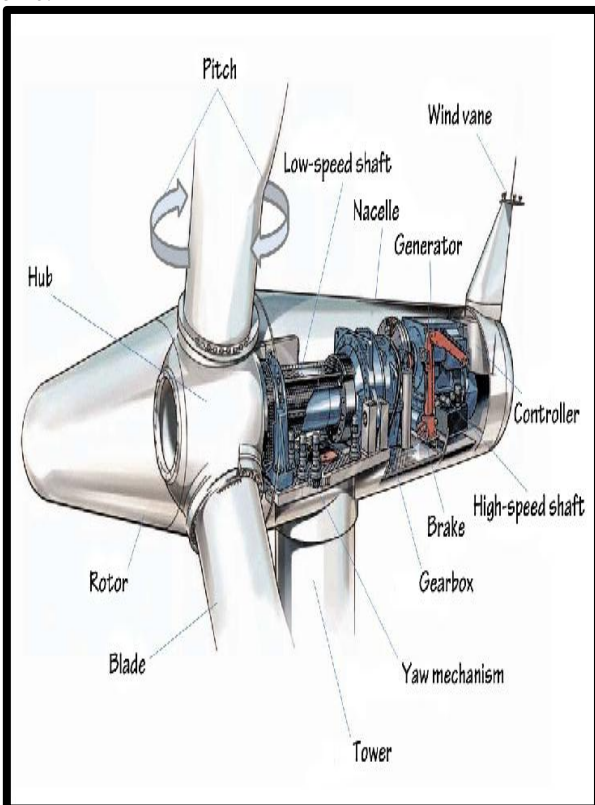

Figure Error! No text of specified style in document. Major Component of Wind Turbine

IV. HYBRID OPERATION AND SMART GRID Hybrid Power Generation System

A typical hybrid system combines two or more energy sources, from renewable energy technologies such as PV-panels, wind or small hydro turbines; and from conventional technologies usually diesel Generator sets. In addition, it includes power electronics and electricity storage bank. Our proposed hybrid system is designed for both on grid and off grid operation to reduce dependency on the national grid for electrical supply. The “fig.” shows the block diagram of a typical hybrid grid connected power system. The system consists of PV generators, wind generator, biogas, biomass (rice husk), micro-hydro, battery bank, battery charge controller and the dump load.

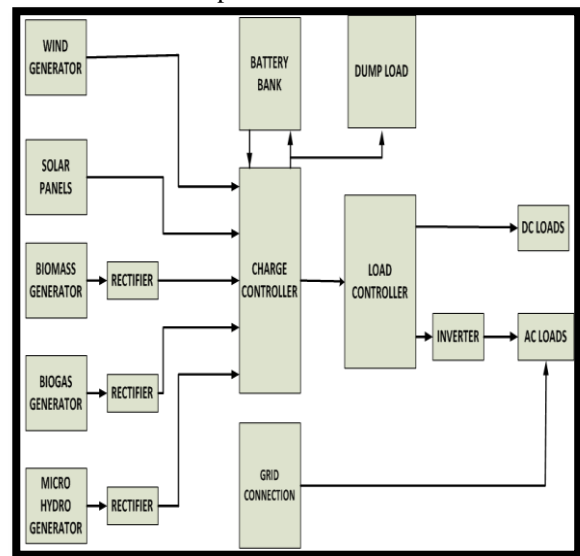
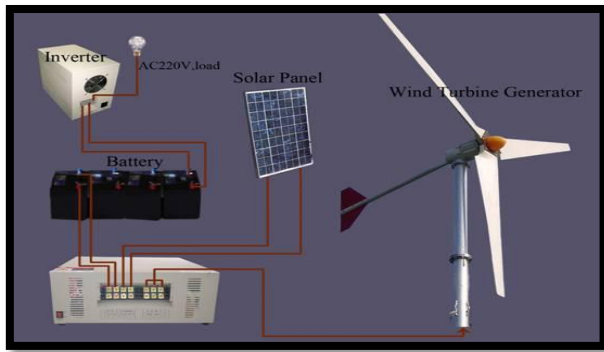
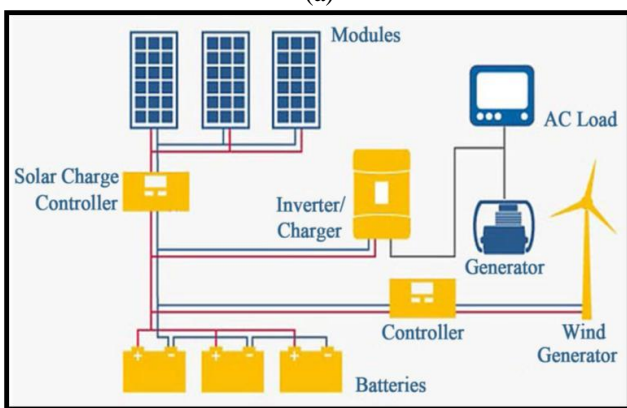

Figure 6 Basic Diagram of Hybrid System

In this project a hybrid system of solar-wind is considered. Here, we have different power generating units. Some of them generate AC and others DC power directly.



(a)



(b)

Figure 7 (a),(b) Solar-Wind Hybrid System

Grid Tie PV/ Wind Hybrid System

These systems can be classified in terms of their connection to the power system grid into the following:

Centralized AC-bus architecture

In this architecture, the generators and the battery are all installed in one place and are connected to a main AC bus bar before being connected to the grid. This system is centralized in the sense that the power delivered by all the energy conversion systems and the battery is fed to the grid through a single point. In this case, the power produced by the PV system and the battery is inverted into AC before being connected to the main AC bus.

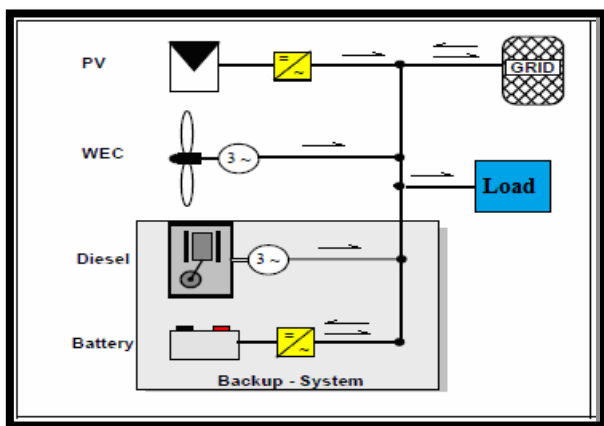

Figure 8 Centralized AC-bus architecture

Centralized DC-bus architecture

The second architecture utilizes a main centralized DC bus bar as in figure. The wind turbine and the diesel generator, firstly deliver their power to rectifiers to be converted into DC before it is being delivered to the main DC bus bar. A main inverter takes the responsibility of feeding the AC grid from this main DC bus.

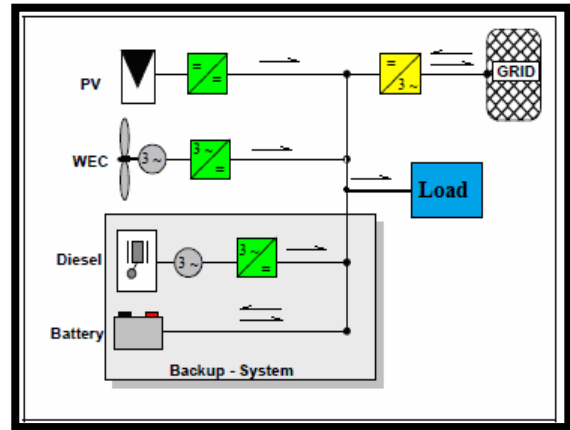

Figure 9 Centralized DC-bus architecture

V. PROPOSED WORK

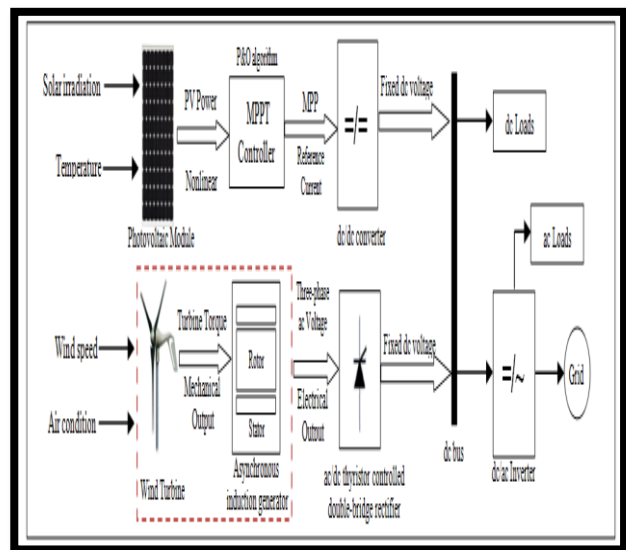

Figure 10 Block diagram of the proposed system

- Smart grid is a system consists of three layers: the physical power layer, the control layer and the application layer. And smart grid has to be dynamic and have constant two way communication as shown in fig.-7
- So for example, with PV panels on the roofs, intelligent building system will generates, store and use their own energy. Hence, as active buildings they become part of the smart grid.
- This could save energy and increase reliability and transparency. In this paper the dynamic simulation model is described for solar photovoltaic/wind turbine hybrid generation system.
- The developed system consists of a photovoltaic array, dc/dc converter with an isolated transformer,

designed for achieving the MPP with a current reference control (I_{ref}) produced by P&O algorithm, wind turbine, asynchronous induction generator, and ac/dc thyristor controlled double-bridge rectifier.

- The block diagram of the proposed system is shown in Fig.

Modelling and Simulation

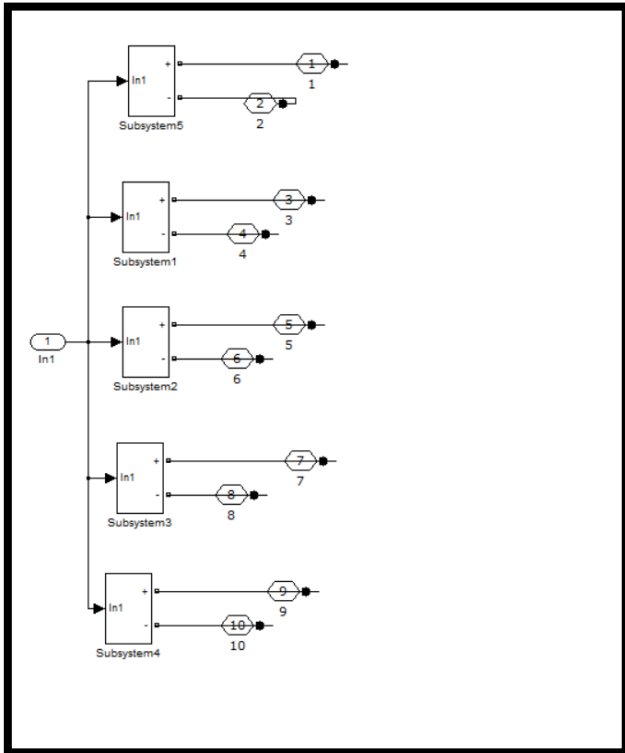

Solar PV System with MPPT and Boost converter
 Figure 11 Solar PV Array

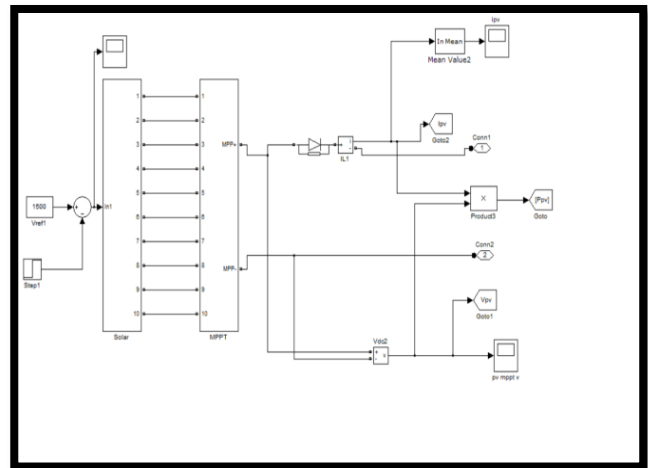

Figure 13 Solar PV array and MPPT

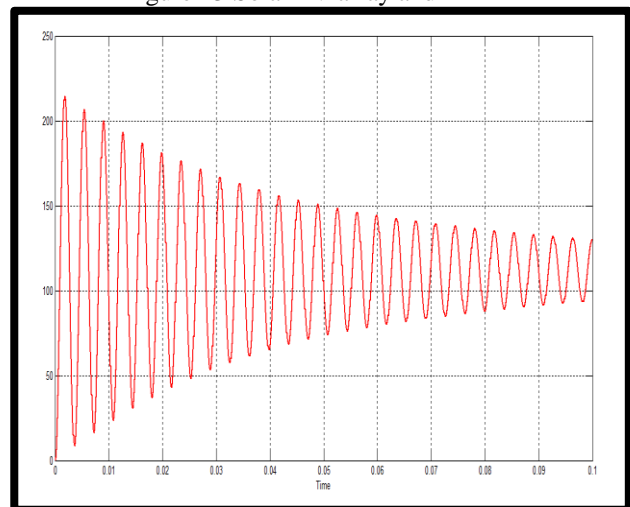

Figure 14 Solar Unstable D.C Output

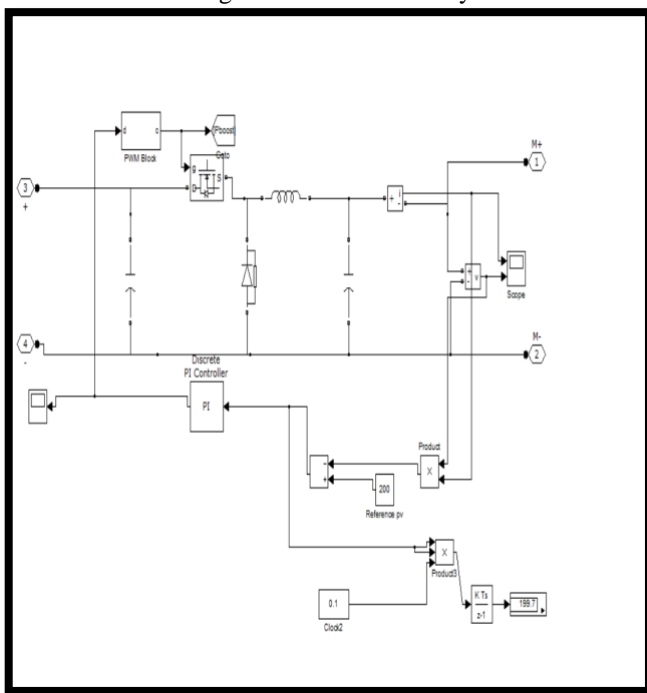

Figure 12 Solar MPPT and Boost converter System

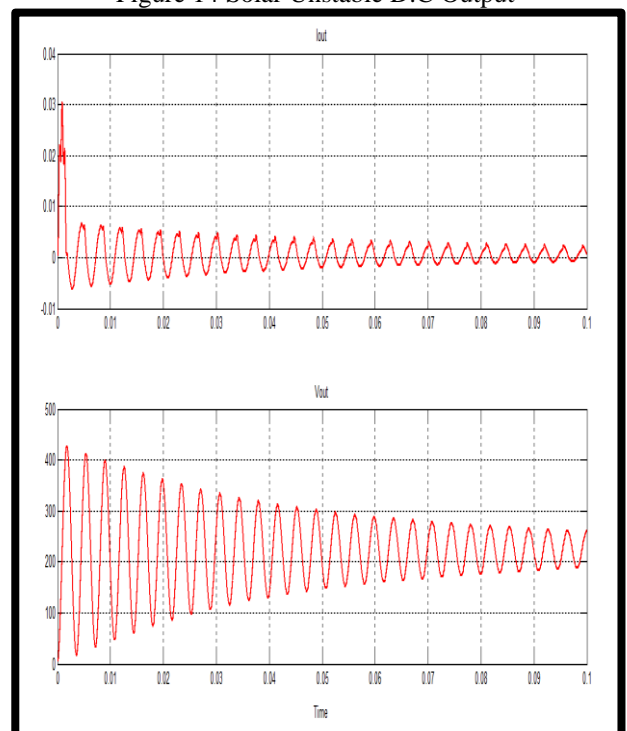

Figure 15 Solar Unstable Output

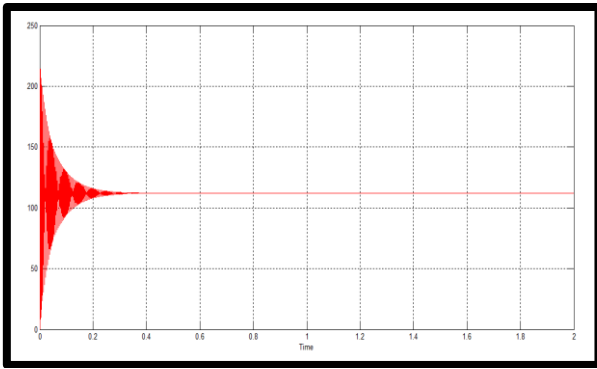

Figure 16 Solar D.C stable Output

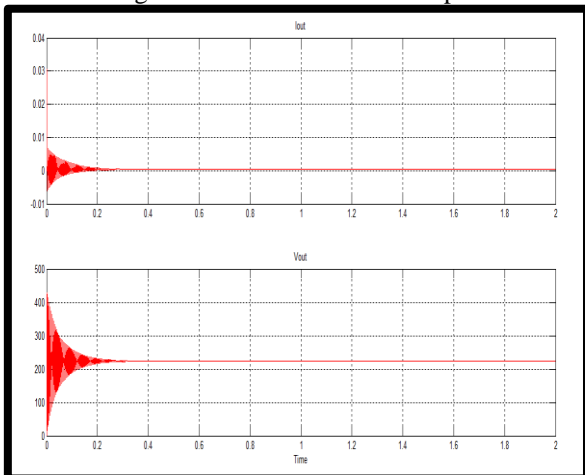

Figure 17 Stable output for Solar with MPPT

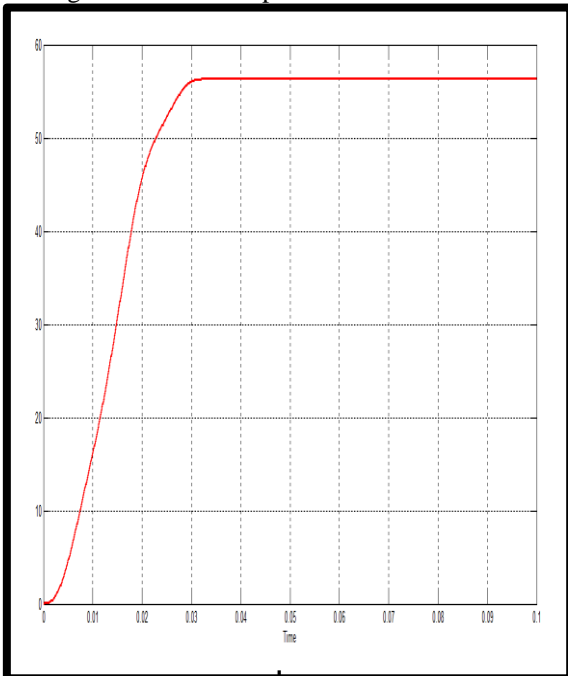

Figure 18 D.C Link Capacitor Voltage

Wind Simulation

The Matlab modelling of Induction Generator type wind power plant is shown in the fig 6.20 below. The simulation results shows the output voltage of wind turbine and also shows the different parameters output like Active and Reactive Power and other mechanical parameters also.

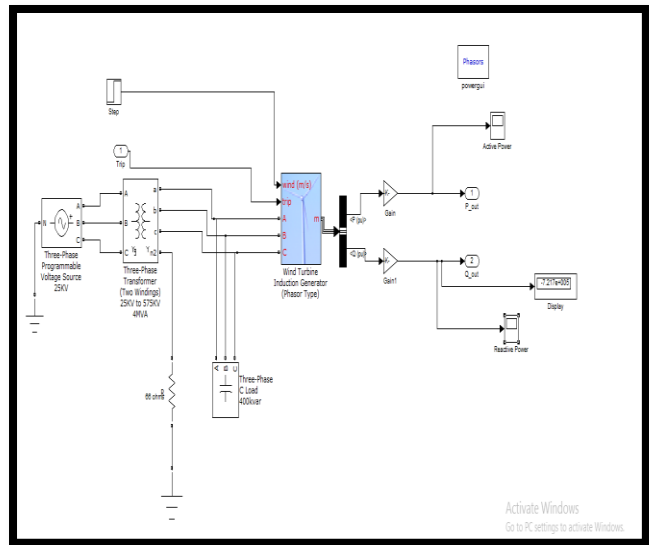

Figure 19 Wind Power Plant Simulation

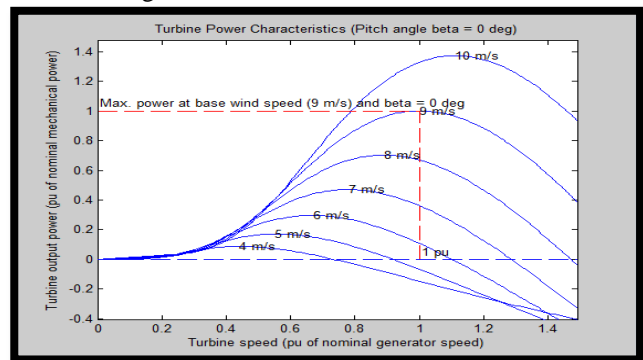

Figure 20 Mechanical Power and Turbine Speed

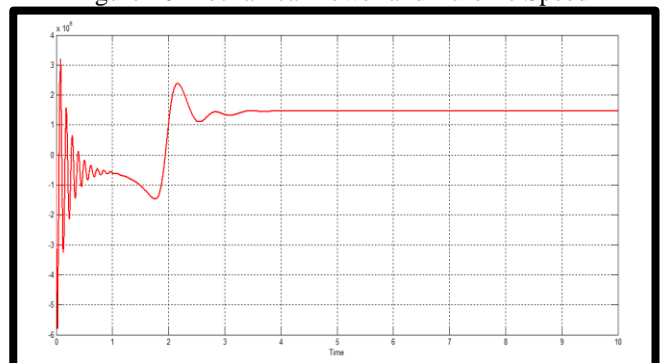

Figure 21 Output Active power

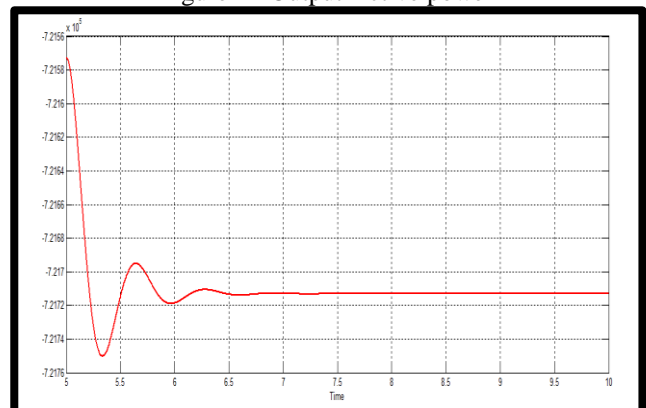

Figure 22 Output Reactive Power

VI. CONCLUSION

This paper presents a hybrid wind/PV energy system for standalone system. The standalone hybrid system is better than a single energy source. The wind energy systems may not be technically viable at all sites because of low wind speeds and being more unpredictable than solar energy. The combined utilization of these renewable energy sources is therefore becoming increasingly attractive. This Paper also highlights the future developments, which have the potential to increase the economic attractiveness of such systems and their acceptance by the user. This Project also represents the modeling and Simulation of Solar PV System using MATLAB-SIMULINK software. The Simulation results show the ideal I-V and P-V characteristics of the solar PV system. The wind power plant simulation and its three phase output voltage also shows in the simulation results.

REFERENCES

- [1] Modeling and Control for Smart Grid Integration of Solar/Wind Energy Conversion System, E. M. Natsheh, Member, IEEE, A. Albarbar, Member, IEE, and J. Yazdani, Member, IEEE
- [2] Modeling and Control for Smart Grid Integration with MPPT of Solar/Wind Energy Conversion System S. Sathish Kumar¹ , B.Swapna² , Dr.C.Nagarajan³ Research Scholar, GRT Institute of Engineering & Technology, Tamilnadu, India¹ Assistant Professor, Dept. of EEE, GRT Institute of Engineering & Technology, Tamilnadu, India² Professor, Dept. of EEE, Muthayammal College of Engineering, Tamilnadu, India
- [3] A Synchronized Wind-Solar Hybrid System for Future Smart Grids Haider Ali, Syed Wajid ALi Shah, Usman Khalid, M. Baseer and Najam us Saqib COMSATS Institute of I.T, Abbottabad, Pakistan.
- [4] PERFORMANCE ANALYSIS OF SMART GRID WITH SUPER CONDUCTING FAULT CURRENT LIMITER IN A SOLAR AND WIND BASED MICROGRID Avinash Chougule¹ , Dr. S. G. Kanade² 1ME Student, 2Professor Department of Electrical Engineering Tssm's bhivarabai sawant college of engineering and research, narhe Pune Hybrid Energy System and its Modelling in Smart Grid S.Ganesh kumaran^{#1} , Dr.S.Singaravelu* ² , K.vivekanandan.
- [5] Smart Grid Technologies Simulation Experience at Russky Island, A. Grobovoy, Member IEEE, A. Arestova, M. Khmelik, V. Shipilov, and Y. Nikitin
- [6] Smart Grids Technology Fundamentals- New Course Adel El Shahat Georgia Southern University, aahmed@georgiasouthern.edu Rami Haddad Georgia Southern University, rhaddad@georgiasouthern.edu Youakim Kalaani Georgia Southern University, yalkalaani@georgiasouthern.edu
- [7] Dynamic performance analysis of an integrated windphotovoltaic microgrid with storage, Lawrence K. Lettinga* , Josiah L. Munda , Yskandar Hamama a Tshwane University of Technology, Pretoria, South Africa
- [8] Maximum Power Generation by Integrating Solar & Wind System Using Fuzzy for Voltage Regulation in Smart Grid Priya .N1 , Saranya .C .M2 Department of Power System Engineering, Valliammai Engineering College, Chennai, India
- [9] Dynamic Modeling, Control and Simulation of a Wind and PV Hybrid System for Grid Connected Application Using MATLAB D. Mahesh Naik¹ , D. Sreenivasulu Reddy² , Dr. T. Devaraju³ ¹ (PG Student, Dept. of EEE, Sree Vidyanikethan Engineering College, Tirupati, Andhra Pradesh, India) ² (Assistant Professor, Dept. of EEE, Sree Vidyanikethan Engineering College, Tirupati, Andhra Pradesh, India) ³ (Professor & HOD, Dept. of EEE, Sree Vidyanikethan Engineering College, Tirupati, Andhra Pradesh, India)
- [10] Modeling and control of MPPT Based Grid Connected Wind-PV Hybrid Generation System S.Chandra Shekar PhD Scholar, Electrical and Electronics Engineering, Koneru Laxmaih University, Vijayawada, India, K.Raghu Ram Professor, Laqshya Institute of Technology and Sciences, Khammam, India
- [11] Systems and Control Opportunities in the Integration of Renewable Energy into the Smart Grid ? E. Bitar * P. P. Khargonekar ** K. Poolla **** E. Bitar is with the Department of Mechanical Engineering, U.C. Berkeley ebitar@berkeley.edu (corresponding author) ** P. P. Khargonekar is with the Department of Electrical and Computer Engineering, University of Florida ppk@ece.ufl.edu *** K. Poolla is with the Department of Electrical Engineering and Computer Science, U.C. Berkeley poolla@eecs.berkeley.edu
- [12] Modeling Grid Connection for Solar and Wind Energy P. J. van Duijsen, Simulation Research, The Netherlands Frank Chen, Pitotech, Taiwan
- [13] Simulation of A Solar and Wind Hybrid System Representating Distributed Fed Generators In Evolving Grids For Renewable System Kishan patel Department of Electrical Engineering, Merchant Engineering College, Basna
- [14] Modeling and Simulation of Photovoltaic Module and Array based on One and Two Diode Model Using Matlab/Simulink Ahmed Bouraiou a,b,*, Messaoud Hamoudaa ,Abdelkader Chakerb ,Mohammed Sadoka ,Mohammed Mostefaouia , Salah Lachtar
- [15] Development of Generalized Photovoltaic Model Using MATLAB/SIMULINK Huan-Liang Tsai, Ci-Siang Tu, and Yi-Jie Su, Member, IAENG