

# STRUCTURAL AND MODEL ANALYSIS ON SPLIT CASING OF A STEAM TURBINE

Borra Naga Raju<sup>1</sup>, R. Bhargavi<sup>2</sup>, D.Murali Krishna<sup>3</sup>  
<sup>1</sup>M. Tech Student, <sup>2</sup>Internal Guide, <sup>3</sup>Supporting Guide

Department of mechanical engineering, Usharama College Of Engineering & Technology  
 (NAAC “A” grade, Approved by A.I.C.T.E, Affiliated to J.N.T.U. Kakinada), TELAPROLU -521109,AP

**Abstract:** In general casings are manufactured (casted) as a single unit with single high grade steel material, but it is not necessary to use such a high performance grade material throughout the casing, because casing consist of different stages where casing is exposed to different conditions of pressure and temperature (it obviously decreases from initial stage to final stage). So the strength needed by the casing is different at different stages. So I plan to divide the casing on its horizontal axis into different parts (2 in number) and applying different materials for each part of the casing according to the strength needed by the casing at different regions i.e., we use general conventional material (high grade steel) at the first region and a lower grade material at the later regions. With this we can reduce the cost of casing predominantly.

## I. DESIGN

The design procedure adopted in the present work is as given below: Because of the very complicated shape of the turbine cylinder the exact calculation of the wall thickness becomes very difficult. Neglecting the effect of side walls, stiffening ribs, flanges, the pressure and temperature variation along the length, etc., we may consider the cylinder to be drum shaped.

s.no	description		value	units
1	casing thickness	tc	36.94	mm
2	flange height	h	107.13	mm
3	distance from bolt center to casing centre	m	352.47	mm
4	included angle between flange tip to casing centre	$\alpha$	19.34	mm
5	distance between bolt centre and Qy	s	47.26	mm
6	distance between bolt centre and Py	r	51.81	mm
7	distance between bolt centre and Px	c	51.24	mm
8	Dimension	x1	39.39	mm
9	Dimension	x2	35.16	mm

Inputs considered

## II. MATERIAL PROPERTIES

s.no	Material	Density (Kg/m <sup>3</sup> )	Youngs modulus (N/m <sup>2</sup> )	Passions ratio	Used at
1	Structural steel S235	7850	2e11	0.3	For Single casing , and part 1 in split casing
2	Structural steel S355	7850	1.9e11	0.29	For part 2 in split casing

## III. MODEL PREPARATION BY CATIA

Some of the steps in catia model preparation  
 step 1: Preparation Of 2D Drawing With Dimensions

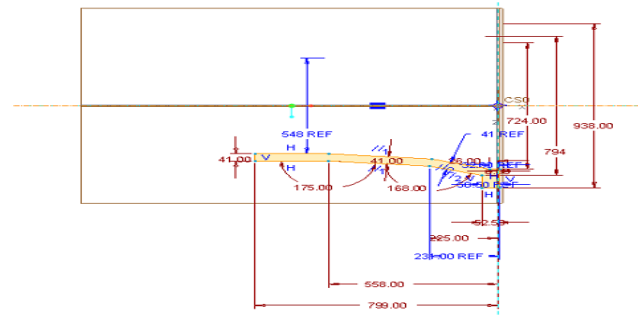

Fig 3.1: bottom half plane with dimensions

Step 2: Used Revolve Command To Make Bottom half of the casing (revolve by 1800)

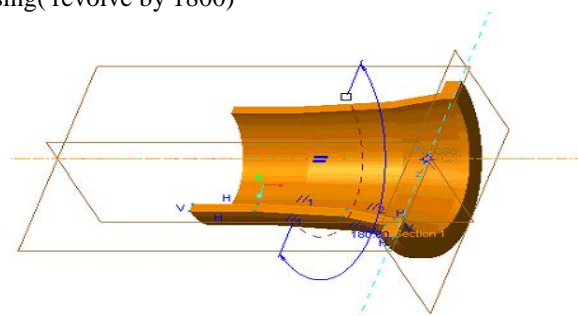

Fig .2: Revolved bottom half



4.1.2 Meshing the model

Geometry: STEAM TURBINE CASING  
 Comments: MESHING THE CASING USING TETRA MESH OF SIZE 15

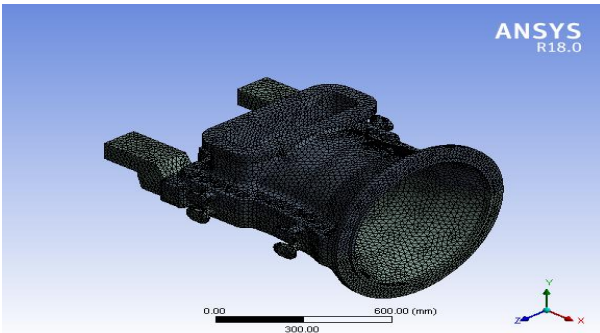

Fig 4.2: MESHING THE CASING

4.1.3 Applying the material conditions and properties:

Here we applying structural steel S235 and condition of steam at different stages as mentioned above. Now we got the solutions of equivalent stress, elastic strain, total deformation and mode shapes as follows

4.1.4. Equivalent Stress

Geometry: STEAM TURBINE CASING  
 Comments: VON-MISES STRESS DISTRIBUTION AT DIFFERENT POINTS ARE SHOWN IN THE BELOW FIGURE, AND THE MAXIMUM VALUE IS 343.17 MPa

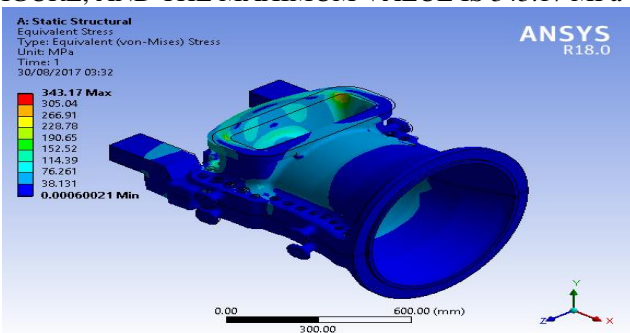

Fig:4.3 Von-mises Stress

4.1.5. Equivalent Elastic Strain

Geometry: STEAM TURBINE CASING  
 Comments: STRAIN DISTRIBUTION AT DIFFERENT POINTS ARE OBTAINED AS FOLLOWS AND ITS MAXIMUM VALUE IS 0.0018325 mm/mm .

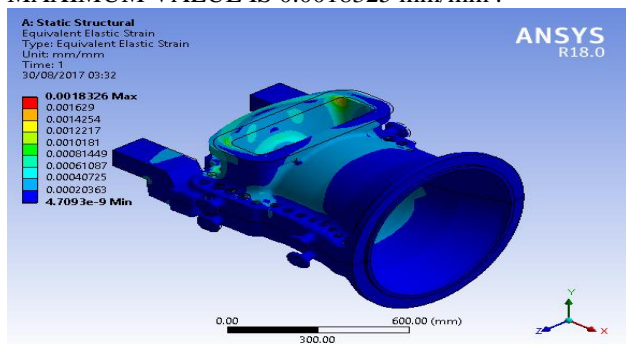

Fig:4.4 Elastic strain

4.1.6. Total Deformation

Geometry: STEAM TURBINE CASING  
 Comments: DEFORMATION AT DIFFERENT POINTS

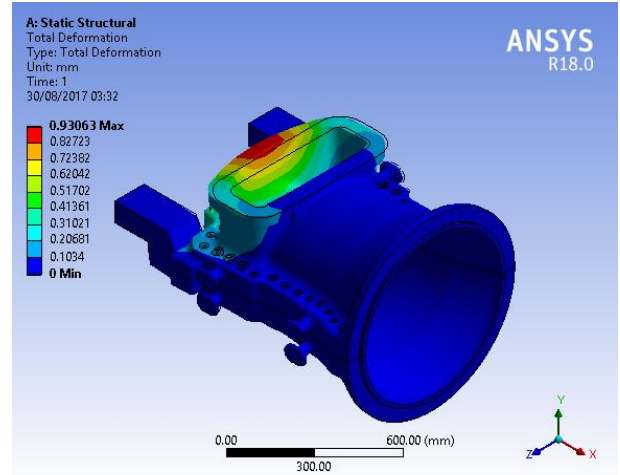

Fig:4.5 Total Deformation

4.1.7. Modal Analysis

Total Of 6 Mode Shapes Have Been Taken But I Shown A Sample Of Mode 1 Only

Mode 1

Geometry: STEAM TURBINE CASING  
 Comments: DEFORMATION AT DIFFERENT POINTS AT MODE 1

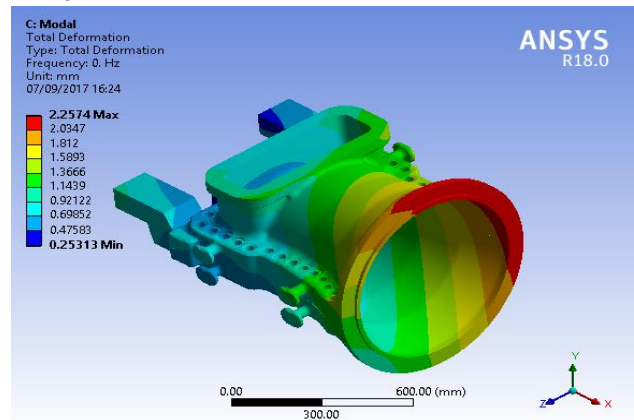

Fig:4.6 Deformation At Different Points At Mode 1

4.2 Static & model analysis on split casing:

now i taken the same casing and spli it into 2 parts with stage 1 as part1 and stages 2&3 as part 2. then applied the properties as follows

Table 4.2 Material Assignment To Parts

S.NO	PART NO	STAGE IT INCLUDES	MATERIAL
1	1	1	structural steel S235
2	2	2&3	structural steel S355

4.2.1 Importing the model

Geometry: STEAM TURBINE CASING  
 Comments: IMPORTED MODEL OF CASING FROM CATIA TO ANSYS R18.0

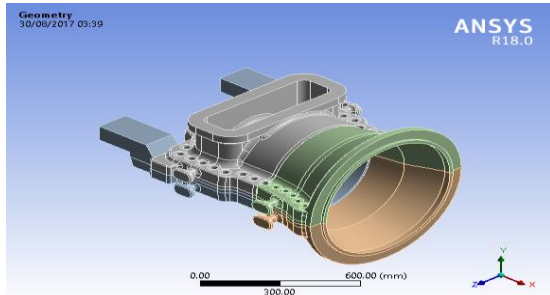

Fig 4.7: Imported Model Of Casing From Catia To Ansys R18.0

4.2.2. Meshing the model

Geometry: STEAM TURBINE CASING

Subject: STRUCTURAL ANALYSIS  
 Comments: MESHING THE CASING USING TETRA MESH OF SIZE 15

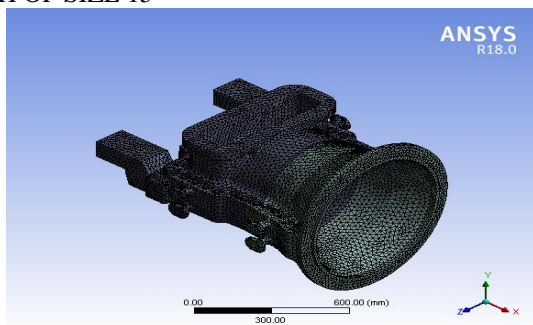

Fig 4.8 :MESHING THE CASING

5.2.3 Applying the material conditions

Here we applying structural steel S235 To the initial stage and structural steel of S355 To the later stages and the steam conditions also applied at different stages as we applied earlier

Now we got the solutions of equivalent stress, elastic strain, total deformation and mode shapes for our split casing as follows

4.2.4. Equivalent Stress

Geometry: STEAM TURBINE CASING

Subject: STRUCTURAL ANALYSIS

Date Wednesday, August 30, 2017

Comments: VON-MISES STRESS DISTRIBUTION AT DIFFERENT POINTS ARE SHOWN IN THE BELOW FIGURE, AND THE MAXIMUM VALUE IS 352.16 MPa

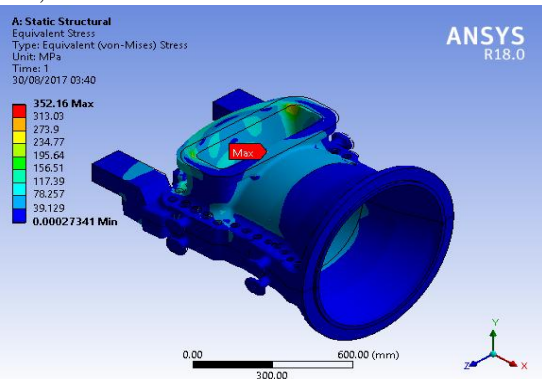

Fig:4.9 Von-mises Stress

4.2.5. Equivalent Elastic Strain

Geometry: STEAM TURBINE CASING

Subject: STRUCTURAL ANALYSIS

Date Wednesday, August 30, 2017

Comments: STRAIN DISTRIBUTION AT DIFFERENT POINTS ARE OBTAINED AS FOLLOWS AND ITS MAXIMUM VALUE IS 0.0019458 mm/mm .

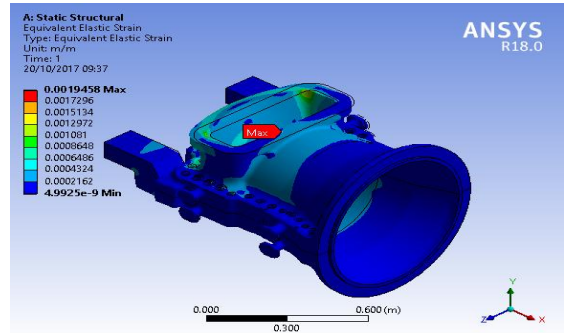

Fig 4.10 : Elastic Strain

4.2.6. Total Deformation

Geometry: STEAM TURBINE CASING

Subject: STRUCTURAL ANALYSIS

Date Wednesday, August 30, 2017

Comments: DEFORMATION AT DIFFERENT POINTS

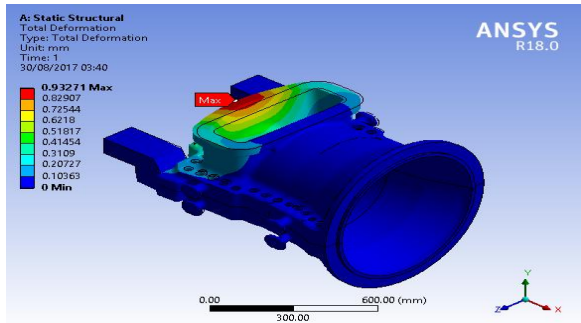

Fig 4.11: Total Deformation

4.2.7. Modal Analysis

Here also a Total Of 6 Mode Shapes Have Been Taken But I Shown A Sample Of Mode 6 Only

Mode 6:

Modal Analysis

Geometry: STEAM TURBINE CASING

Comments: DEFORMATION AT DIFFERENT POINTS AT MODE 6

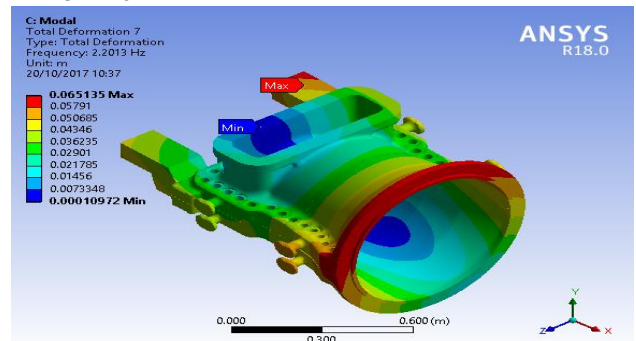

Fig 4.12: Deformation At Different Points At Mode 6

#### 4.4 Results comparison

##### 4.4.1 stress comparison

Stress	Single Casing	Split Casing
Van-mises	343.17	352.16

Table:4.1 Stress Comparison

By comparing the stress( van-mises stress) results we can observe that the stress developed in the split casing is more than the single casing, but the change is only about 2.61% . in general engineering applications we can safely ignore the stress change upto 5%. So the split casing design is safe for the required conditions of steam at different stages of the casing.

##### 4.4.2 Strain comparison

Strain	Single Casing	Split Casing
Elastic	0.0018326	0.0019458

TABLE 4.2 Strain Comparison

The strain developed is also with in the safe limits it again indicating the safe working of split casing.

##### 4.4.3 Deformation Comparison

Deformation	Single Casing	Split Casing
Total	0.93063	0.93271

TABLE.4.3 Deformation Comparison

##### 4.4.4 Mode Shapes Comparison

Total Deformation	Single Casing	Split Casing
Mode 1	2.2574	0.034056
Mode 2	1.5929	0.034056
Mode 3	2.1158	0.034056
Mode 4	2.1543	0.068941
Mode 5	2.0721	0.069286
Mode 6	2.2873	0.065135

TABLE 4.4. MODE SHAPES COMPARIISON

The displacements of the casing during its dynamic conditions are much more less in the split casing than the single casing. In every mode shape it has a low value as compared to the single piece casing.

#### V. CONCLUSION

From the results obtained in the previous chapter we can conclude that the stresses developed in the split type casing materials are with in their safe limits. Even though the stress developed in split casing is more than the single piece casing , the design is still in safe condition as the change is only about 2.6%. We compared not only stress but also the strain, deformation & the mode shapes at its operating speeds. Every time we observe the safe limiting values. From this conclusion we can use split casings which are made of two are more materials at different stages, like a high grade materials at initial stage where the pressure and temperatures are very high and a low grade material at the corresponding later stages, where the casing material doesn't need the same strength as it needed in the initial stages. With this kind of casing the production of the turbine equipment is more economical. So with reference with a above data we can preferably use this kind of split casing to make the equipment more economical.

#### REFERENCES

- [1] Laxminarayan.K,AMME 2014. Design and Analysis of High- pressure Casing of a Steam Turbine.
- [2] ASME., 2012. ASME boiler and pressure vessel code, section 8, division 1, pressure vessels.
- [3] bach, c.,2013. versucheuber die widerstansfahigkibener platen.. berlin,Germany: springer variag.
- [4] choi, w., fleury, E., Song, G. & Hyun, J.-S.,2008. A Life assessment of steam turbine rotor subjected to thermo mechanical loading using inelastic analysis. Engineering material, pp.601-604.
- [5] Holmberg, E.O; Axelson, K;,2013. Analysis of Stresses in circular plates and Rings( With application to rigidly Attached Flat Heads and Flanges). ASME Trans J. Appl.mech,Jan,54(2),pp.13-32.
- [6] Kostyuk, A. &Frolov,V., 1981. In: Steam and Gas Turbines.
- [7] Mckenzie, H.W; White, D.J; Snell, C;, 2012. Design of Steam-Turbine Flanges: A Two-Dimensional Photoelastic Study. Journal of Strain Analysis, Jan, 5(1),pp.1-13.