

IMPROVISED MECHANISM FOR STABILITY OF POWER SYSTEM USING SOLID STATE DEVICE: A REVIEW

Vikram Gulia¹, Chetan Praveer²
¹M. Tech. Electrical Engineering, ²Assistant Professor

A classical multi-machine model can be used to study the stability of a steering system during a period of time during which the dynamic response of the system depends to a large extent on the kinetic energy of the periodic masses. The classic system of nine buses of three machines [1] is the simplest model used in studies of system dynamics and requires small amounts of data. Therefore, these studies can be linked in a relatively short time at the lowest possible cost. Among the various methods to calculate the flow of pregnancy, the Newton Ravenson method is selected to calculate the pregnancy flow study.

I. INTRODUCTION

UPFC is the most versatile of the FACTS devices. It can only perform static static compensatory functions (STATCOM), controlled thyristors (TSC) with commutated thyristors (TCR) and phase regulator angles, but also provides additional flexibility in the reactor mix. Some previous functions [17] the actual power flow it is reactivated by injecting the voltage into the chain with the transmission line. Both the angle and the phase angle of the voltage can be changed independently. It can control the actual power flow and the interaction allows the flow of energy in specific routes, transmission lines and load closer to its thermal limits. It can be used to improve the stability of the transient and small signal of the power system. The UPFC scheme appears in Figure 1.1.

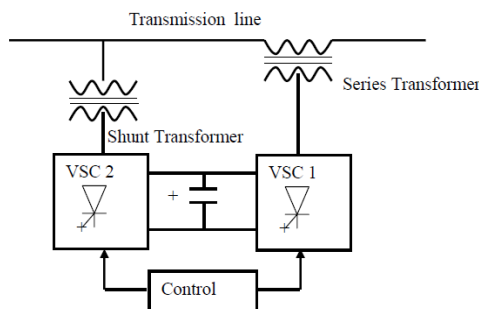

Fig.1.1. Schematic diagram of UPFC

UPFC consists of two branches. The chain branch consists of a voltage source transformer, which injects voltages into a series through an adapter. The inverter is connected to the UPFC input terminal by bypassing the AC supply system and the inverter is connected to the UPFC input terminal in a series with the AC power circuit. Since the UPFC series branch can inject variable voltage and phase angle, it can exchange real energy with the transmission line. However, the UPFC as a whole cannot supply or absorb real energy in a stable state (except for the energy consumed to compensate for losses) unless it has a DC power source.

II. LITERATURE RIVIEW

In recent years, energy, environmental, road and cost problems have delayed the construction of new generation facilities and transmission lines, while demand for electricity has continued to grow. This situation requires a review of traditional energy system concepts and practices to achieve greater operational flexibility and better use of existing energy systems [7-10]. Over the past two decades, significant, if not revolutionary, progress has been made in high-power semiconductor devices and control techniques [28, 29, 34, 35]. These techniques have been essential in the wide application of the transition to inertia systems of the high voltage electric power system and already have a significant impact on AC transmission through the increased use of fixed-frequency VAR controlled by the thyristor (SVC). The fixed VAR processors control only one of three important parameters (voltage, impedance, and phase angle) that determines the power flow in AC power systems: the voltage capacity at the terminals specified for the transmission line. The theoretical considerations and recent studies of the system [1] suggest that the high use of a complex and interconnected AC system that achieves the desired objectives of availability and operational flexibility may also require real-time control of line resistance and phase angle. Hingorani [17] proposed the concept of AC flexible transmission systems or FACTS, which includes the use of high-power electronics, advanced control centers and communication links, to increase the transferability of usable energy to its limits. In the framework of FACTS, and other efforts with similar objectives, the development of a series of thyristor-controlled compensators to control linear impedance, thyristor-controlled tap switches to phase control and other thyristor-controlled devices have already begun dynamic "brakes" and capacitors [3], [4] or are expected to begin in the near future. Although the current VAR and other current thyristor control equipment developed for power flow control (i.e. phase and serial conversion equations) may have the speed needed to control real time, they are very large and custom-designed systems made of large costs, which Requires great installation with important manpower installation [24-29]. For these reasons, they are unlikely to be able to provide an economic solution based on long-term volume production of flexible AC transmission systems. It is long known that the Vair is fixed or advanced, which is the true equivalent of a perfect synchronous condenser, technically feasible [5-8], and with the use of gate closure (GTO). Thyristor [10, 31], economically viable [17]. A recent extension of this approach has been proposed to compensate the controllable series and change the stage [5]. But other FACTs with the therstorization process provide

only limited control [20-26]. Therefore, UPFC is the most versatile FACT device, which can provide different types of control, such as voltage compensation, phase change, real and interactive power compensation. Then, when using UPFC, the transient stability of the power system is improved by placing it on the bus power system. The simplified system design, reduce the size of the equipment and facility workmanship, improve performance and significantly lower the cost of capital, driven by advances in semiconductor power technology.

III. MOTIVATION OF THE PRESENT WORK

Trans-transition stability is an important area of research for several decades. Transient stability returns the system after the fault is removed. Any imbalance between the generation and the pregnancy begins with a transient making synchronous machine rotors "oscillating" because they exert pairs of net acceleration on these rotors. If this net torque is large enough to make some rotors swing enough to one or more of the "sliding pole" machines and lost synchronization. Then the calculation of temporary stability must be necessary. Load flow analysis of the system is required. Temporary stability should be improved to improve system load capacity, as the system can be mounted near its thermal limits. UPFC is a device that provides both string and offset compensation. It also improves the real and interactive capability of the system.

3.1 PROBLEM STATEMENT

An error can cause instability in the system or the device may lose synchronization. A pregnancy flow study should be conducted to analyze the temporal stability of the energy system. If the system cannot continue until the error is cleared, the error can lead to the stability of the entire system. If oscillation in the rotor angle continues around the end position of the increase and the change in angular velocity continues during the temporary increase, the system will never reach its final position. An unbalanced state or transient state can cause instability as the devices fail in the power system. The calculation of the Newton Raafson load flow equation, the rungeekutta method and the discrete method give the spin angle and the initial state. It is necessary to improve the cost and optimize use of the transmission line offset, which can compensate for the voltage, phase change or both, increase voltage and phase change, and improve real and interactive power. Before inserting the static power electronics, constant capacitors, inductors, etc. are used. To make up for control that cannot be done. Then, after the introduction of FACT devices, they give control of compensation. FACT devices such as STATCOM, SVC, etc. They only give compensation derivation. Therefore, a control device that can provide serial and bypass compensation must be used, and its transient stability must be increased so that the load of the transmission line is closer to its thermal limit.

IV. CONTROL STRATEGY OF UPFC

4.1. Control Strategy

The main function of UPFC is to control the flow of real and

reactive power by injection of a voltage in series with the transmission line. The schematic of UPFC is shown in Fig 4.1 .The UPFC consists of two branches .The series branch of the UPFC can inject a voltage with variable magnitude and phase angle, and the shunt branch is required to compensate(from the system) for any real power drawn , supplied by the series branch and the losses.

$$9\Re(\bar{V}^{u1}\bar{I}_1^* + \bar{V}^{u2}\bar{I}_2^*) - P_{loss} = 0 \tag{4.1}$$

It is this context that suitable control strategies and control design to achieve the same ease of importance. The control strategies should have the following attributes:

1. Steady state objective should readily achievable by setting the references of the controllers.
2. Dynamic and transient stability improvements.

The UPFC allows us three "degrees of freedom"

1. Magnitude and angle of series voltage
2. Shunt reactive current.

The real and reactive power flow in the line can be controlled independently using the series injected voltage [29-31]. It should be noted that the UPFC uses Voltage Source Converters (VSCs) for series voltage injection as well as shunt current control. The injection of series voltage can respond almost instantaneously to an order. The shunt current, however, is controlled indirectly by varying the shunt converter voltage (closed loop control of shunt current is required).

4.1.1 Series injected voltage control

To achieve real and reactive power flow control we need to inject series voltage of the appropriate magnitude and angle. The injected voltage can be split into two components which are in phase ("real voltage") and in quadrature ("reactive voltage") with the line current. It is to be noted that the line current measurement is locally available. The real power can be effectively controlled by varying the series reactance of the line. Reactive voltage injection is like series insertion of reactance except that the injected voltage can be

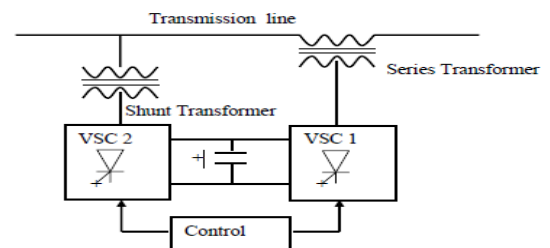

Fig.4.1 Unified Power Flow Controller (UPFC)

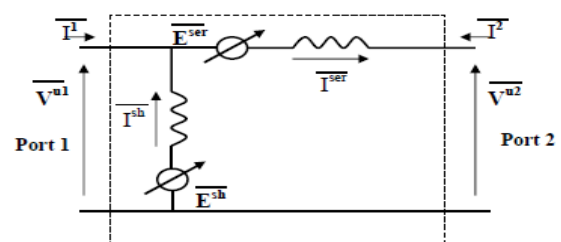

Fig.4.2 UPFC as a two-port device

Independent of the transmission line current. Thus we control active power flow using the reactive voltage. It should be kept in mind that real and reactive power references are obtained from (steady state) power flow requirements. The real power reference can also be modulated to improve damping and transient stability.

In addition, reactive power can be controlled to prevent dynamic over/under voltages. In fact, instead of having closed loop control of reactive power using the voltage, the voltage at port 2 (see Fig.4.2) of the UPFC can be controlled readily by calculating the required real voltage to be injected. We can control reactive power indirectly by changing the voltage reference for port 2.

4.1.2 Shunt current control

It is well known that shunt reactive power injection can be used to control bus voltage. Thus the shunt current is split into real (in phase with bus voltage) and reactive current components. The reference value for the real current is set so that the capacitor voltage is regulated (which implies power balance). The reactive current reference is set by a bus voltage magnitude regulator (for port 1 of the UPFC). The voltage reference of the voltage regulator itself can be varied (slowly) so as to meet steady state reactive power requirements

V. EXPECTED OUTCOME

The classic system of nine buses of three machines is the simplest model used in studies of system dynamics and requires small amounts of data. Therefore, these studies can be linked in a relatively short time at the lowest possible cost. Among the various methods to calculate the flow of pregnancy, the Newton-Ravensson method is selected to calculate the pregnancy flow study.

REFERENCES

- [1] Anderson, P.M., Faud, A.A, Power system control and stability. Golgotha Publication, 1981.
- [2] Concordia, C., "Effect of steam turbine reheat on speed-governor performance." ASME J. Eng.Power, Volume- 81, (1959):pp.201-206.
- [3] Kirchmayer, L.K., Economic Control of Interconnected Systems, Wiley, New York, 1959.
- [4] Young, C.C., and Webler R.M., "A new stability program for predicting the dynamic performance of electric power systems", Proc. Am. Power Conf., Volume-29, (1967): pp.1126-1139.
- [5] Byerly, R.T, Sherman D.E., Stability program data preparation manual. Westinghouse Electric Corp., 1970.
- [6] Crary S.B., Power System Stability, Volume.2, Wiley, New York, 1947.
- [7] Ewart, D.N., Flexible AC transmission systems (FACTS) scoping study, 1990
- [8] Hingorani, N.G.: 'High power electronics and flexible AC transmission system', IEEE Power Eng. Reo., July 1988.
- [9] Maliszewski, R.M., Power flow in highly integrated transmission network, CIGRE, 1990
- [10] Christl,N. Advanced series compensation with variable impedance, EPRI Workshop on FACTS, Cincinnati, Ohio, USA, November 1990.
- [11] Gyugyi, L., "Reactive power generation and control by Thyristors circuits", IEEE Trans. Ind. Appl., (1979).
- [12] Sumi, Y., "New static VAR control using force-commutated inverters", IEEE PES Winter Power Meeting, Volume 38 (1981)
- [13] Gyugyi, L., "Advanced static VAR compensator using @le turn-off thyristors for utility applications", CIGRE, 1990
- [14] Gyugyi, L, "Solid-state control of electric power in AC transmission systems", International symposium on electric energy converters in power systems, Italy, 1989
- [15] Erinmez, LA., "StaticVAR compensators", Working Group38-01. Task Force No. 2 on SVC, CIGRE, 1986
- [16] Wood, P., "Study of improved load tap changing for transformers and phase-angle regulators", EPRI Report EL-6079, Project 2763-1, 1988.
- [17] Hingorani, N.G., "FACTS-flexible AC transmission system", IEE 5th international conference an AC and DC transmission, London.
- [18] Round, S.D., Yu, Q., Norum, L.E., and Undeland, T.M., "Performance of a unified power flow controller using a d-q-control system", IEEE conference on AC and DC transmission, London, Volume- 29,(April - May 1996).
- [19] Liu, J.Y., Song, Y.H., and Foss, A.M.: "Simulation of the PWM UPFC Using EMTP", "IEE conference on AC and DC power transmission", Volume-29, (April - May 1996)
- [20] Lombard, X., and Therond, P.G., "Control of unified power flow controller: comparison of methods on the basis of a detailed numerical model", IEEE UPES Summer Meeting, (July -August 1996)
- [21] Schauder, C., and Mehta, H., "Vector analysis and control of advanced static VAR commentator's", IEEE Proc. C, Volume-37, (1993)
- [22] Gyugyi, L., "A unified power flow control concept far flexible AC transmission system", IEE 5th international conference on AC and DC transmission, (Sept. 1991)
- [23] Gyugyi, L., "The unified power flow controller: a new approach to power transmission control", IEEE Trans., Power Deliver., Volume-10, (1995)
- [24] Maheshwari, A., and Ngo, D.T., "Synthesis pulse width modulated waveforms with selective harmonic elimination", IEEE Tram. PowerElectronicsVolume-8, (1993)
- [25] Makombe, T., An investigation of a unified power flow controller., PhD thesis, UMIST, UK, 1997
- [26] Gyugyin L., Schauder, C.D., Williams, S.L., Rietman, T.R., Torgerson, D.R., Edreis, A., "The Unified Power Controller: Anew approach to Power T transmission Control", IEEE Trans. On Power

- Delivery, Volume.10, No.2, and (April 1995):pp.1085-1097.
- [27] Gyugyi, L., "Unified power flow concept for flexible AC transmission systems", IEEE Proc.-C, Volume-139, No.4, and (July 1992):pp.323-332.
- [28] Posh, D. Mihalic, R. PA pic, I., FACTS equipment for Load Flow in High Voltage Systems, Cigre Symposium, Power Electronics in Power Systems, Tokyo, May 1995.
- [29] Mihalic, R, Zunko, P., Posh, D., Modeling of Unified Power Flow Controller and its impact on power oscillation damping, Cigre Symposium, Power Electronics in Power Systems, Tokyo, May 1995.
- [30] Padiyar, K.R., Power System Dynamics- Stability and Control, John Wiley and Sons (SEA) Pte Ltd, Singapore, 1996.
- [31] Schauder, C., Mehta, H., "Vector Analysis and Control of Advanced Static Var Compensator", IEE Proc.-C, Volume.140, No.4, and (July 1993):pp.299-306.
- [32] Walker, Loren H., "10-MW GTO Converter for Battery Peakin Service", IEEE Trans. on Industry Applications, Volume.26, No.1, (Jan/Feb 1990): pp.63-72.
- [33] Padiyar, K.R., Uma Rao, K., "A Control Scheme for Unified Power Flow Controller to improve Stability of Power System", Paper presented at the 9th National Power Systems Conference, India, Dec. 1996.
- [34] Gyugyi, L., "A Unified Power Flow Control Concept for Flexible AC Transmission Systems," IEE Proceedings-C, Volume-139, No.4, (July 1992).
- [35] Gyugyi, L., "Dynamic Compensation of AC Transmission Lines by Solid-state Synchronous Voltage Sources," IEEE Summer Power Meeting, Volume- 93 July 1993.
- [36] Chama, M., and Angquist, L., "Thyristors-Controlled Series Capacitor Design and Field Tests," EPRI Flexible AC Transmission System (FACTS) Conference, Volume-27, (May 1992):pp.18-20
- [37] Jette, G., "Advanced Series Compensation (ASC) – Main Circuit and Related Components," EPRI Flexible AC Transmission System (FACTS) Conference, Volume-32, (May 1992): pp. 18-20