

DESIGN AND DEVELOPMENT OF HYDRAULIC FIXTURE FOR CRANK SHAFT OIL SEAL RETAINER

Mayur P. Durge¹, Prof Ritesh Banpurkar²
¹Student, ²Professor,

Department of Mechanical Engineering, Abha Gaikwad-Patil College of Engineering, Nagpur

Abstract: The fixture is used for holding work piece and proper positioning for machining operation. The working principle of this system is hydraulic system. We are using machining operation for which it is necessary to clamp the component on the fixture and avoid unwanted vibrations while machining operation being done. In this system high pressurized liquid is used to clamp and unclamp work part. The main work of this system is to control direction of the fluid and also fluid pressure.

I. INTRODUCTION

All manufacturing industries use automatic system to reduce the manufacturing time and resources. We are using hydraulic fixture to automate the clamping. More parts will fit within machine and it uses high pressure liquid to fix parts in proper location with small hydraulic components hence get more productivity. For controlling hydraulic system, it uses actuator. An actuator is used in hydraulic system for moving and controlling system, for example by opening a valve. In simple terms, it is also used for converting signal into mechanical motion. We shall be moving from manual system to hydraulic system without compromising the quality of product and also increase productivity. The main function of this hydraulic fixture is to apply clamping force on the work piece so that it can resist the external unwanted forces generated while machining operations. It allows operators to be consistently more productive with less effort.

II. LITERATURE REVIEW

Sridharakeshava K. B. et. al., has discussed mainly three stages of fixture design, 1) information gathering and analysis, 2) product analysis 3) design of fixture elements.

Shailesh S. Pachbhaiet. al., had discussed about advantages of hydraulic fixture and he also gave solution of this fixture, how to secure work part, reduces distortion from clamping and machining forces.

N. P. Maniaret. al., said about locating and clamping considerations, also shown an example of fixturing alternatives and characteristics for various types of fixtures i.e. Modular fixturing, General fixturing.

Navya K.R. et. al., has discussed about basic concept of hydraulic circuit, hydraulic design.

S.D.V.V.S.B.Reddyet. al. has discussed about data required to design fixture, cutting force calculation and analysis of fixture body to check whether the fixture can resist the maximum cutting force during machining.

III. PROPOSED DESIGN

We design to fix a job to their position by using hydraulic

system and this system start from pumping the fluid from hydraulic tank through the filter. Through filter fluid enter into the control valve and AC induction motor operates the pump. The piston movement is controlled by three piston chance over valve to extent the cylinder that is to lift the weight.

The bottom port of the system is connected to pressure line and top port is connected to the hydraulic tank and piston move upward the rise load and fluid other side of the piston is release to the hydraulic tank through the top port and the control valve. After that the top port is connected to the pressure line and bottom port is connected to the hydraulic tank and piston move down and the weight is lower when the valve is set to the off position and fluid is lock inside the cylinder thereby holding the weight in steady position. Then pump fluid is diverted into the tank without entering the cylinder. The schematic diagram of the system is shown below:

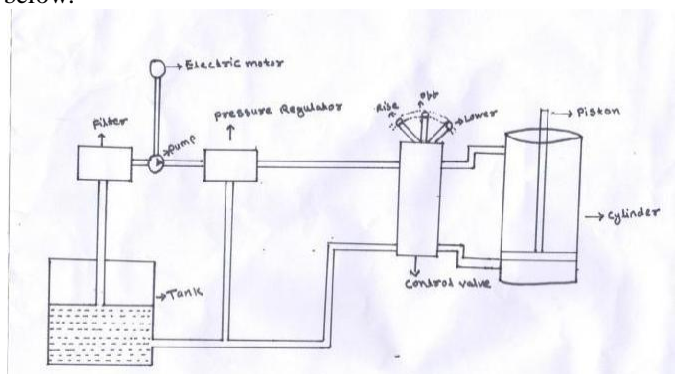

Schematic sketch of the proposed hydraulic system for fixture

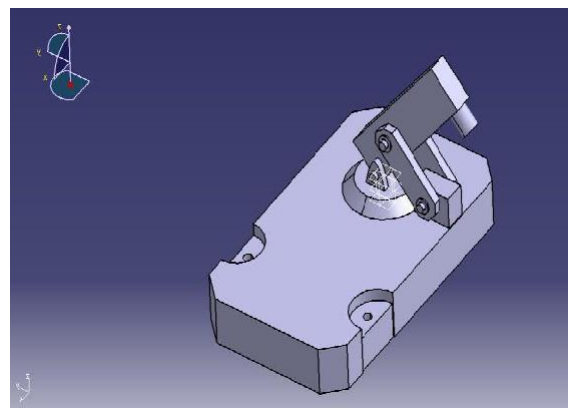

Material Selection

Generally two type of material used for hydraulic power pack.

Cast Iron	Mild Steel
Brittle	Toughness
Low Melting Point	Malleable
Cast ability	Ductile
Machinability	Good Tensile Strength

Technology IJSEAT, Vol 2, Issue 7, July - 2014
ISSN 2321-6905..

Mild steel cheap and easy to form that's why we use mild steel material.

Material type- MS C36.

Fluid Selection

We use Hydraulic Oil HLP C68 because; It is best hydraulic oil with anti-wear properties and high load capacity.

This liquid has good oxidation resistance and excellent at high temperature.

IV. CONCLUSION

We shall be using hydraulic fixture for avoiding manual clamping. It reduces the cycle time. Hydraulic system gives accurate clamping of work parts. The hydraulic system gives excellent production methods. The clamping system shall resist huge machining force on work part. By using manual fixture production rate of industries is less that's why using hydraulic fixture. It increases the production rate and reduces the set up time and thereby reducing the overall cycle time.

REFERENCES

- [1] Sridharakeshava K B, Ramesh Babu. K, "An Advanced Treatise on Jigs and Fixture Design" International Journal of Engineering Research & Technology (IJERT) ISSN: 2278-0181 Vol. 2 Issue 8, August - 2013.
- [2] Shailesh S Pachbhai and Laukik P Raut, "Design and development of Hydraulic Fixture for machining Hydraulic lift Housing "International Journal of Mechanical Engineering and Robotic Research ISSN 2278 - 0149 Vol. 3, No. 3, July, 2014.
- [3] N. P. Maniar, D. P. Vakharia, " Design & Development of Fixture for CNC -Reviews, Practices & Future Directions" International Journal of Scientific & Engineering Research Volume 4, Issue 2, February-2013 ISSN 2229-5518.
- [4] Navya K.R., S. Pradeep, "Automation of Fixtures Using Hydraulic Power Pack for A Bogie Underframe" IOSR Journal of Mechanical and Civil Engineering e-ISSN: 2278-1684, p-ISSN: 2320-334X, Volume 10, Issue 1 (Nov. - Dec. 2013).
- [5] S.D.V.V.S.B.Reddy, P. Satish Reddy, V. Subrahmanyam, "Design And Analysis Of Machining (Hydraulic) Fixture for AVTEC Transmission Case Component" International Journal of Science Engineering and Advance