

SOLAR GRASS CUTTER MACHINE

Sachin Prabha¹, Dattatray G.Biradar², Sachin Panshette³, Veerbhadrappa.T⁴
^{1,2,3}M.Tech student, ⁴Assistant Professor
School of Mechanical Engineering, REVA University, Bangalore.

ABSTRACT: In the developing country like India where farming being the backbone of the economy of the country and farmers being the effecting agents of the GDP, care has to be taken for the well being of them. On a case study it was been reviewed that a major portion of the investment for farming today is taken up by the weedicides and pesticides in order to control the grass in the crops. And the other way out being dependent on the manual labourer which usually results with killing of time. These traditional methods have following hurdles.

- Regular increase in the labour charges.
- Scarcity of the weedicides and there increasing fares.
- Not safe for the crops.

Hence to provide a alternate method for the removal of unwanted grass with a efficient monetary technique an idea of solar grass cutter machine is brought forward in this paper. This project is to design and fabricate in order to minimize manual work as well as to use renewable source of energy by using a solar panel and to overcome the above difficulties. Designing and Fabrication of SOLAR GRASS CUTTER has the following merits,

- Pollution free as solar energy is being used.
- More economical, as solar energy is abundantly available.
- Easy to handle and maintain.
- Even can be used on a small scale for gardening.

This process started from the study of the early manufactured grass cutting machines and there designs. The 'Budding mower' manufacture in 1832 and further modified in 1850 using chains to transmit power from the rear roller to the cutting cylinder. It was called 'SilensMessor' meaning silent cutter. In US, Colonel Edwin George produced the first gasoline powered mower in 1919. Electric powered mowers and rotary cutting machines emerged in the 1920's and 1930's. Accordingly a solar panel with battery is used in this project. DC motor for working of the blades. Whereas wheels, handle and metal frame are being used to make the machine user friendly.

Keywords: Journal bearings, Pedestal bearings .

I. INTRODUCTION

Grass cutter machine can easily be found everywhere in hardware shop with reasonable price. The grass cutter machine is required for some private residence in housing area was having landscape in the house. The modern design creates the machine grass cutter which is safer than ever before to be used in private residential. Today, there are many machine grass cutter in the market. But it still can be

improved or redesign especially from ergonomic point of view. It is because some of the characteristics are not suitable for objective use in area industry like blade shape and material of blade, economic factor like currently was use the fuel, movement limited for used electricity, and not flexible. Therefore, this is a new proposal idea of a machine grass cutter where it was applied the ergonomics design concept which is cover the ergonomic aspects like safety, user friendly in term of functional, cost and the specially was used the solar energy was generated by solar panel as a source of power replacement the petrol like currently grass cutter machine at the market. This project will apply the Design for Manufacturing and Assembly (DFMA) methodology. Therefore, one of the DFMA approaches, Lucas Hull DFA are implemented in order to improved the product development process and reduces manufacturing cost. It is because a lot of cost involved in manufacturing and assembly of a product A significant part of this cost can be attributed to the labour intensive activities associated with assembly. Therefore this approach is used in simplifying the product structure, reduce assembly cost and time and to quantify improvements. This report emphasizes more on one type of landscape appliance which is a Solar Grass Cutter.

II. WORKING PRINCIPLE

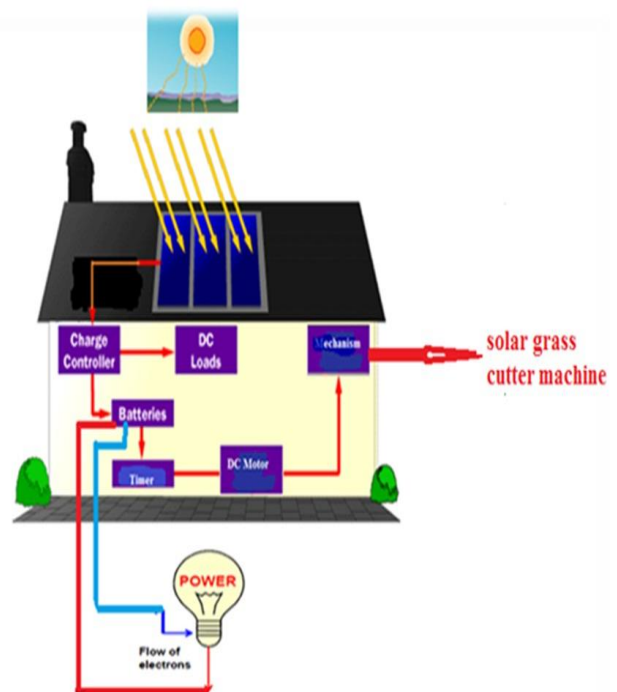

The light rays from the sun falling on the solar panel create a temperature variation in the surface of the panel creating the required environment for the solar energy generation. Due to the presence of photovoltaic cell present in the solar panel the photons are absorbed and stored. The energy absorbed by the solar panel is passed through the cable connections between the solar panel and the battery. The energy stored in the battery is stagnant energy i.e can be stored and used when required. the complete set up is monitored by the timer controlling all the activities according to the prescribed time. Mechanisms consisting for charge controlling is being used in order to keep the battery safe from overcharging in case of sunny days. The output cable from the battery is given as a power for different equipments to be run for different usages as per requirements.

III. ADVANTAGES OF SOLAR GRASS CUTTER.

1. Compact size and portable.
2. To maintain the uniform size of grass
3. Zero emissions.
4. Operating principle is simple.

IV. MATERIAL SPECIFICATION

Materials for Solar grass cutter are selected depending on the following considerations, which can in general be categorized as cost and technically overall performance. Cost includes initial material cost, manufacturing cost and maintenance cost. The key material properties that are pertinent to maintenance cost and overall performance are

- Size of the solar panel.
- Capacity of the battery.
- Speed of the cutters.

4.1 SOLAR PANEL

A solar panel is a set of solar photovoltaic modules electrically connected and mounted on a supporting structure. A photovoltaic module is a packaged, connected assembly of solar cells. Each module is rated by its DC output power under standard test conditions (STC), and typically ranges from 100 to 320 watts. The efficiency of a module determines the area of a module given the same rated output - an 8% efficient 230 watt module will have twice the area of a 16% efficient 230 watt module. Basically every solar panel will generate 12voltage along with variable current in it may be 7.5 amps. But in our project we are using 10 watt power capacity of solar panel. In order to run a mechanism the motor required 12 volt. And Variable current so that we are storing that power in to battery in order to run the mechanism.

Our battery capacity is 12 volt and 7.5 amps.

Hence power is calculated by = Voltage*current
 = 12*7.5
 =90 watt (In a single battery)

In order to store this much of power in battery we required time

Total battery power =Power generation of panel per hour*Time

Hence 90watt. =10*Time
 Time=9 Hour

4.2 DC MOTORS

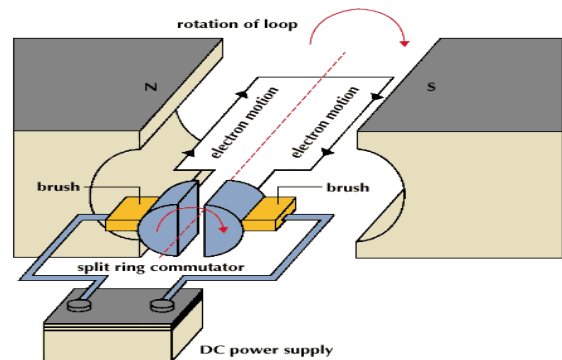

Fig 4.2.1 Working representation of DC motor

The lawnmower isn't the only important aspect of this project. The motor powering the blades under the mower deck is just as crucial. Like the lawnmower there is a choice between two types of motors: internal combustion and electric. The internal combustion engine is the most common but electric motors are slowly gaining popularity. The internal combustion engines for lawnmowers are typically 2-stroke engines ranging between 50cc and 150cc. The drawback for them is that the engine produces vibrations and in order to start the engine a drawstring is typically used, Hence in order to avoid the vibrations electric DC motor has been used in this project. The other type of motor is electric. The electric motors for lawnmowers are typically 12V brushless motors weighing about 15-20 lbs. The benefits of the electric motors are that they run very quietly and they don't take up too much space on the mower chassis. The one drawback to electric motors is the power. Usually the more power needed out of the motor the larger and heavier it gets. Luckily the power needed to turn the blades on a mower doesn't require too much power. Using a brushless motor also adds to the safety of the motor. The brushless doesn't create sparks like the brushed motors do. The motor can also be precisely controlled. Figure 4.2.1 shows an electrical diagram of a simple DC motor.

4.3 BATTERIES:

For the selection of the batteries, we must first calculate out how much power we need in order to run our push mower. The mower is 120v and uses 12Amps, to calculate out how much power we need to run it for one hour; we can use the following equations.

Power (Watt Hours) = Volts * Current (Amp Hours)
 Power= 120V * 12Ah

*Amp Hours = Amps * Hours ran*

Using this we calculate out that we need 1440 watts of power to run the mower for 1 hour. This tells us that we are going to need some serious power and that we may need more than one. There are two main types of batteries functionality wise that we need to consider. There are Starting batteries and then there are Deep cell batteries. For our project, we are not in need of large amounts of current at any one instant because we are not starting any large engines. We will have a DC brushless motor for our mower and a few other power consuming devices. Due to our energy needs, our best choice

of battery would be one or two Deep cell batteries that can provide us with the amount of energy we need for the amount of time needed. Our project will need to be able to run off of the battery for no less than 20 minutes. That is the maximum amount of time allotted to a team to mow the given yard.

4.4 WHEELS

There are two spindle, or free moving, wheels that are going to be used for the front of our design. These wheels are eight inches in diameter and two inches wide. The spindle wheels will be attached to the front of the lawnmower frame by using a three hundred and sixty degree spinning attachment that came attached to the wheels. The two electric motor wheels will be the drive system for the machine. The same process as a zero turn riding lawnmower will be applied to make the turning radius of the machine as minimal as possible. They will be attached to the rear of the lawnmowers frame to get the full effect of the zero turn process. The zero turn lawnmower spins the wheels in opposite directions to turn effectively left or right. These wheels will be attached securely to the frame to insure that they do not come off in the process of turning or moving. The dimensions of the powered wheels are: diameter of 285 mm and a width of 35mm.

4.5 HANDLE



Fig 4.5.1. Handle or Frame.

The size of the handle mainly depends on the size of the lawnmower being manufactured. Use of many light weight polymers can be done in order to make the lawnmower light weight.

4.6 EXTERNAL IRON FRAME WORK

The external frame work is having length of 4 foot and breadth of 1.5 foot there are welded as pillars, which will give the support for the surface of the platform with lever arrangement At the bottom of the platform we have attached a lever .Hence when a pressure is applied on the surface of the platform its support strongly because of the welding.



4.7 ROTARY BLADE

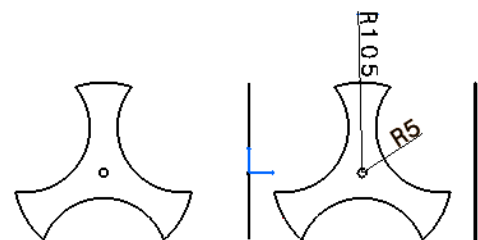

Fig 4.7.1 Design of rotary blade

This machine will also tend to cut lower (13mm) than a standard four-wheeled rotary. The main parts of a rotary mower are Cutter Deck Housing- this houses the blade and the drive system of the mower. It is shaped to effectively eject the grass clippings from the mower. Blade Mounting and Drive System- the blade of a rotary m A rotary mower (viewed from underneath), with a mulching blade that rotates around the center. Rotary mowers a rotary mower rotates about a vertical axis with the blade spinning at high speed relying on impact to cut the grass.

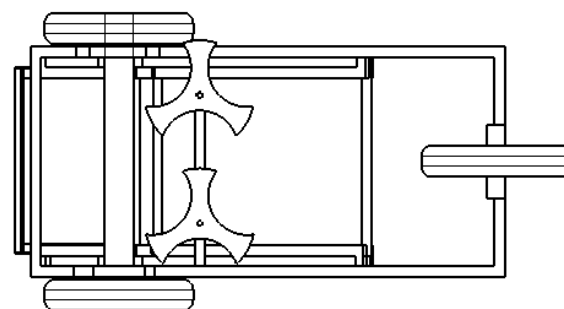

Fig 4.7.2 Bottom view of the machine.

This tends to result in a rougher cut and bruises and shreds the grass leaf resulting in discoloration of the leaf ends as the shredded portion dies. This is particularly prevalent if the blades become clogged or blunt. Most rotary mowers need to be set a little higher than cylinder equivalents to avoid scalping and gouging of slightly uneven lawns, although some modern rotaries are fitted with a rear roller to provide a more formal striped cut.

4.8 BEARING:

A bearing is machine part, which support a moving element and confines its motion. The supporting member is usually designated as bearing and the supporting member may be

journal. Since there is a relative motion between the bearing and the moving element, a certain amount of power must be absorbed in overcoming friction, and if the surface actually touches, there will be a rapid wear. Journal and pedestal bearings are been used in this project based on the requirement of the part.

V. WORKING PRINCIPLE OF SOLAR GRASS CUTTER MACHINE

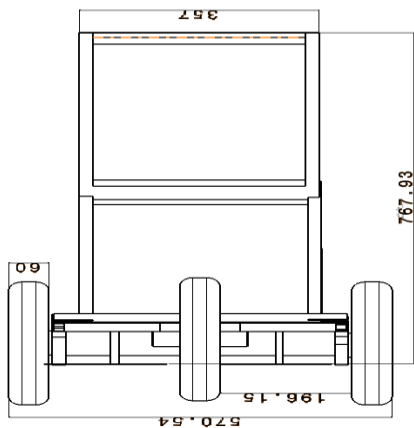

Fig 5.1 FRONT VIEW

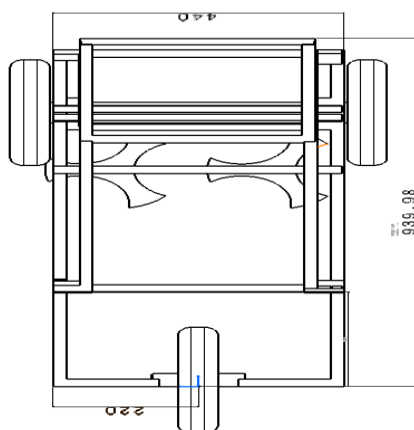

Fig 5.2 TOP VIEW

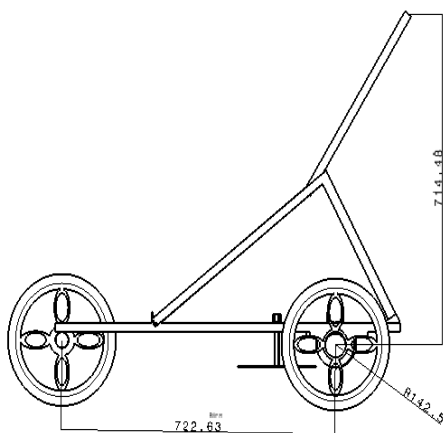

Fig 5.3 SIDE VIEW

Electrical energy of the battery is converted to mechanical energy through a set of blades designed to achieve cutting

operation. The electric circuit ensures power transfer from the battery to run the D.C. motor, whilst the solar panel power to continuously recharge the battery while in operation. The cutting blades tap power from the D.C. motor. When the power switch is on, the electrical energy from the battery powers the motor which in turn actuates the blades. The solar panel generates current to recharge the battery, thereby compensating for the battery discharge. The rotating blades continuously cut the grass as the mower is propelled forward and the cut grass. Height of cut is adjusted by means of the link mechanism via the lift rod. Existing engine trimmers suffers from high levels of engine noise. Average noise level during operation with nylon thread was found 78dB with the available engine silencer. An additional muffler was designed in this study to absorb output noise conveniently by creating a small back pressure without appreciable reduction in output power. A noise level of 5 -7 dB was reduced with added muffler unit. A noise level of Smart lawnmower is 2dB was reduced by using DC motor. A method is first proposed to determine three kinds of mowing paths in minimum time, minimum energy, and mixed operation to achieve the best efficiency. The minimal time mode means that the time consumed for cutting the whole lawn is minimal. The minimal energy mode means that the whole energy consumed during the period of mowing is minimal. The mixed mowing mode simultaneously considers time saving and energy consumption for lawn mowing to achieve a best compromise between two modes.

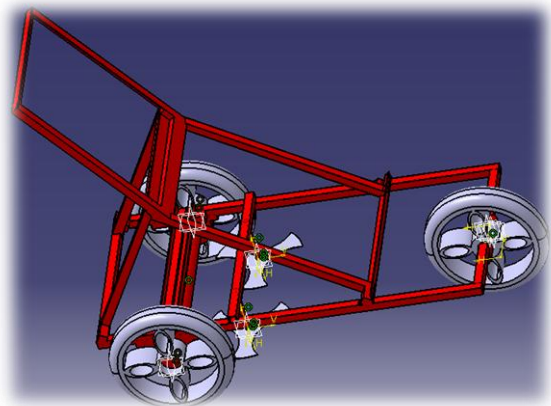

Fig 5.4 Final frame in CATIA

VI. CONCLUSION

Thus this is a promising technology to provide efficient solution to power crisis to affordable extent. This will be the most acceptable means of providing power to the places that involves difficulties of transmission. Moreover walking across a power producing platform then will be a fun for idle people who can improve their health by exercising in such platforms with earning. The electrical energy generated at such farms will be useful for nearby applications. This technology would facilitate the future creation of new urban landscapes, athletic fields with a spectator area, music halls, theaters, nightclubs and a large gathering space for rallies, demonstrations and celebrations, railway stations, bus stands,

subways, airports etc. like capable of harnessing human locomotion for electricity generation.

Future Scope

The major future scopes of this project are as follows.

- It can be used for agriculture purpose where there is a shortage of electricity.
- It is also used for cleaning shop floor by fixing brush instead of rotary blade.
- It is also used for water spraying purpose in garden.
- In future it can be work automatically by the help of sensor camera & remote system.
- It is also used for insecticide by fixing nozzle.
- In future the grass collector is to be mounted

ACKNOWLEDGEMENT

I express my all concepts of gratitude to my professor Shivasharanayya Swamy, Professor, school of Mechanical Engineering, REVA university, Bangalore for guiding and encouraging me throughout the work and also special thanks to all the faculty members of Mechanical Engineering. Credit goes to a great measure to my classmates and friends for their help and encouragement. I would also like to express my gratitude to the authors and publishers of textbooks, magazines, journals and websites from where I have collected the materials and information for this report.

REFERENCES

- [1] Imran Ahmed, Hong Wong, and Vikram Sapila. (2004,July). Internet-Based Remote Control using a Microcontroller and an Embedded Ethernet. Proceeding of the 2004 American Control conference,1329-1331. Retrieved on May 6, 2009 from IEE Explore
- [2] Yan-Fang Li, Saul Harari, Hong Wong, and Vikram Kapila (2004, July). Matlab- Based Graphical User Interface Development for Basic Stamp 2 Microcontroller Projects. Proceeding of the 2004 American Control conference,3233-3236. Retrieved on May 6, 2009 from IEEEExplore
- [3] Chia-Chang Tong (April 2005). The Development of Portable Infrared Color Sensor. 2-3. Retrieved on May 6, 2009 from IEEEExplore
- [4] M. B. Grier (September 2005). Infrared Color Translation. Proceedings of the Ire. 4 (3). 1574-1575. Retrieved on May 6, 2009 from IEEEExplore
- [5] Anshuman Panda, Hong Wong, Vikram Kapila, and Sang-Hoon Lee (December 2005).Matlab Data Acquisition and Control Toolbox for Basic Stamp Microcontrollers. Proceedings of the 45th IEEE Conference on Decision & Control. 3918-3925. Retrieved on May 6, 2009 from IEEEExplore
- [6] Yutaka Hiroi and Akinori Ito (June 2008). Are Bigger Robots Scary? The Relationship Between Robot Size and Psychological Threat. International Conference on Advanced Intelligent Mechatronics. 546-550. Retrieved on May 6, 2009 from IEEEExplore
- [7] R.Ramaprabha and B.L.Mathur (June 2008).Modelling and Simulation of Solar PV Array under Partial Shaded Conditions. ICSET 2008. 7-11. Retrieved on May 6, 2009 from IEEEExplore
- [8] Sung Jun Oh, Dong JOOn Ahn. and Ernest L. Hall (September 1989). A Wide Angle Vision System for Mobile Robot. Center for Robotics Research . 490-497. Retrieved on May 6, 2009 from IEEEExplore
- [9] Jason Smith, Scott Campbell, Jade Morton (July 2005). Design and Implementation of a Control Algorithm For an Autonomous Lawnmower. Department of Electrical and Computer Engineering Miami University. 456-459. Retrieved on May 6, 2009 from IEEEExplore
- [10] Haydar Sahin and Levent Guvenc (April 2007). Household Robotics Autonomous Devices for Vacuuming and Lawn Mowing. IEEE Control Systems Magazine. 20-24. Retrieved on May 6, 2009 from IEEEExplore
- [11] Taj Mohammad Baloch and Timothy Thien Ching Kae (July 2008). Design and Modelling a Prototype of a Robotic Lawn Mower. Electrical and Electronic Engineering Department Universiti Teknologi PETRONAS. 1-5. Retrieved on May 6, 2009 from IEEEExplore
- [12] Bing-Min Shiu and Chun-Liang Lin (March 2008). Design of an Autonomous Lawn Mower with Optimal Route Planning. Department of Electrical Engineering, National Chung Hsing University, Taichung, Taiwan. 1-6. Retrieved on May 6, 2009 from IEEEExplore