

# POWER LINE COMMUNICATION THROUGH MODIFIED OFDM TECHNIQUE

Deepak Mathur<sup>1</sup>, Sumit Sangwan<sup>2</sup>

<sup>1</sup>Master of Technology, <sup>2</sup>Associate Prof.,

ECE Dept. Ganga Institute of Technology and Management, Village Kablana, Jhajjar-124104

**Abstract:** With the advent of new communication technology there are so many development has taken place. Further the media from which the communication data send is so important and the technique used is also very essential part of the technical growth in the line of communication. This thesis introduces a power line communication and the technique used for it. It is media line device and the emerging concept for communication channel and which can be establish easily and use as an existing wire of electricity. It is very interesting approach in establishing last mile broadband access in rural areas. PLC already provides a medium for broadband internet connectivity as well as monitoring control functions for both industries and homes. In general, PLC network is the most expensive network in the world reaching every room. However, it provides an available channel which is hostile when used for communication purposes. This hostility is due to the many problematic characteristics of the PLC from a communications perspective. They include reflections due to impedance mismatch and multipath due to cable joints as well as the different types of noise inherent in the channel. This concept put interest by the impact of impulse noise on the performance of OFDM based PLC system. This thesis presents a design of the PLC model, which is composed of communication model, model of power line and noise model through MATLAB simulation is creating simulative model to evaluate the parameter. For OFDM system, power-lines are modelled like a multipath channel. Noise model is modelled as white noise in addition to the impulsive noise, the mathematics behind the impulse is utilized in an attempt to fully characterize the impulsive noise. The impedance mismatching is considered and, with the channel model, are estimated at the receiver. Different schemes were simulated to compare the bit error rate (BER) for different impulsive noise parameters. Further results indicate that the proposed approach enhances the transmission throughput provides better performance. For impulsive noise, and increases the efficiency of the PLC system as a whole.

**Key words:** power line communication, OFDM, impulsive noise, CAZAC, Zimmer model, Channel and impedance estimation

## I. INTRODUCTION

Most of us have a wireless network in our homes to enable us to enjoy unfettered access to the internet and share data between two PCs and network peripherals like printers. Most recently, the trend towards connecting home entertainment

devices by using Ethernet ports to connect to TVs, Blu-ray players and gaming devices has increasing in common place. Kaspersky Labs estimates that the current number of UK's homes with a wireless LAN installed is around 57 per cent. Ofcom estimates that 1.5 millions households (out of a total of approximately 22 million households) have deployed Power Line Technology to connect them. The most interesting aspect regarding PLC is the ability to use existing infrastructure for signal transmission and reducing deployment costs. Until recently, the biggest problem for PLC was low distance coverage and low data rate was eliminated with the introduction of new standards. The PLC is a need to use distribution lines of electricity for the control signals, IP telephony transfer, and remote data acquisition [1], [2], and [3]. It comes up almost simultaneously with electrical power network. This technology becomes more and more important. The PLC technology should be as an alternative to other existing data channels [4]. PLC technologies are mainly classified into two; narrowband and broadband depending on the frequency band of operation. Broadband PLC operate the frequency range between 1MHz to 300 MHz. Narrowband PLC operates in the frequency range between 3 kHz to 500 kHz. PLC networks also form part of local area networking solutions [5],[6]. However, the PLC channel is a hostile environment for use as a communications media. This is primarily because the characteristics of channels are highly varying with frequency, time, loads and topology. The channel is also plagued with different sources of noise which are difficult to effectively describe parametrically. The main types of noise in PLC include background noise, narrowband interference and impulse noise. Also the signal is attenuated as it transfer the channel from transmitter to receiver. This attenuation is mainly dominated by frequency selective fading. The proper choice of modulation techniques, channel estimation techniques, and impedance mismatching correction methods for the PLC channel is a thorny issue [5], [6 [7], [8], [9], [10] and [11]. The biggest threat to PLC performance is noise; and impulsive noise is the most dominant. This noise and its impact on the performance of an OFDM based system is the main focus of this paper.

## II. IMPULSIVE NOISE

Impulsive noise is the most severe form of noise in PLC channels. It is mainly caused by the switching ON/OFF of electrical appliances or faults in the network. It is classified into three main categories [12]:

- 1- Impulsive noise that is synchronous with the mains frequency and is periodic: This type of impulsive noise is cyclostationary and is synchronous with the mains frequency. It is generated by silicon controlled rectifiers in different power supplies.
- 2- Impulsive noise that is periodic but asynchronous with the mains frequency: This category of impulsive noise is generated by periodic impulses whose repetition rates are between 50 to 200 kHz.
- 3- Asynchronous impulsive noise: This kind of impulsive noise is very unpredictable and is the most dominant. It exhibits no regular occurrence and mainly arises from transients that originate from the connection or disconnection of electrical appliances from the power line network. The impulses can last for between some microseconds and a few milliseconds with a random occurrence. The power spectral density for this kind of noise can go as high as 50 dB above the background noise. It is also sometimes referred to as sporadic impulsive noise.

### III. SYSTEM MODEL

For a creating of the complete PLC communication system, there is necessary to create model of channels as well as noise model and a transmitter and a receiver models. The complete PLC model will be created from particular models. There will be possible to create analysis of a concrete power line based on the simulations of this system with various models of lines. The analysis will be possible to judge in term of possibility to using of various combinations of PLC technologies, security transfer, modulations etc. So that there will be obtained to best parameters of data transfer in mentioned systems. It is necessary to create the channel models for the PLC simulation. There are more possibilities of power line model creating. First of them is the power line model as environment with multipath signal propagation. The parameters of this line are obtained from a distribution network topology or based on metering. Second of them is model, which applies chain parameter matrices to describing the relation between input and output voltage and current by two-port network. In design of PLC system, it is necessary to bear in mind the character of transmission medium and interferences which the PLC communication is influenced. It is necessary to find useable guard interval, modulation technique and encryption to ensure of security and fool proof communication with smallest error rate between data source and receiver. The PLC communication system is possible to divide to particular parts for purpose of modelling:

- 1- PLC communication model
- 2- Models of power lines,
- 3- Noise model.

#### 3.1. The PLC communication model

The model of PLC communication is created by a transmitter, receiver and channel block. It serves for a creating of a source and destination of data communication for subsequent simulations of lines model which they are replaced by block of channel. The basic PLC communication model with OFDM system is shown in the Fig.1 The control

block is used only for enabling or disabling some functionalities of the system, like the estimation/equalization schemes, the start block is responsible of generating the random stream of bits and selecting the corresponding mapping in each sub-carrier with respect to the SNRs estimated by the channel estimation block. A stream of symbols is resulting from the mapping; this serial data obtained is converted to parallel and the pilots are added which are necessary to include to the transmission in case of continuous channel estimation. The estimation is important for determination of amplitude and phase of map's constellation each of subcarrier.

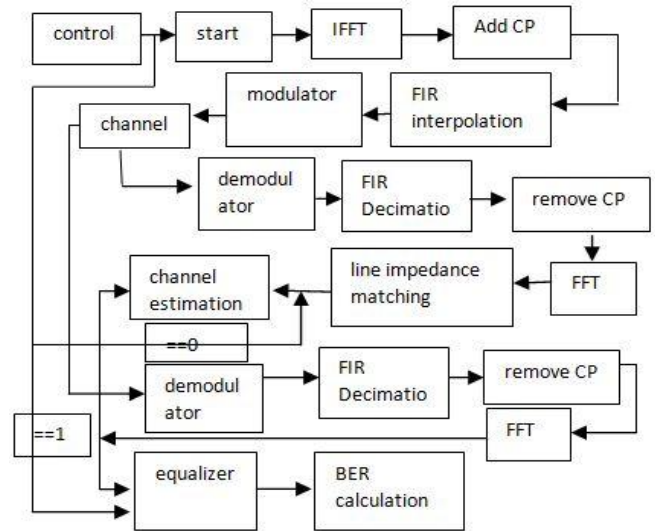

Figure 1: Block diagram of PLC Channel and Impedance estimation model.

The estimation of the channel in an OFDM system requests a inserting of known symbols or a pilot structure to the OFDM signal. The number of parallel streams resulting from the data and pilots should match to the number of carriers. IFFT block transforms data from frequency to time domain. A protect interval is used in OFDM to prevent of ISI (inter symbol interference). A cyclic prefix (CP) is created by a few of last samples of OFDM symbols. CP creates a protect interval between adjacent transferred OFDM symbols in time area. This is a way how to keep orthogonally carries. Again, the parallel streams are converted into serial, and an interpolation filter is used to convert the digital signal into analog to be up converted by the modulator to a certain carrier frequency, here,  $f_c = 46.5$  MHz. After the channel which is considered as a multipath channel in addition to the noise sources added, the receiver's blocks will do the inverse work of the transmitter's blocks. So the demodulator will down-convert the signal into baseband, and the decimation filter is used to digitize the signal. The cyclic prefix is removed and the signal is transformed into frequency domain. The most important blocks here are: the line impedance estimation, the channel estimation, and the equalization & detection blocks. The line impedance estimation block works only in the first channel use, where all the data sent from the transmitter are known at the receiver and used for this estimation. This block is

represented in Fig. 2, it is very simple where we should make a certain division with the known data (Training) and after that an average is done to obtain the impedance estimated on each sub-carrier. These impedances are forward to the channel estimation block and the equalization & detection block for the next channel use.

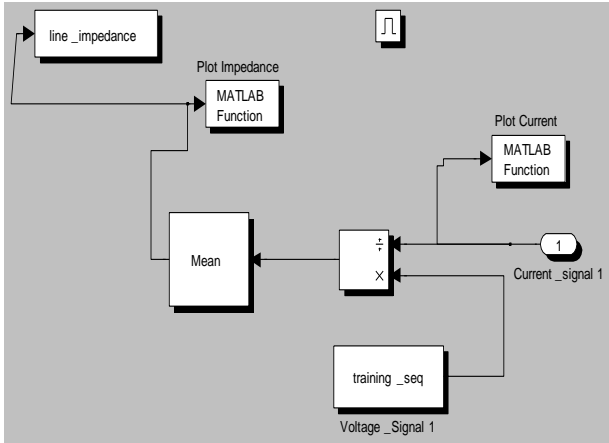

Figure 2: The block diagram of impedance estimation  
 For the second channel use, the impedance estimator will be disabled and the channel estimator block and the equalizer block can work normally starting from this second channel use until the end of the connection. In this time, the signal contains information data and a small training sequence used by the channel estimator represented in Fig. 3.

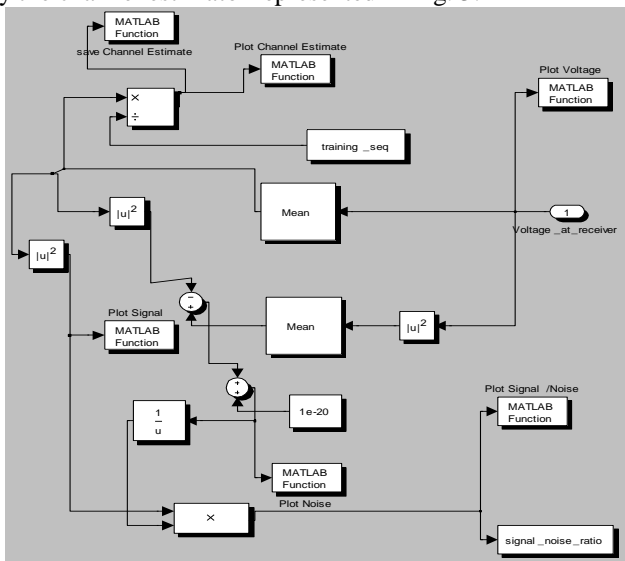

Figure 3: The block diagram of channel estimation  
 The channel estimation block is responsible of estimating the channel taps and estimating the SNR on each sub-carrier. The estimation of the channel taps is done simply by doing a division between the known training sequence and the corresponding received sequence, since we work here in the frequency domain. For the SNRs estimation, we are obligate to work in each sub-carrier trying to separate the noise from the desired signal, and compute the power of desired signal divided by the power of the estimated noise. When we obtain these SNRs, they will be sent back to the transmitter and saved at the receiver for the next use, which choose the

mapping level on each subcarrier in corresponding to the SNRs received and a certain threshold chosen by the method represented by  $S(i)$  in Fig. 4. Since we work in the frequency domain here after the FFT, so the equalizer's work is very simple, it has just to divide the received sequence by the estimated channel (make sure that the estimated channel is in frequency domain). The resulting sequence is than demapping with a different de-mapper on each sub-carrier. Finally the bit stream outputted by the de-mapping is compared with the random bits generated at the transmitter and the BER is calculated.

### 3.2. PLC Channel and Noise Model

Besides simulation of communication system characteristic, it is necessary to identify possible sources of interference and noise because the power line has a significant attenuation of signal and various noises. Therefore the data transfer has a high error rate without any checking algorithm. The fundamental influence on data transmission over power lines are mainly the negative characteristics of power networks. These characteristics can be summarized in:

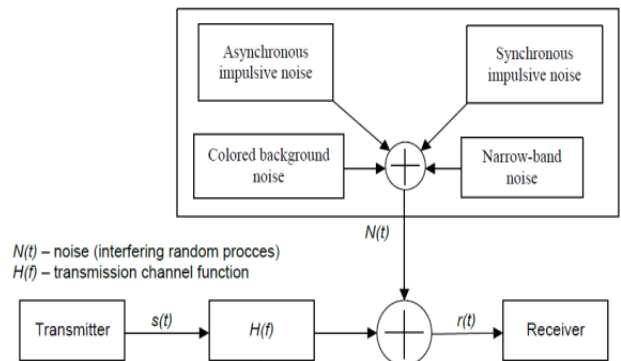

Figure 4: PLC channel model.

- 1- Mismatched impedance
- 2- Attenuation on the communication channel
- 3- Noise and Noise changing in time.

Fig. 5 shows a simplified block model of the PLC channel, which has been made by a Simulink block's help in which it consists of two digital filters. The impulse response and the frequency response of the linear filter is represented in Fig. 6 and Fig. 7

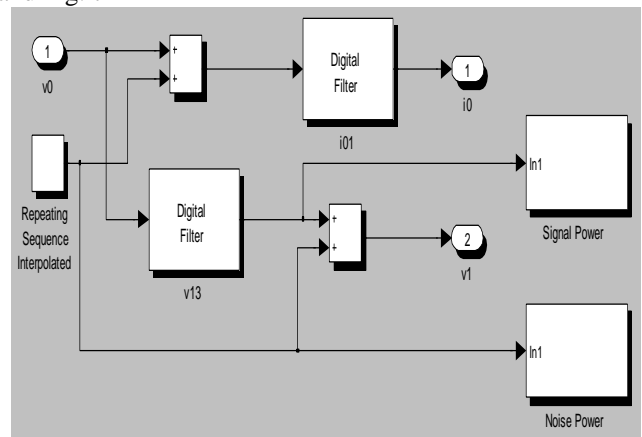

Figure 5: PLC line model with noise measured

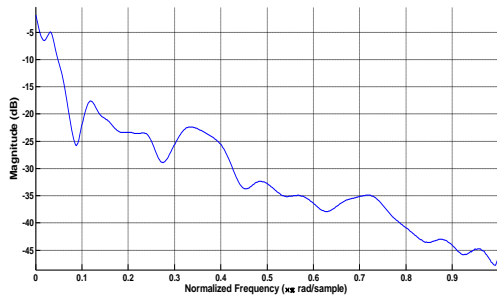

Figure 6: Magnitude Response of Digital Filter

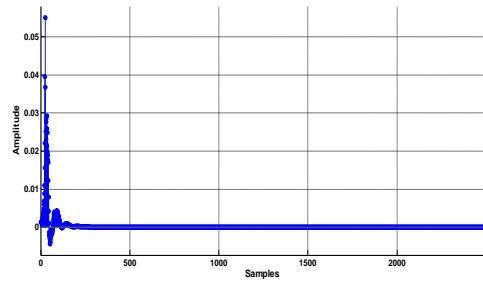

Figure 7: Impulse response of Digital Filter

IV. SIMULATION RESULT

Simulation is done in MATLAB. The simulation parameters are listed in table (1). The input data is randomly generated at the transmitted end. The training sequence i.e. Constant Amplitude Zero Autocorrelation (CAZAC) sequence as shown in fig.9 is used for frame generation which is one type of poly phase codes and has many applications in channel estimation and time synchronization, since it has good periodic correlation properties.

Parameters	Related Values
Frequency band	30 - 88 MHz
OFDM symbol size	N=1024
Cycle Prefix Length	CPL=128
Modulation	1024 QAM
Analog Sampling Frequency	FA_A=830 MHz
Modulation Frequency	Fo=46.5 MHz
Line Impedance	Z=50 Ohms
Guard Band Impedance	$6 * FA_A * N / (FA * filter\_length) = 120$ Ohms
Filter Length	Filter_Length=512

Table 1. Simulation Parameters

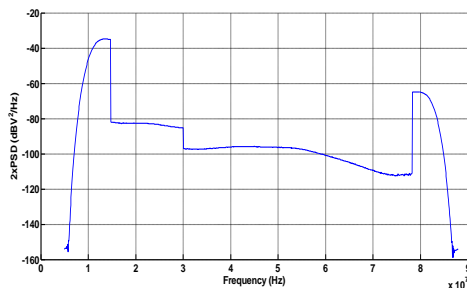

Figure 8: Transmitted signal

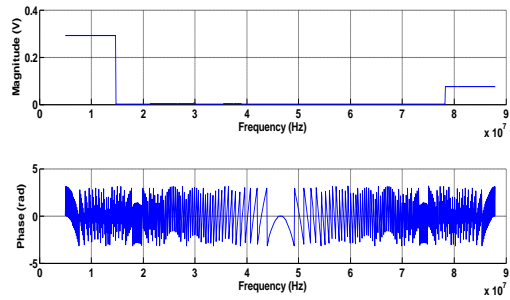

Figure 9: Training sequence

The one possible way to view the effect of Interference is through constellation diagram. Therefore the effect of interference to the symbols is simulated in constellation diagram for QAM.

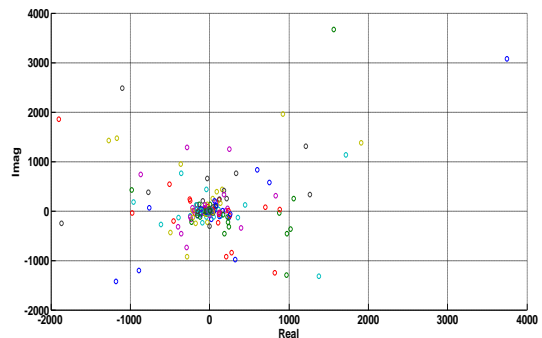

Figure 10: Transmitter Constellation diagram for 1024-QAM

It can be seen that the more the distance of the signal/ noise ratio (SNR) is reduced the more the symbols are dispersed in the constellation diagram.

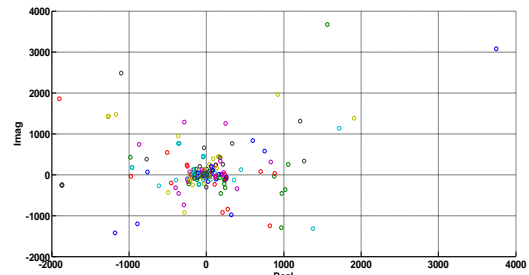

Figure 11: Receiver Constellation diagram for 1024-QAM  
 An interpolation filter is used to convert the digital signal into analog to be up converted by the modulator.

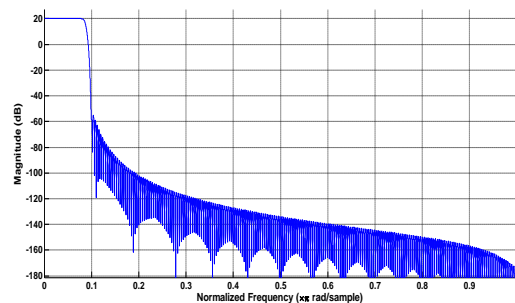

Figure 12: Response of FIR Interpolation Filter

OFDM modulation gives good performance in communication channel with harsh characteristics. So the input coded data is modulated using OFDM modulation technique. The OFDM data is transmitted through the PLC channel which contains periodic impulsive noise. Fig.13 shows the PSD of noise.

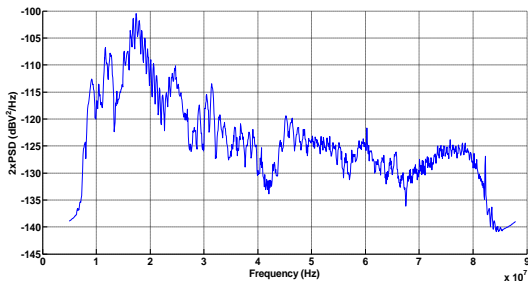

Figure 13: PSD of Noise

The Line impedances which is best suited for Power line communication is estimated and shown in Fig. 14 & 15.

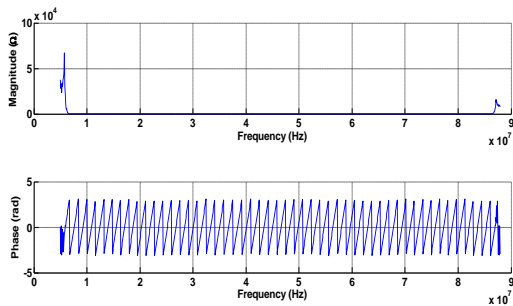

Figure 14: Transmitter Impedance

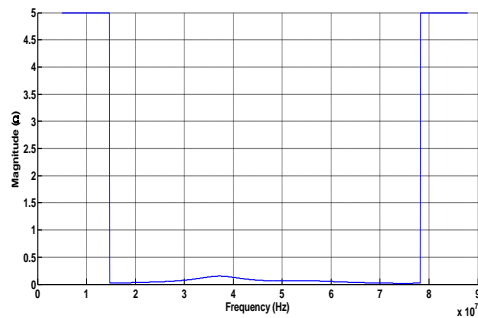

Figure 15: Receiver Impedance

These impedances are forward to the channel estimation block. The Channel estimation is done before FFT, which improves BER performance of the PLC system.

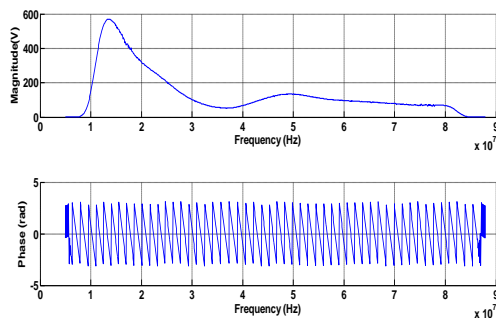

Figure 16: Channel Estimate

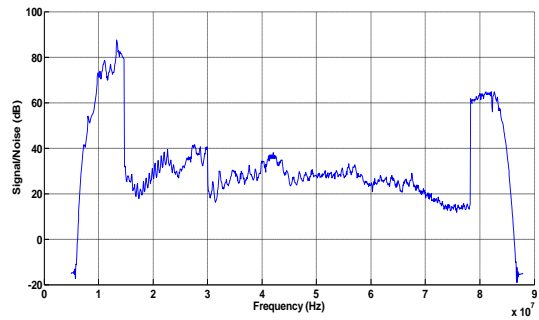

Figure 17: Signal/Noise ratio

To evaluate the proposed system, we calculated the BER of PLC system. Bit Error Rate (BER) of the PLC system increases with increase in noise interfered with the OFDM data.

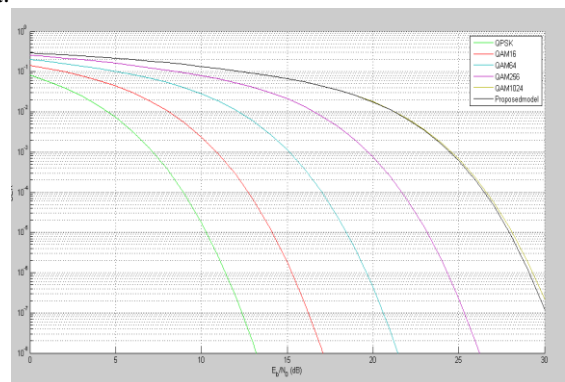

Figure 18: BER dependence on Eb/N0 for particular modulation in OFDM system

The bit error rate (BER) is the percentage of bits that have errors relative to the total number of bits received. Bit error rate reduces as energy per bit is increased. Fig.18 shows the BER of the PLC system with different modulation and Proposed model. The Plot is drawn using BER tool in Matlab under the effect of impulsive noise.

#### 4.1. Simulation Output on PLC Model:

- Bit Error Rate : 0.0017971
- No.of bit error : 317
- Bit Rate : 577685763.8889

## V. CONCLUSION

We deal with design of the PLC communication system model. The model is composed of the OFDM communication model, the model of power lines and noise model. The impedance mismatching is considered and, with the channel model, are estimated at the receiver. Different schemes were simulated to compare the bit error rate (BER) using BER tool. The BER of proposed model is  $10^{-3}$  at 23dB SNR which is very close to 1024 QAM. The simulation model of the PLC- OFDM system correlates well with typical practical systems. The error correction code is not used here. In the future work, we will design a corresponding channel code which will be adaptive and specific to this application. The results of simulations based on the model will be compared with measurements in the future work.

REFERENCES

- [1] P. Mlynek, J. Misurec, M. Koutny, "The communication unit for remote data acquisition via the Internet," in Proceedings of the 7th WSEAS International Conference on Circuits, systems, electronics, control and signal processing (CSES'08). Puerto de La Cruz, Spain: WSEAS Press, 2008.
- [2] R. Achmad, U. Agung, F. Tetsuo, K. Hidehiro, Y. T. Kyaw, U. Yoshiyori, U. Yuki, U. Yosuke, "Wireless LAN and power line communication platform for e-learning multimedia system in underdeveloped area in Lombok island," in 6th WSEAS Int. Conf. on Electronics, Hardware, Wireless and Optical Communications, pages 23–28, 2007.
- [3] C. J. Koinakis, J. K. Sakellaris, "Integration of building envelope and services via control technologies," in Proceedings of the 13th WSEAS international Conference on Systems, Rodos, Greece, July 22 - 24, 2009.
- [4] M. Orgon, "PLC/BPL and Next Generation Networks," in POWERCOM - Conference Communication over MV and LV power lines, Praha, 2007.
- [5] L. T. Berger, A. Schwager, and J. J. Escudero-Garzas, "Power line communications for smart grid applications," Journal of Electrical and Computer Engineering, Vol. 2013, Article 712376, 16 pages, 2013.
- [6] H. C. Ferreira, et al., "Power line communications: An overview," IEEE AFRICON 1996, 558-563, Stellenbosch, September 24-27, 1996.
- [7] F. Zwane, and T. J. Afullo, "An alternative approach in power line communication channel modelling," Progress In Electromagnetics Research C, Vol. 47, 85-93, 2014.
- [8] A. G. Lazaropoulos, "Broadband transmission characteristics of overhead high-voltage power line communication channels," Progress In Electromagnetics Research B, Vol. 36, 373-398, 2012.
- [9] M. Zimmermann, and K. Dostert, "A multipath model for the power line channel," IEEE Transactions on Communications, Vol. 50, No. 4, 553-559, April 2002.
- [10] C. T. Mulangu, T. J. Afullo, and N. M. Ijumba, "Modelling of broadband powerline communication channels," SAIEE, Vol. 102, No. 4, 107-112, December 2011.
- [11] C. T. Mulangu, T. J. Afullo, and N. M. Ijumba, "Estimation of specific attenuation due to scattering points for broadband PLC channels," PIERS Proceedings, Kuala Lumpur, Malaysia, 92-96, March 27-30, 2012.
- [12] M. Zimmermann, and K. Dostert, "Analysis and modelling of impulsive noise in broad-band powerline communications," IEEE Transactions on Electromagnetic Compatibility, Vol. 44, No. 1, 249-258, November 2002.
- [13] M. Zimmermann, and K. Dostert, "Analysis of the broadband noise scenario in powerline networks," Proc. of ISPLC, 131-138, 2000.