

POWER GENERATION USING MAGLEV WINDMILL

Suresh Kumar.G¹, Ganesh Kumar.G.V²

^{1,2}Department of EEE, Velammal Institute of Technology

Abstract: This project dwells on the implementation of an alternate configuration of a wind turbine for power generative purposes. Using the effects of magnetic repulsion, spiral shaped wind turbine blades will be fitted on a rod for stability during rotation and suspended on magnets as a replacement for ball bearings which are normally used on conventional wind turbines. Power will then be generated with an axial flux generator, which incorporates the use of permanent magnets and a set of coils. The selection of magnet materials in the design of wind turbine system will be discussed. A model of wind turbine is built to perform several tests such as starting wind speed, rotational speed at constant wind speed and time taken to stop rotation completely. The results obtained will be compared with the model of conventional wind turbine.

Keywords: Renewable Energy, Wind Energy, Magnetic Levitation, Power Generation, Magnets.

I. INTRODUCTION

Wind is a form of solar energy. It is a natural power source that can be economically used to generate electricity. The way in which wind is created is from the atmosphere of the sun causing areas of uneven heating. In conjunction with the uneven heating of the sun, rotation of the earth and the rockiness of the earth surface winds are formed. The terms wind energy or wind power describes the process by which the wind is used to generate mechanical power or electricity. Wind turbines convert the kinetic energy in the wind into mechanical power. This mechanical power can be used for specific tasks (such as grinding grain or pumping water) or a generator can convert this mechanical power into electricity. The wind turbine is used for the conversion of kinetic energy of wind into electrical energy. The wind turns the blades, which spin a shaft, which connects to a generator and makes electricity. The Maglev wind turbine design is a vast departure from conventional propeller designs. Its main advantages are that it uses frictionless bearings and a magnetic levitation design and it does not need vast spaces as required by the conventional wind turbines. It also requires little if any maintenance. The unique operating principle behind this design is through magnetic levitation. Magnetic levitation is supposedly an extremely efficient system for wind energy. The vertically oriented blades of the wind turbine are suspended in the air replacing any need for ball bearings.

II. WIND POWER TECHNOLOGY

Renewable energy is generally electricity supplied from sources, such as wind power, solar power, geothermal energy, hydropower and various forms of biomass. These sources have been coined renewable due to their

continuous replenishment and availability for use over and over again. The popularity of renewable energy has experienced a significant upsurge in recent times due to the exhaustion of conventional power generation methods and increasing realization of its adverse effects on the environment.

Installed wind power capacity



Source: GWEC

It is estimated that renewable sources might contribute about 20%-50% to energy consumption in the later part of the 21st century. Facts from the World Wind Energy Association estimates that by 2010, 160GW of wind power capacity is expected to be installed world-wide which implies an anticipated net growth rate of more than 21% per year. Maglev wind turbines have several advantages over conventional wind turbines.

2.1 TYPES OF WIND TURBINE

Many types of turbines exist today and their designs are usually inclined towards one of the two categories: horizontal-axis wind turbines (HAWTs) and vertical-axis wind turbines (VAWTs). As the name pertains, each turbine is distinguished by the orientation of their rotor shafts. The former is the more conventional and common type everyone has come to know, while the latter due to its seldom usage and exploitation, is quiet unpopular. The HAWTs usually consist of two or three propeller-like blades attached to a horizontal and mounted on bearings the top of a support tower as seen in Figure.

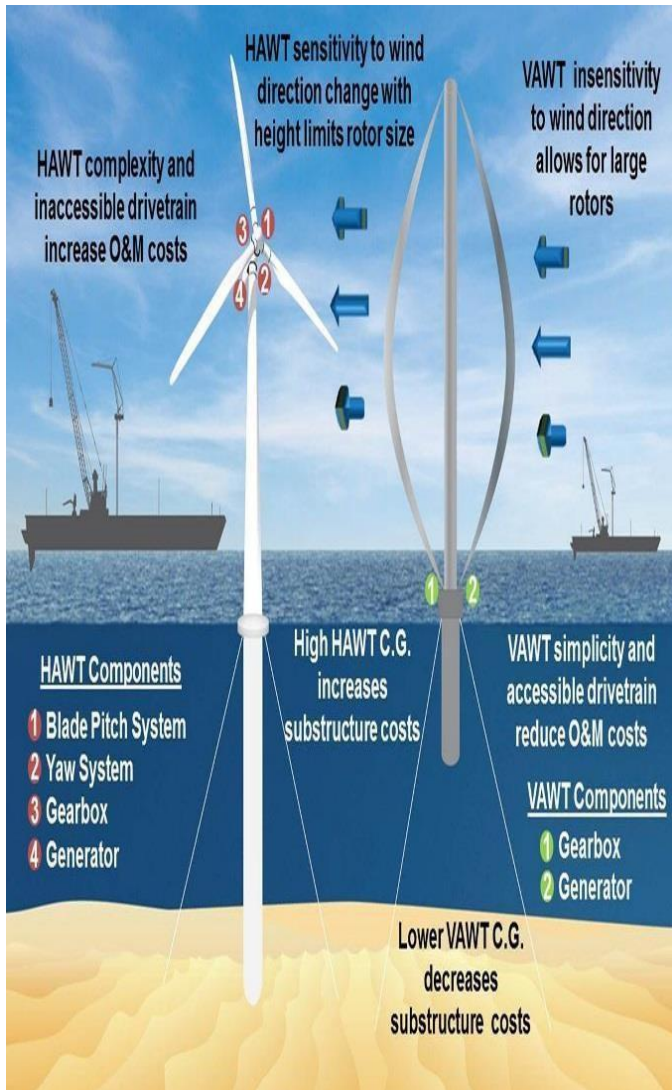

2.2 MAGNETIC LEVITATION

The phenomenon operates on the repulsion characteristics of permanent magnets. This technology has been predominantly utilized in the rail industry in the Far East to provide very fast and reliable transportation on maglev trains and with ongoing research its popularity is increasingly attaining new heights. Using a pair of permanent magnets like neodymium magnets and substantial support magnetic levitation can easily be experienced. By placing these two magnets on top of each other with like polarities facing each other, the magnetic repulsion will be strong enough to keep both magnets at a distance away from each other. The force created as a result of this repulsion can be used for suspension purposes and is strong enough to balance the weight of an object depending on the threshold of the magnets. In this project, we expect to implement this technology from the purpose of achieving vertical orientation with our rotors as well as the axial flux generator.

2.3 OPERATION OF WIND TURBINE

A wind turbine basically draws the kinetic energy from the wind and converts this power to electrical energy by means

of a generator. Its operability is dependent on key components of the turbine and its response to the wind based on how it is built. Figure 2.5 shows an illustration of a conventional wind turbine and its parts. With this turbine, the blades receive the wind and are caused to lift and rotate. Depending on the wind speed the controller will start up or shut off the turbine. If wind speeds are right between 8 to 16 miles per hour, the turbine would start to operate but will shut down if speeds exceed about 55 miles per hour. This is a preventative measure because at very high winds the turbine could be damaged. The anemometer on the turbine calculates this wind speed and sends the information to the controller.

2.4 SELECTION OF MAGNET

Some factors need to be assessed in choosing the permanent magnet selection that would be best to implement the maglev portion of the design. Understanding the characteristics of magnet materials and the different assortment of sizes, shapes and materials is critical. There are four classes of commercialized magnets used today which are based on their material composition each having their own magnetic properties. The four different classes are Alnico, Ceramic, Samarium Cobalt and Neodymium Iron Boron also known Nd-Fe-B. Nd-Fe-B is the most recent addition to this commercial list of materials and at room temperature exhibits the highest properties of all of the magnetic materials. Nd-Fe-B has a very attractive magnetic characteristic, which offers high flux density operation and the ability to resist demagnetization.

III. GENERATOR

The basic understanding of a generator is that it converts mechanical energy to electrical energy. Generators are utilized extensively in various applications and for the most part have similarities that exist between these applications. However the few differences present is what really distinguishes a system operating on motors. With the axial flux generator design, its operability is based on permanent magnet alternators where the concept of magnets and magnetic fields are the dominant factors in this form of generator functioning. These generators have air gap surface perpendicular to the rotating axis and the air gap generates magnetic fluxes parallel to the axis.

IV. POWER GENERATION

When designing a generator it is important to have a firm grasp of the basic laws that govern its performance. In order to induce a voltage in a wire a nearby changing magnetic field must exist. The voltage induced not only depends on the magnitude of the field density but also on the coil area. The relationship between the area and field density is known as flux (Φ). The way in which this flux varies in time depends on the generator design. The axial flux generator uses the changing magnetic flux to produce a voltage. The voltage produced by each coil can be calculated using Faraday's law of induction,

$$V = -N(d\Phi/dt)$$

$$v(t) = L \frac{di}{dt} \quad P = vi = Li \frac{di}{dt}$$

$$W = \int P dt = \int Li \frac{di}{dt} dt = \frac{Li^2}{2}$$

$$W = \int F dt = \frac{1}{2} Li^2 \quad R_m = \frac{l}{\mu_o A}$$

Inductance is given by

$$L = \frac{N^2}{R_m}$$

$$W = \frac{1}{2} Li^2 = \frac{(Ni)^2 \mu_o}{2 \cdot 2X} = \frac{(Ni)^2}{4} \mu_o A (X^{-1})$$

$$F = \frac{dW}{dx} = \frac{(Ni)^2}{4} \mu_o A (X^{-2})$$

$$F = \frac{(Ni)^2}{4X^2} \mu_o^2 A^2 \frac{1}{\mu_o A}$$

Where

$$\phi = \frac{Ni}{R_m} = \frac{Ni}{2X} \mu_o A$$

4.1 INDUCED EMF

In order to explain how an axial flux generator is designed the elements that produce an electromotive force or voltage must be described. An induced EMF is produced by a time varying magnetic field. Michael Faraday performed experiments with steady currents and a simple transformer in hopes of producing a voltage from a magnetic field. He discovered that a constant magnetic field would not induce a voltage but a time varying field could. This was an important discovery in what is known as electromagnetic induction, a discovery that is fundamental in the design of a generator. It is this relative motion of a magnetic field producing a voltage that allows us to be creative in the ways we produce electricity.

4.2 MAGNETIC FLUX

The magnitude of the magnetic flux is greatest when the coil in a magnetic field is perpendicular to the field. In the design of an axial flux generator it is best to keep the coils perpendicular to the field produced by the permanent

magnets. In many conventional motors a winding rotates inside a magnetic field. The number of windings is increased so that each winding is positioned close to 90 degrees to the field. Figure 4.1 illustrates this concept. In our design the angle between the coils and the field does not change, instead the field itself varies with time. Faraday's law of induction states that the induced electromotive force is equal to the change in magnetic flux over the change in time.

$$V = -d\phi/dt$$

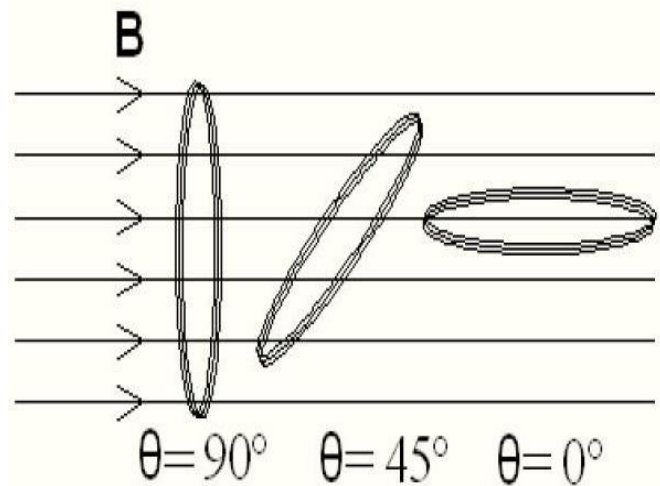

4.3 MAGNET PLACEMENT

Two ring type neodymium (Nd-Fe-B) magnets of grade N52 of outer diameter 28 mm, inner diameter 10 mm and thickness 12.5 mm are placed at the shaft, by which the required levitation between the rotor and the base is obtained. Similar disc type magnets of 30 mm diameter and 4mm thickness are arranged as alternate poles one after the other, along the periphery of the rotor. These magnets are responsible for the useful flux that is going to be utilized by the power generation system.

4.4 BLADE DESIGN

The turbine we used in this prototype is a turbine ventilator. We took a bit of a different approach in our blade design. The base diameter of the blade is 615mm. The top diameter is 480mm. Vortex blades are of industrial grade aluminium. There are 42 blades. Height of the blade hub is 430mm. Base with shaft has a diameter of 610mm. Total height of the shaft is 600mm.

4.5 COIL ARRANGEMENT

28 gauge wires of 1000 turns each are used as coils for power generation. 12 sets of such coils are used in the prototype. These coils are arranged in the periphery of the stator exactly in a line to the arranged disc magnets. The coils are raised to a certain height for maximum utilization of the magnetic flux. Each set of such coils are connected in series aiding to obtain maximum output voltage. The series connections of the coils are preferred over the parallel connection for optimizing a level between the output current and voltage.

4.6 LEVITATION OF ROTOR

In the designed prototype, the base and rotor are separated in the air using the principle of magnetic levitation. The rotor is lifted by a certain centimeters in the air by the magnetic pull forces created by the ring type Neodymium magnets. This is the principal advantage of a maglev windmill from a conventional one. That is, as the rotor is floating in the air due to levitation, mechanical friction is totally eliminated. That makes the rotation possible in very low wind speeds.

4.7 FINAL MODEL

The overall structure of prototype is shown in the figure. Output voltage obtained from the prototype is measured using a multimeter. In the DSO we got a sine wave. A bridge rectifier is used for converting the AC to DC and we got an output of 30V. LED load of 4W is connected to the turbine and current is measured to be 0.25Amps.



V. BLOCK DIAGRAM

Figure displays a system block diagram focusing primarily on the SEPIC circuit that will be implemented in the overall project design. Block by block it can be seen that there is an expected variable wind velocity that will drive the generator. The power input will then be rectified independently from the generator and then filtered to ensure a relatively stable DC voltage supply for the SEPIC circuit. Once the power reaches the input of the SEPIC circuit it is expected to be clean DC with a variable amplitude of 3-5 volts under normal working conditions. The SEPIC circuit will then take the variable input and output a constant 5 volts DC. To ensure that this output voltage stays constant, a pulse width modulator will be implemented as the feedback to constantly sample the output and vary the duty cycle input the transistor gate respectively.

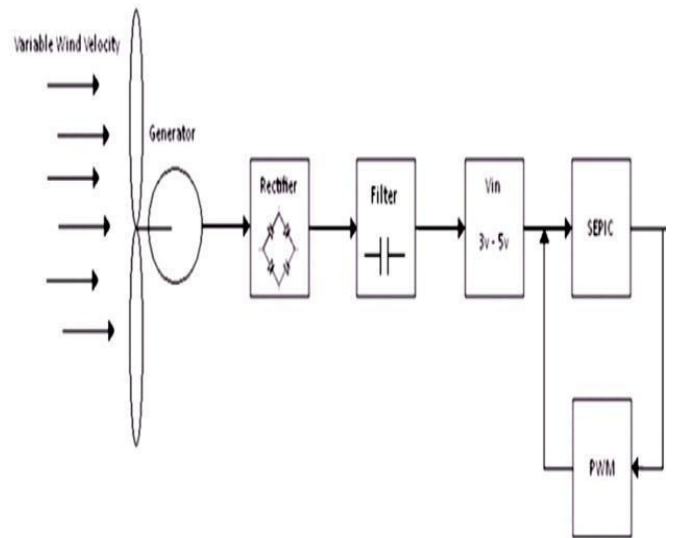

5.1 LIMITATION

In terms of large scale power production, vertical axis wind turbines have not been known to be suitable for these applications. Due to the overall structure and complexity of the vertical axis wind turbine, to scale it up to a size where it could provide the amount of power to satisfy a commercial park or feed into the grid would not be practical. The size of the rotors would have to be immense and would cost too much to make. Aside from the cost, this type of consumer would not desire the area that it would consume and the aesthetics of the product. Horizontal axis wind turbines are good for these applications because they do not take up as much space and are positioned high up where they can obtain higher wind speeds to provide an optimum power output.

5.2 FUTURE DEVELOPMENT

The home for the magnetically levitated vertical axis wind turbine would be in residential areas. Here it can be mounted to a roof and be very efficient and practical. A home owner would be able to extract free clean energy thus experiencing a reduction in their utility cost and also contribute to the "Green Energy" awareness that is increasingly gaining popularity.

VI. CONCLUSION

At the end of the project, the magnetically levitated vertical axis wind turbine was a success. The rotors that were designed harnessed enough air to rotate at low and high wind speeds while keeping the center of mass closer to the base yielding stability. The wind turbine rotor levitated properly using permanent magnets, which allowed for a smooth rotation with negligible friction. Generator satisfied the specifications needed to supply the LED load. An output ranging from 40V to 45V was obtained from the magnetic levitated vertical axis wind turbine prototype. A modified design of savonius model wind turbine blade was used in the construction of the model. An aluminum shaft was used to avoid the Wobbling movement of the rotor. Overall, the

magnetic levitation wind turbine was a successful model.

ACKNOWLEDGEMENT

I thank almighty for bestowing upon us all his blessings for the compilation of this project. I express our sincere thanks to all faculty members of Electrical and Electronics Engineering Department of for their support and encouragement.

REFERENCE

- [1]. Erich Hau "Wind Turbines: Fundamentals, Technologies, Application, Economics" Springer Publishers, 2005
- [2]. "What is Magnetic Levitation?" The Tech FAQ. 29 Apr. 2009 <<http://www.techfaq.com/magnetic-levitation.shtml>>.
- [3]. Dinesh N Nagarkar and Dr. Z. J. Khan, "Wind Power Plant Using Magnetic Levitation Wind Turbine", International-Journal of Engineering and Innovative Technology (IJEIT) Volume 3, Issue1, July 2013.
- [4]. M. A. Mueller and A. S. McDonald, "A light weight low speed permanent magnet electrical generator for direct Drive wind turbines", Institute for Energy Systems, Institute for Energy Systems, Edinburgh University, Edinburgh University, Edinburgh, UK.
- [5]. Liu Shuqin, "Magnetic Suspension and Self-pitch for Vertical -axis Wind Turbines", ISBN:<http://www.intechopen.com/books/fundamental-and-advanced-topics-in-wind-power/magnetic-suspension-and-self-pitch-for-vertical-axis-Wind-turbines>. 2011.