

IMPEDANCE ESTIMATION FOR CHANNEL ESTIMATION THROUGH OFDM METHOD FOR PLC

Vipin Kumar Singh¹, Debprasad Sinha²

¹M.Tech, ECE, ²Assistant Professor(ECE)

Bengal Institute Of Technology & Management, Santiniketan

Abstract: With the approach of latest Communication technologies, there are such an outsized range of enhancements has been placed. Further the channel from that the Communication knowledge sends are thus very important and therefore the technique used is likewise exceptionally a basic part of the specialized development within the line of Communication. This research work can show an influenced line Communication and therefore the strategy used to it. Orthogonal Frequency Division Multiplexing (OFDM) is one key technology most used. So OFDM based system is the fundamental center of this paper. Details of PLC communication model is given in this paper. It's channel line device, and therefore the rising plan for communication which may be engineered up effectively and existing wiring of power. In this research paper we estimate the impedance and channel for broadband PLC. PLC as of currently provides a medium to broadband network and observant management capacities for each business enterprise and houses. The electric resistance mismatching is taken into account and, with the channel model, are calculable at the receiver. Completely different schemes were simulated to check the bit error rate (BER) for various impulsive noise parameters. More results indicate that the projected approach enhances the transmission throughput provides higher performance for impulsive noise, and will increase the efficiency of the PLC system as a whole.

Key words: Power Line Communication, OFDM, impulsive noise, CAZAC, Zimer model, Channel and impedance estimation

I. INTRODUCTION

The majority of us have a wireless network in our homes to empower us to appreciate liberated access to the web and share data between two PCs and network peripherals like printers. Most as of late, the pattern towards using so as to associate home stimulation devices, Ethernet ports to interface with TVs, Blu-beam players and gaming devices has expanded in like manner spot. Kaspersky Labs appraise that the present number of the UK's homes with a wireless LAN introduced is around 57 for every penny. Ofcom gauges that 1.5 million family units (out of an aggregate of roughly 22 million families) have sent Power Line Technology to associate them. The most intriguing angle in regards to PLC is the capacity to utilize existing system for sign transmission and lessening sending costs. Up to this point, the most concerning issue for PLC was low separation scope and low data rate was eliminated with the presentation of the new standard. PLC technologies are mostly characterized into two; narrowband and broadband depending upon the frequency

band of operation. Broadband PLC works the frequency range between 1MHz to 300 MHz. Narrowband PLC works in the frequency range between 3 kHz to 500 kHz. The PLC organizes likewise shape some portion of neighborhood arrangements [Berger 2013] [Ferreira 1996]. Be that as it may, the PLC channel is a threatening domain for use as a Communications channel. This is principally in light of the fact that the attributes of channels are exceedingly changing with frequency, time, burdens and topology. The channel is likewise tormented with various sources of noise which are harder to successfully portray parametrically. The primary sorts of noise in PLC include foundation noise, narrowband impedance and impulsenoise. Likewise the sign is constructed as it exchange the channel from the transmitter to the recipient. This lessening is basically ruled by frequency specific blurring. The best possible decision of tweak strategies, channel estimation networks, and impedance befuddling revision techniques for the PLC channel is a prickly issue [Berger 2013], [Ferreira 1996] [Zwane 2014], [Lazaropoulos 2012], [Zimmermann 2002], [Mulangu 2011] and [Mulangu 2012]. The greatest danger to PLC execution is noise; and impulsivenoise is the most prevailing. This noise and its effect on the execution of aadaptive OFDM based system is the fundamental center of this paper.

1.1 Two-port models

Using the formulae presented, it is possible to derive a two-port model for the line. Consider the circuit in figure 1. It can be made to represent a stub-less transmission line were 0 is the near end and 1 is the far end.



Fig. 1 A two-port network circuit with the indication of the current and voltage signals.

This circuit can be represented by a two-port network, using the hybrid parameters as The hybrid parameters were chosen because they have a simple physical connection. Note that the inverse of the matrix is itself. Considering a frequency dependent attenuation as in the Zimmermann. Considering a frequency dependent attenuation as in the Zimmermann model results in the following model.

$$\begin{pmatrix} v_1 \\ i_0 \end{pmatrix} = \begin{pmatrix} A_v & Z_0 \\ G_1 & A_g \end{pmatrix} \begin{pmatrix} v_0 \\ i_0 \end{pmatrix} \text{-----(1)}$$

$$A_v(t) = \text{sech} \left(l \left(a_1 f^k + \frac{2\pi f}{c} i + a_0 \right) \right) \text{-----(2)}$$

$$Z_0(t) = Z \tanh \left(l \left(a_1 f^k + \frac{2\pi f}{c} i + a_0 \right) \right) \text{-----(3)}$$

$$G_i(t) = \frac{\text{sech} \left(l \left(a_1 f^k + \frac{2\pi f}{c} i + a_0 \right) \right)}{Z} \text{-----(4)}$$

$$A_g(t) = -\text{sech} \left(l \left(a_1 f^k + \frac{2\pi f}{c} i + a_0 \right) \right) \text{-----(5)}$$

1.2 Power Line Communication:

PLC is an economical and practically implementable technology that provides often high speed internet access while consuming less power. It also provides utility applications such as vehicle data communication, advance metering in real time of energy pricing control, peak shaving, monitoring, distributed energy generating, traffic light and street light control and other municipal applications. This technology has been also used for smart grid application.

A PLC system consists of a broadband and narrowband communication. Broadband PLC provides faster internet access and supports small Local area networking [1], while narrowband serves specific applications such as central management of power consumption, remote meter reading, commanding and many more. The primary differences between narrowband (low speed) and broadband (high speed) PLC are bandwidth and carrier frequency. Narrow band PLC uses carrier frequencies lower than 500 KHz, which have higher noise. While the broadband PLC is used in higher frequency, which have lower noises in comparison to lower frequencies. The higher frequency range improves the data rate for transmissions over longer distances. In figure 1.1 it shows the transfer characteristics of the power line channel. In this figure we have shown that high frequency has lower noise. For the purpose of understanding PLC it can be broadly viewed as:

1. Narrowband PLC
2. Broadband PLC

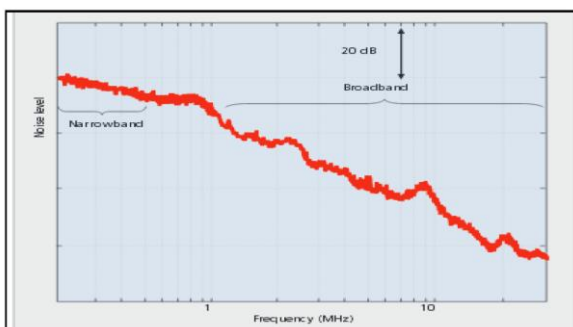

Fig 2- transfer characteristics of the power line channel

II. IMPULSIVE NOISE

Impulsivenoise is the most worsttype of noise in PLC channels. It is basicly brought about by the exchanging ON/OFF of power apparatuses or issues in the network. It is arranged into three principle classifications [Zimmermann 2002]:

- 1-Impulsive noise that is synchronous with the mains

frequency and is occasional: This sort of impulsivenoise is cyclostationary and is synchronous with the mains frequency. It is created by silicon controlled rectifiers in various power supplies.

2-Impulsive noise that is occasional yet offbeat with the mains frequency: This classification of impulsivenoise is created by intermittent driving powers whose redundancy rates are between 50 to 200 kHz.

1.3 PLC Technology

PLC is like other communication technology where a sender modulates sent the data, it injects onto medium, and the receiver de-modulates the data to read. The major difference is that PLC does not need any extra cabling and it re-uses existing wiring. Considering with pervasiveness of power lines. So, the PLC is virtually in all line. The powered devices can be controlled or monitored. When we discuss about the communication technology, it is often useful to refer to the 7-layer of OSI model. Some PLC chips can implement only in the Physical Layer of the OSI model while others integrate in all seven layers. One could use as a Digital Signal Processor (DSP) with a pure software realization of MAC, PHY circuit or an optimized System-on-Chip (SoC) solution, which includes the complete PLC like MAC and PHY. The Cypress CY8CPLCXX series is an example of the latter with a ready-to-use Physical and Network layer and a user-programmable application layer. Before moving to the applications of PLC we let's first understand the various aspects of the Physical layer by viewing it as three segments on the basis of data rate.

III. NETWORK MODEL

For making of the complete Power Line Communication system, there is important to make a model of channels and in addition noise model and a transmitter and a collector model. The complete PLC model will be made for specific models. There will be possible to make examination of a solid powerline taking into account the reproductions of this system with different models of lines. The examination will be possible to judge in term of probability to utilizing of different mixes of PLC technologies, securities exchange, tweaks and so on. So that there will be gotten to best parameters of data move in specified systems. It is important to make the channel models for the PLC simulation. There are more potential outcomes of powerline model making. In the first place of them is the powerline model as environment with multipath signal engendering. The parameters of this line are gotten from an appropriation network topology or taking into account metering. Second of them is model, which applies anchor parameter lattices to portraying the connection in the middle of data and yield voltage and current by two-port network.

In configuration of PLC system, it is important to manage personality a main priority the character of transmission medium and impedances which the PLC Communication is affected. It is important to discover useable gatekeeper interim, tweak procedure and encryption to guarantee of security and bonehead evidence Communication with littlest error rate

	Low Data Rate	Medium Data Rate	High Data Rate
Data Rate	0 - 10 k b p s	10 kbps	>1 Mbps
Modulation	BPSK,FSK,SPSK,QAM	PSK+OFDM	PSK+OFDM
Standard	IEC 61334, ANSI/EIA	PrimeG1, P1901.2	IEEE 1901
Frequency Range	Upto 50 KHz	Upto 500 KHz	1 to 100 MHz
Application	Control and Command	Control and Command	Industrial networking

Table 1.1 PLC technology classification on the basis of data rate

between data source and recipient. The PLC Communications system is possible to partition to specific parts for impulse behind displaying:

- 1-PLC Communication model
- 2-Models of powerlines,
- 3-Noise model.

A. The Proposed PLC communication model

The model of PLC Communication is made by a transmitter, recipient and channel block. It serves for a making of a source and destination of data Communication for consequent simulations of the line model which they are replaced by a block by channel. The basic PLC Communication model with OFDM system is appeared in the Fig.1

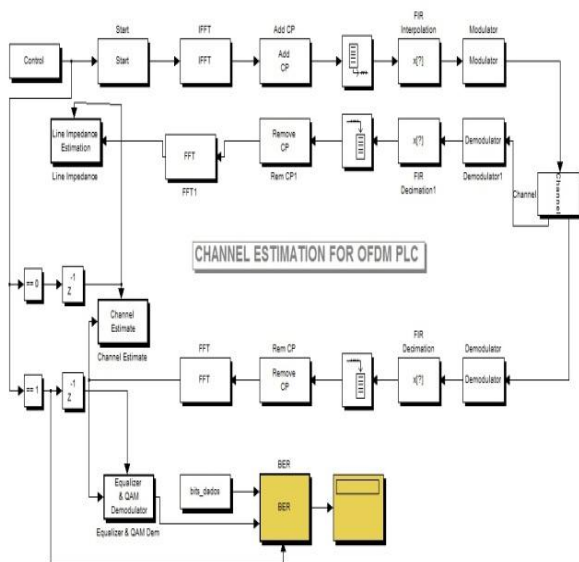

Figure 3: The Proposed OFDM based PLC network.

The control block is utilized just to enable or incapacitating a few functionalities of the system, similar to the estimation/evening out plan, the begin block is capable of creating the arbitrary stream of bits and selecting the corresponding mapping in every sub-transporter concerning the SNRs evaluated by the channel estimation block. No error redressing code is utilized which as a part of expansion

to an interleave can enhance the exhibitions introduced underneath.

A lot of images is coming because of the mapping; this serial data got is changed over to parallel and the pilots are added which are important to include to the transmission in the event of persistent channel estimation. The estimation of the divert in an OFDM system asks for an embeddings of known images or a pilot structure to the OFDM signal.

The quantity of parallel streams coming about because of the data and pilots ought to match to the quantity of transporters. IFFT block changes data from frequency to time area. A secure interim is utilized as a part of OFDM to forestall of ISI (bury image obstruction). A cyclic prefix (CP) is made by a couple of the last specimens of OFDM images. CP makes an ensure interim between adjoining moved OFDM images in the time range. This is a path how to keep orthogonally conveys. Once more, the parallel streams are changed over into serial, and an insertion channel is utilized to change over the advanced sign into simple to be unconverted by the modulator to a specific transporter frequency, here, $f_c = 46.5$ MHz

Figure 2 shows the power spectral density of the transmitted signals. The variety in the powerspectral exhibited in Fig.2 is because of the diverse spectral of mapping, so distinctive powerspectral, utilized as a part of the transmitted sign.

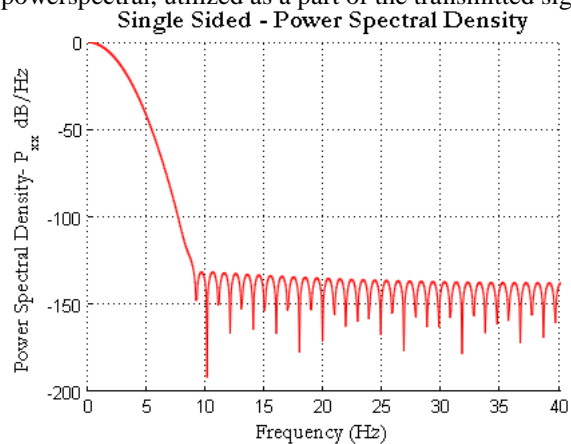

Figure 4: Generating Basic Signals

After the channel which is considered as a multipath divert notwithstanding the noise sources included, the beneficiary's blocks will do the backwards work of the transmitter's blocks. So the demodulator will down-proselyte the sign into baseband, and the obliteration channel is utilized to digitize the sign. The cyclic prefix is evacuated and the sign is changed infrequency space. The most basic blocks here are: the line impedance estimation, the channel estimation, and the adjustment and recognition blocks.

The line impedance estimation block works just in the main channel use, where all the data sent from the transmitter are known at the recipient and utilized for this estimation. This block is spoken to in Fig. 3, it is exceptionally straightforward where we ought to make a specific division with the known data (Training) and after that a normal is

done to get the impedance evaluated on every sub-carrier. These impedances are forward to the channel estimation block and the balance and identification obstruct for the following channel use.

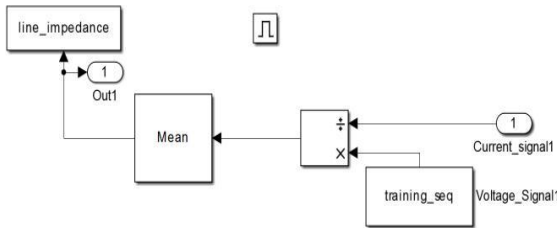

Figure 5: The block diagram of impedance estimation.

For the second channel utilize, the impedance estimator will be stopped and the channel estimator block and the equalizer block can work typically beginning from this second channel use until the end of the association. In this time, the sign contains data data and a little preparing arrangement utilized by the divert estimator spoke to in Fig. 4.

The channel estimation block is capable of evaluating the channel taps and assessing the SNR on every sub-carrier. The estimation of the channel taps is done just by doing a division between the known preparing grouping and the comparing got arrangement, since we work here in the frequency space. For the SNRs estimation, we are commit to work in every sub-carrier attempting to discrete the noise from the craved flag, and register the power of sought sign isolated by the power of the assessed noise. When we acquire these SNRs, they will be sent back to the transmitter and spared at the collector for the following use, which pick the mapping spectral on each subcarrier in comparing to the SNRs got and a specific limit picked by the strategy spoke to by S (i) in Fig. 5 and retained in the begin hinder at the transmitter.

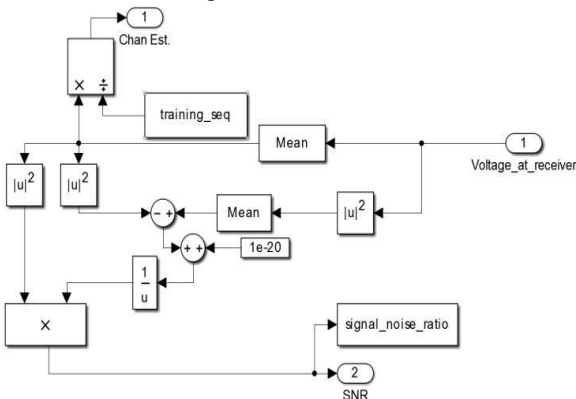

Figure 6: The block diagram of channel estimation

Since we work in the frequency area here after the FFT, so the equalizer's work is extremely straightforward, it has quite recently to isolate the got grouping by the evaluated channel (ensure that the assessed direct is in frequency space). The subsequent succession is than demapping with an alternate de-mapper on every sub-carrier. At last the bit stream yielded by the de-mapping is contrasted and the irregular bits produced at the transmitter and the BER is computed. The transmission rate (or phantom proficiency) of every transmission is fundamentally controlled by the tweak and channel coding mix. Three primary regulation plan are

considered here: i) Quadrature Phase Shift Keying (QPSK), ii) 16-Quadrature Amplitude Modulation (16-QAM) and iii) 64-QAM. For every situation, the tweak proficiency is equivalent to the quantity of bits per image that can be sent. On the off chance that the channel coding is utilized the productivity is duplicated by the coding rate. By altered Target BER, which represents application or administration sorts, the base SNR limit is set to accomplish the sought mapping plan as appeared in the Fig. 5. We note here that the objective BER decided for those qualities are thought to be equivalent to 10⁻³, however all in all it might to take a positive worth depending upon the administration advertised.

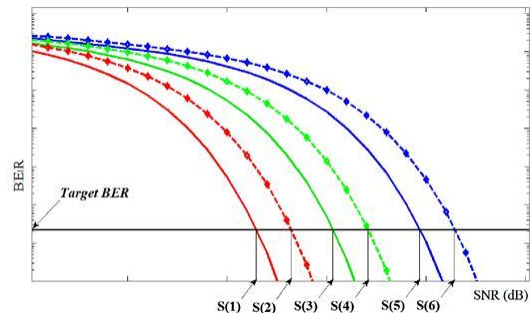

Figure 7: SNR thresholds selection for different mapping

B. PLC Channel and Additive Noise Model

Communicationsystemcharacteristics:It is important to distinguish possiblesources of obstruction and noise in light of the fact that the powerline has a critical lessening of sign and different noises. Accordingly the data exchange has a high error rate with no checking calculation. The basic impact on data transmission over powerlines is primarily the negative qualities of powernetworks. These qualities can be outlined in:

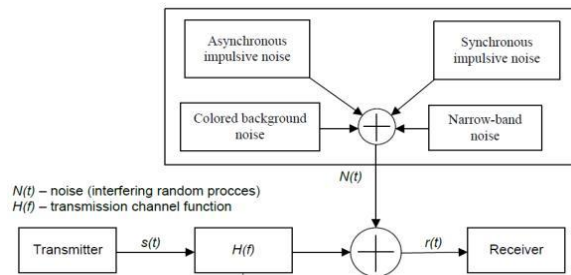

Figure 7: PLC channel model.

- 1- Mismatched impedance
- 2- Attenuation on the communication channel
- 3- Noise and Noise changing in time.

Figure 6 shows a rearranged block model of the PLC channel, in which the depicted qualities and parameters are included. The parameters of impedance, with the exception of noise, are spoken to as a period variable direct channel portrayed by the frequency parameters. Noise is delineated as added substance irregular procedure. This model catches the entire scope of parameters which are important for a model of the Communicationsystem with correspondence qualities, despite the fact that this model is schematically streamlined in the figure. The impulse reaction of the direct channel and the noise can be either evaluated from the

estimation or got from the hypothetical investigation. Here, they are figured by an immense number of estimations and the normal of every taken estimation is considered as a delegate model for the straight channel and the summation of various sort of noise introduced in Fig. 6. The impulse reaction and the frequency reaction of the direct channel are spoken to in Fig.7 and figure 8 shows a one shot time area estimation of the noise considered here.

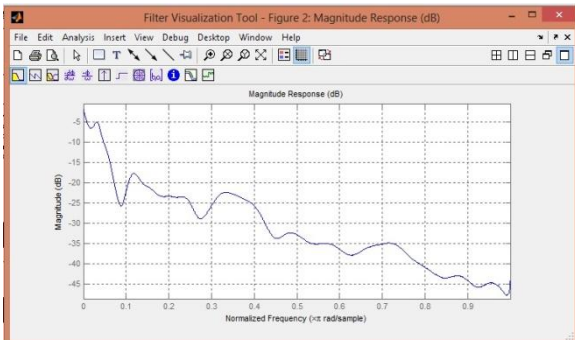

Figure 8: Magnitude Response of Digital Filter

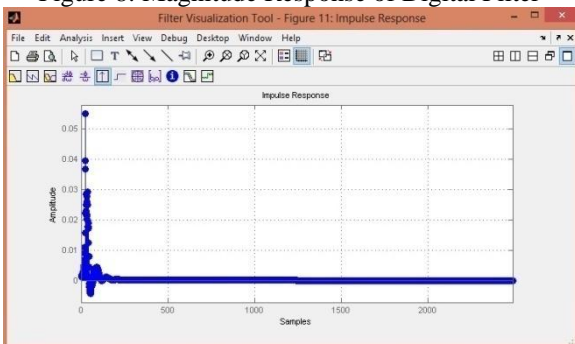

Figure 9: Impulse response of Digital Filter

IV. CONCLUSION AND FUTURE WORK

We manage configuration of the PLC Communication system model. The model is made out of the OFDM Communication show the model of power lines and noise model. The impedance crisscrossing is considered and with the channel model is assessed at the collector. Distinctive plan was mimicked to think about the bit error rate (BER). The reproduction model of the PLC-OFDM system connects well with run of the mill pragmatic systems. The error revision code is not utilized here. In the future work, we will plan a correspondence channel code which will be adapted and particularly to this application. The results of reproductions taking into account the model will be contrasted and estimations future work.

REFERENCES

[1] [Mlynek 2008] P. Mlynek, J. Misurec, M. Koutny, "The communication unit for wireless data acquisition via the Internet," In Proceedings of the 7th WSEAS International Conference on Circuits, networks, power, control and signal processing (CSES'08). Puerto de La Cruz, Spain: WSEAS Press, 2008.

[2] [Achmad 2007] R. Achmad, U. Agung, F. Tetsuo, K. Hidehiro, Y. T. Kyaw, U. Yoshiyori, U. Yuki, U. Yosuke, "Wireless LAN and power line

communication platform for e-learning multichannel network in underdeveloped area in Lombok island," in 6th WSEAS Int. Conf. on Power, Hardware, Wireless and Optical Communications, pages 23–28, 2007.

[3] [Koinakis 2009] C. J. Koinakis, J. K. Sakellaris, "Integration of building envelope and services via control technologies," in Proceedings of the 13th WSEAS international Conference on Networks, Rodos, Greece, July 22 - 24, 2009.

[4] [Orgon 2007] M. Orgon, "PLC/BPL and Next Generation Networks," in POWERCOM - Conference Communication over MV and LV power lines, Praha, 2007.

[5] [Berger 2013] L. T. Berger, A. Schwager, and J. J. Escudero-Garzas, "Power line communications for smart grid applications," Journal of Power and Computer Engineering, Vol. 2013, Article 712376, 16 pages, 2013.

[6] [Ferreira 1996] H. C. Ferreira, et al., "Power line communications: An overview," IEEE AFRICON 1996, 558-563, Stellenbosch, September 24-27, 1996.

[7] [Zwane 2014] F. Zwane, and T. J. Afullo, "An alternative approach in power line communication channel modeling," Progress In Electromagnetics Research C, Vol. 47, 85-93, 2014.

[8] [Lazaropoulos 2012] A. G. Lazaropoulos, "Broadband transmission characteristics of overhead high-voltage power line communication channels," Progress In Electromagnetics Research B, Vol. 36, 373-398, 2012.

[9] [Zimmermann 2002] M. Zimmermann, and K. Dostert, "A multipath model for the power line channel," IEEE Transactions on Communications, Vol. 50, No. 4, 553-559, April 2002.

[10] [Mulangu 2011] C. T. Mulangu, T. J. Afullo, and N. M. Ijumba, "Modelling of broadband power line communication channels," SAIEE, Vol. 102, No. 4, 107-112, December 2011.

[11] [Mulangu 2012] C. T. Mulangu, T. J. Afullo, and N. M. Ijumba, "Estimation of specific attenuation due to scattering points for broadband PLC channels," PIERS Proceedings, Kuala Lumpur, Malaysia, 92-96, March 27-30, 2012.

[12] [Zimmermann 2002] M. Zimmermann, and K. Dostert, "Analysis and modeling of impulsive noise in broad-band powerline communications," IEEE Transactions on Electromagnetic Compatibility, Vol. 44, No. 1, 249-258, November 2002.

[13] [Zimmermann 2000] M. Zimmermann, and K. Dostert, "Analysis of the broadband noise scenario in powerline networks," Proc. of ISPLC, 131-138, 2000.