

IoT BASED ENERGY EFFICIENT SYSTEM USING DYNAMIC TARIFF

Shilpa Gajjar¹, Prof. R. P. Sukhadia²

¹PG Scholar, ²Assistant Professor, Electrical Department, LDRP-ITR, Gandhinagar, Gujarat, India

Abstract: This paper focus on the design and implementation of IoT based energy efficient system using dynamic tariff. This design can be innovate the pattern of energy consumption by the different categories of the consumers as per the rate of tariff vary according to the variation in load on the system. The consumers of electricity can be plan for their consumption according to essential use of electricity and non-essential use of electricity as per the dynamic tariff. Indirectly consumer of electricity can be scheduling their consumption to get benefits by optimum utilization of electricity as per tariff changes or vary. This proposed system can be contribute to increase the load factor of the power system during off peak period by encouraging the consumers of electricity with the help of providing variation of rate charged to the consumers, this will results in the production cost of electricity per unit will be reduced. It will beneficial to both side's consumers as well as suppliers. This system provides monitoring facility to consumers to acquire knowledge of their consumption which will be helpful to plan their utilization of home appliance or domestic load.

I. INTRODUCTION

Prior study have shown that dynamic pricing can provide numerous benefits to utilities and customers alike by lowering the need for expensive peaking capacity ,improving system reliability and reducing power costs. The purpose of this project is to help to facilitate nationwide progress toward the development of dynamic pricing of electricity by summarizing information that may consist utilities and regulators. Who are assessing the business case for advanced infrastructure (AMI). Unlike oil or gas, electricity cannot easily be stored which means that electricity must be generated and delivered at the precise moment. It is needed supply must always equal to demand. Electricity providers must maintain capacity margins or supply that can be quickly brought on-line in the equipment failure or during period of peak demand. This capacity margin is met by maintaining generation facilities that are only used during a few hours of peak demand throughout the year. Most current residential electricity rate structure do not reflect the cost difference of supplying electricity in peal versus off-peak hours. Therefore the consumer has no market incentives to adjust his or her pattern of electricity consumption. Dynamic program charge higher electricity prices during periods of peak demand may be effective tools to shift electricity consumption to off peak hours. In this paper we include fundamental about IOT terms. What is the smart city and how we can make smart city. Also explaining basic concept about smart grid, Detail study about the term dynamic pricing and using this dynamic tariff how it

will beneficial for consumer and Also security of this system. In research gap also till date how much execution done.

II. DESIGN AND CONCEPT

The concept of Internet of Things (IoT) from its initial stage changing the current Internet into well featured upcoming internet. At present there are billions of gadgets (approximately nine billions) interconnected gadgets and one prediction is that it will reach up to fifty billions gadgets in 2020.

The IoT based energy efficient system using dynamic tariff comprises mainly 4 modules (units).

1. Micro controller unit
2. Ethenet module unit
3. HTML, PHP script for web server
4. Local Web server

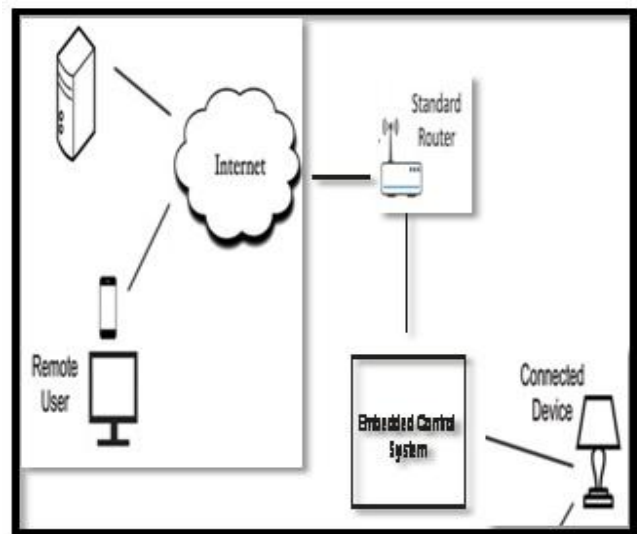

Fig-1 Basic diagram of an Energy efficient System using dynamic tariff

Internet of Things (IoT)

- The tem Internet of Things (IoT) was first used by Kevin Ashton in 1999.
- The IoT also called the Internet of Objects refers to wireless network between objects, usually the network will be wireless and self configuring such as household appliances.
- IoT refers to the concept that the internet is no longer just a global network for people to communicate with one another using computers, but it is a platform for device to communicate electronically with the world around them.
- The term Internet of Things has come to describe a number of technologies and research disciplines that

enable the internet to reach out into the real world of physical objects.

- Things having identities and virtual personalities operating in smart spaces using intelligent interface to connect and communicate within social, environmental and user context.
- The Internet of Things, also called the Internet of Objects, refers to a wireless network between objects, usually the network will be wireless and self configuring, such as household appliances.

The characteristics of Internet of Things (IoT) are as follows:-

- Its structure is flexible.
- It consist semantic sharing.
- It can access complex Technologies.
- It has capability of Event Driven.
- It consist Ambient Intelligence.



Figure-2 characteristic of Internet of Things (IoT)

III. APPLICATIONS OF IOT

As shown in figure below Internet of Things (IoT) can be applied in various field are as follows.

- Education
- Management
- Logistics
- Retail
- Pharmaceuticals
- Food

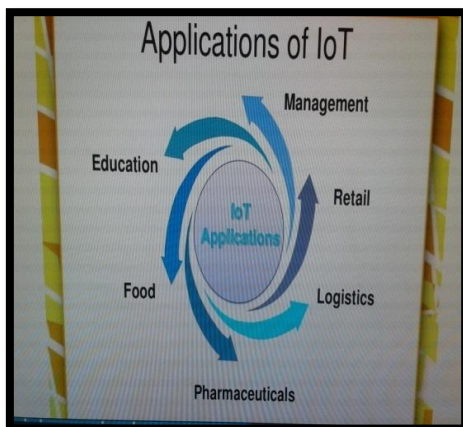

Figure-3 Applications of Internet of Things (IoT)

Smart city

- Smart Energy and Smart Grid
- Smart Mobility and Transport
- Smart Home, Smart Buildings and Infrastructures
- Smart Factory and Smart Manufacturing
- Smart Health
- Food and Water Tracking and Securities
- Smart Logistics and Retail



Fig 4- Smart Grid Concept

The above photograph shows a city of Spain which is developed by using smart city concept and this concept was executed by expenditure of 3.6 billions of dollars. In such concept of implementing of smart city there is a provision of electricity supply back up by using solar plant, wind farm, biomass etc. to ensure to continuity of supply.

Smart Grid

1. Concept of Smart Grid :-

- New metering and communication system, .e.g, “smart” meters: demand response; pricing options
- T&D investments to “modernize” communications, sensors, grid design and operation: manage outages; energy storage; intermittent resources Smart Home, Smart Buildings and Infrastructures
- Customer side of the meter: In Home Devices

2. Purpose of Smart Grid :-

- More efficient operations, .e.g. eliminate meter reading and field visit jobs
- Enable Demand Response programs: direct load control, dynamic pricing
- Enable distributed resources to be integrated into grid operations
- Improve reliability of service: outage detection and management
- Improve grid operations and efficiency; integrate renewable
- Link customer’s side of the meter to utility operations: in-home devices, appliances

Smart metering

1. Introduction:-

Advanced or smart meters: Only achieves part of this vision
 Most utilities focus primarily on Advanced Metering systems and rarely propose Smart Grid plans or investment decisions
 Smart Meter proposals often claim to represent crucial part of future Smart Grid plans
 Unknown ratepayer costs for investment to obtain modernization of the Transmission and Distribution grids

2. Consumer's concern about cost :-

- Utilities often seek separate tracker to assure cost recovery outside of a base rate case: consumers bear full responsibility for actual costs as they occur
- Potential for higher bills for low use and low income customers
- New technologies: who bears risk of wrong choice? [VCRs vs. DVDs vs. DVRs]
- Smart Metering proposals may be only a down payment on unknown future Smart Grid investments
- Rate impacts
- Technology obsolescence
- Retire existing working meters

3. Consumer's concern about Benefits :-

- Operational cost savings: elimination of jobs re meter reading; field operations
- Demand Response: implementation of dynamic pricing
- Energy conservation or consumption reduction
- Part of implementation of Smart Grid for T&D operations: integrate renewables; enable Electric Vehicles
- Benefits are estimated over a 15-20 year period; degree of accuracy never calculated
- To document cost effectiveness, utilities sometimes seek demand response and supply side benefits that make up over 50% of costs and that require estimates of future prices of capacity and energy
- Demand Response benefits have yet to be proven in any full scale implementation of dynamic pricing: customer participation rates; persistence of results; impacts of wholesale market structure on value of DR and means to return this value to customers
- Can low use and low income/elderly customers see benefits or only costs?
- Who bears the risk that these estimates are wrong?

4. Consumer's concern about Security :-

- Utilities typically couple smart metering with the functionality of remote connection and disconnection of the meter; disconnection for non payment should be accompanied by a premise visit and attempt to contact the customer to avoid disconnection
- These new meters may give rise to a host of degraded service options, e.g., prepayment (pay in advance and automatically disconnect when meter is not fed); service limiters
- New privacy concerns will become evident with the access to individual household usage information:

Is anybody home? What appliances are being used?
 Who can access this data and for what purpose?

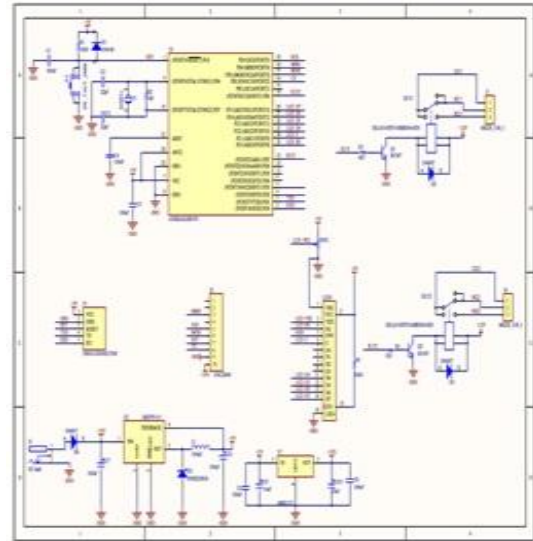

Fig 5- Circuit Diagram

IV. OPERATION OF THE IOT BASED ENERGY EFFICIENT SYSTEM USING DYNAMIC TARIFF

Consumer is a required to configure the device for dynamic pricing category. Device will operate according to the selected pricing category.

- (1) If device is configure for time of use(TOU);
 In this configuration device will simply turn ON/OFF the load based on the type of use.
- (2) If device is configure for critical peak pricing (CPP);
 In this configuration device will continuously fetch current unit rate from the web server and control the load according to be critical peak time specifies.
- (3) If device is configure for peak time rebates (PTR);
 In this configuration device will fetch quick time from the web server and keep control load in turn OFF state so that minimum energy will be consume during peak time. Consumer will get peak time rebate for the electricity provider.
- (4) If device is configure for real time pricing (RTP);
 Embedded device will continuously fetch current price from web server. If power unit price is found more than the threshold value set for to control load, the embedded device turn OFF load otherwise it will turn ON.

V. STATISTICAL ANALYSIS OF EXISTING TARIFF SYSTEM

sr. no	Chronological time(Hrs)	Unit consumed	Tariff Rate Rs/Kwh	Total bill amount in Rs.
1	12.00 AM TO 06.00 AM	2000	4.75	9500
2	06.00 AM TO 12.00 PM	3000	4.75	14250
3	12.00 PM TO 06.00 PM	1000	4.75	4750
4	06.00 PM TO 12.00 AM	3500	4.75	16625
total				45125

Table-1- STATISTICAL ANALYSIS OF EXISTING TARIFF SYSTEM

VI. STATISTICAL ANALYSIS OF DYNAMIC PRICING TARIFF SYSTEM

(1) If Dynamic pricing tariff types is Time of Use (TOU);
 If we consider 12.00 PM to 06.00 AM is TOU ;

Sr no	Chronological time(Hrs)	Tariff Rate Rs/Kwh	Unit consumed	Total bill amount in Rs.
1	12.00 AM TO 06.00 AM	5.00	2000	10000
2	06.00 AM TO 12.00 PM	6.00	0	0
3	12.00 PM TO 06.00 PM	4.75	3000	14250
4	06.00 PM TO 12.00 AM	6.05	0	0
total				24250

Table-2- If Dynamic pricing tariff types is Time of Use (TOU)

2) If dynamic pricing tariff type is Real time Pricing(RTP);

Sr no	Chronological time(Hrs)	Tariff Rate Rs/Kwh	Unit consumed	Total bill amount in Rs.
1	12.00 AM TO 06.00 AM	4.75	2000	9500
2	06.00 AM TO 12.00 PM	4.75	3000	14250
3	12.00 PM TO 06.00 PM	5.00	0	0
4	06.00 PM TO 12.00 AM	4.75	3500	16625
total				40375

Table-3 If dynamic pricing tariff type is Real time Pricing (RTP)

Advantages and Disadvantages of Proposed System

Advantages

- Operational cost savings: elimination of jobs re meter reading; field operations
- Demand Response: implementation of dynamic pricing
- Energy conservation or consumption reduction
- Part of implementation of Smart Grid for T&D operations: integrate renewables; enable Electric Vehicles
- Benefits are estimated over a 15-20 year period; degree of accuracy never calculated
- To document cost effectiveness, utilities sometimes seek demand response and supply side benefits that make up over 50% of costs and that require estimates of future prices of capacity and energy
- Demand Response benefits have yet to be proven in

any full scale implementation of dynamic pricing: customer participation rates; persistence of results; impacts of wholesale market structure on value of DR and means to return this value to customers

- Low use and low income/elderly customers see benefits in costs.
- Who bears the risk that these estimates are wrong?

Disadvantages

- The system must have sufficient data to be collected.
- Operator at control room must have computer competency to monitor and control the proposed system.

Actual picture of PCB design



Fig 6- Actual PCB (Hardware) Design

VII. CONCLUSION

Implementing this system user can monitor the tariff changed with time and optimum utilization of household and home appliances as per their beneficial tariff rate. This proposed system can also influence the load demand increase during the off peak period and helps to maintain the load factor within the off peak period This system helps to improve the overall economy per unit cost of electricity and also it will be beneficial to consumer rate of electricity utilization also.

REFERENCES

- [1] White Paper on Dynamic Pricing by Comverge, Inc.
- [2] Dynamic Pricing Tariffs for DTE’s Residential Electricity Customers Report No. CSS10-04, April 2010 Author: Arie Jongejan, Brian Katzman, Thomas Leahy, and Mark Michelin.
- [3] Dynamic Pricing of Electricity: A Survey of Related Research Author: Goutam Dutta, Krishnendranath Mitra W.P. No. 2015-08-03, August 2015, IIM Ahmedabad
- [4] IEE White Paper, June 2009 Moving Toward Utility-Scale Deployment of Dynamic Pricing in Mass Markets. The Edition Foundation, Electric Efficiency. Author: Ahmad Faruqui, Ph.D., Sanem Sergici, Ph.D., The Brattle Group, Lisa Wood, Ph. D., Institute for Electric Efficiency
- [5] IEE White Paper, September 2010 the Impact of

dynamic pricing on low income customers. The
Edition Foundation, Electric EfficiencyAuthor:
Ahmad Faruqui, Ph.D., Sanem Sergici, Ph.D., The
Brattle Group. Lisa Wood, Ph. D., Institute for
Electric Efficiency

- [6] Dynamic Pricing in a Moderate Climate: The
Evidence from Connecticut Ahmad Faruquia,*
Sanem Sergicib, and Lamine Akabaa1
A-The Brattle Group, 201 Mission Street, Suite
2800, San Francisco, CA 94105, USA
B-The Brattle Group, 44 Brattle Street, Cambridge,
MA 02138, USA