

# PERFORMANCE ANALYSIS OF QAM SIGNAL FOR OPTICAL COMMUNICATION SYSTEM

Shaat Ali Siddiqui<sup>1</sup>, Mr. Mukesh Tiwari<sup>2</sup>

<sup>1</sup>M.Tech, Digital Communication, SSSUTMS, Bhopal, India

<sup>2</sup>Dean Academic SSSUTMS, Bhopal, India

Department of Electronics & Communication Engineering

Sri Satya Sai University of Technology & Medical Science, Sehore, Bhopal

**ABSTRACT:** Quadrature amplitude modulation (QAM) is both an analog and a digital modulation scheme. It conveys two analog message signals, or two digital bit streams, by changing (modulating) the amplitudes of two carrier waves, using the amplitude-shift keying (ASK) digital modulation scheme or amplitude modulation (AM) analog modulation scheme. The two carrier waves of the same frequency, usually sinusoids, are out of phase with each other by 90° and are thus called quadrature carriers or quadrature components — hence the name of the scheme. The modulated waves are summed, and the final waveform is a combination of both phase-shift keying (PSK) and amplitude-shift keying (ASK). In 128-QAM and 256-QAM each symbol is represented by 7 bits and 8 bits respectively. As it increases in level QAM technique becomes more bandwidth efficient but it requires very robust algorithms to decode receiver into bits. QAM is more bandwidth efficient. Thus, in this paper performance Analysis of end to end quadrature amplitude modulation signal is proposed. The complete analysis of proposed design of 128-QAM and 256-QAM is simulated on AWR 5.3 simulating software. The results obtained from AWR simulated software is compared with Matlab results. The discussion and analysis of the results are done in terms of signal to noise ratio (SNR), bit error rate (BER) spectrum analysis at receiver and transmitter end, and constellation diagram.

**Keywords:** AM, FM, ASK, FSK, BPSK, QAM, MATLAB, AWR

## I. INTRODUCTION

Optical communication is any type of communication in which light is used to carry the signal to the remote end, instead of electrical current. Optical communication relies on optical fibers to carry signals to their destinations. A modulator/demodulator, a transmitter/receiver, a light signal and a transparent channel are the building blocks of the optical communications system. Because of its numerous advantages over electrical transmission, optical fibers have largely replaced copper wire communications in core networks in the developed world. Since the development of low-loss optical fiber cables in the 1970s, optical communications became one of the most popular methods of communication. Optical communication systems consist of the following components:

**Transmitter:** Converts and transmits an electronic signal into a light signal. The most commonly used transmitters are

semiconductor devices, such as light-emitting diodes (LEDs) and laser diodes.

**Receivers:** Typically consist of a photo-detector, which converts light into electricity using the photoelectric effect. The photo detector is typically a semiconductor-based photodiode.

**Optical Fiber:** Consists of a core, cladding and a buffer through which the cladding guides the light along the core by using total internal reflection.

The main benefits of optical communication include high bandwidth, exceptionally low loss, great transmission range and no electromagnetic interference. The cons of optic communication include the high cost of cable, transmitter/receiver and other support equipment, and the skill and expertise required during cable installation and interconnection.

## II. BLOCK DIAGRAM OF OPTICAL COMMUNICATION SYSTEM

When the input data, in the form of electrical signals, is given to the transmitter circuitry, it converts them into light signal with the help of a light source. This source is of LED whose amplitude, frequency and phases must remain stable and free from fluctuation in order to have efficient transmission. The light beam from the source is carried by a fiber optic cable to the destination circuitry wherein the information is transmitted back to the electrical signal by a receiver circuit.

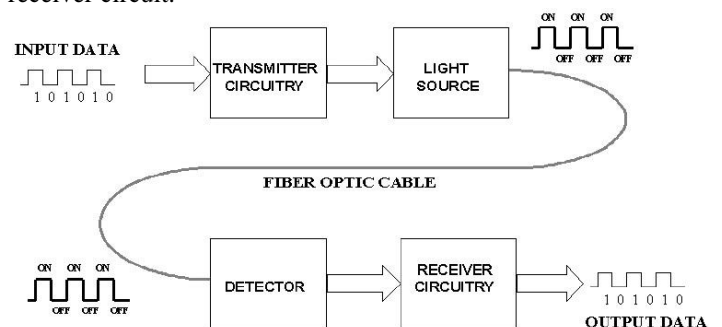

Working of Fiber optic communication

The Receiver circuit consists of a photo detector along with an appropriate electronic circuit, which is capable of measuring magnitude, frequency and phase of the optic field. This type of communication uses the wave lengths near to the infrared band that are just above the visible range. Both LED and Laser can be used as light sources based on the application.

III. BASIC ELEMENTS OF A FIBER OPTIC COMMUNICATION SYSTEM

There are three main basic elements of fiber optic communication system. They are

- Compact Light Source
- Low loss Optical Fiber
- Photo Detector

Accessories like connectors, switches, couplers, multiplexing devices, amplifiers and splices are also essential elements in this communication system.

1. COMPACT LIGHT SOURCE

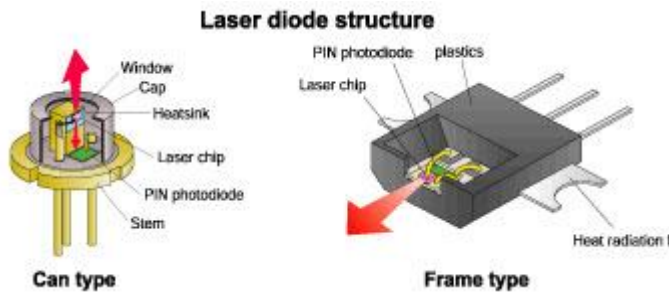

Laser Diodes

Depending on the applications like local area networks and the long haul communication systems, the light source requirements vary. The requirements of the sources include power, speed, spectral line width, noise, ruggedness, cost, temperature, and so on. Two components are used as light sources: light emitting diodes (LED's) and laser diodes.

The light emitting diodes are used for short distances and low data rate applications due to their low bandwidth and power capabilities. Two such LEDs structures include Surface and Edge Emitting Systems. The surface emitting diodes are simple in design and are reliable, but due to its broader line width and modulation frequency limitation edge emitting diode are mostly used. Edge emitting diodes have high power and narrower line width capabilities.

For longer distances and high data rate transmission, Laser Diodes are preferred due to its high power, high speed and narrower spectral line width characteristics. But these are inherently non-linear and more sensitive to temperature variations.

LED Versus Laser

Characteristic	LED	Laser
Output power	Lower	Higher
Spectral width	Wider	Narrower
Numerical aperture	Larger	Smaller
Speed	Slower	Faster
Cost	Less	More
Ease of operation	Easier	More difficult

Nowadays many improvements and advancements have made these sources more reliable. A few of such comparisons of these two sources are given below. Both these sources are modulated using either direct or external modulation techniques.

2. LOW LOSS OPTICAL FIBER

Optical fiber is a cable, which is also known as cylindrical dielectric waveguide made of low loss material. An optical

fiber also considers the parameters like the environment in which it is operating, the tensile strength, durability and rigidity. The Fiber optic cable is made of high quality extruded glass (Si) or plastic, and it is flexible. The diameter of the fiber optic cable is in between 0.25 to 0.5mm (slightly thicker than a human hair).

3. PHOTO DETECTOR

The purpose of photo detector is to convert the light signal back to an electrical signal. Two types of photo detectors are mainly used for optical receiver in optical communication system. PN photodiode and avalanche photodiode.

IV. DIFFERENT TYPES OF MODULATION TECHNIQUES

The digital communication brought many advantages over digital that of analog. These advantages can be represented in many features, as easy storage and faster processing. By using this, a huge amount of information can be carried. By using optical fiber, we may improve the transmission fidelity, increase in data rate and increase in transmission distance between transmitter and receiver. Its main advantages are very low attenuation and noise and a large bandwidth. Optical fiber gives higher bit rate in long distance transmission. This strength can be further achieved utilizing the advanced modulation formats. There are many benefits of using optic-fiber system over electric system and the main advantages of using fiber are its very low losses which allows long distances between repeaters, and its high data carrying capacity. By using single high bandwidth fiber, thousands of electric wires can be replaced. Unlike electrical transmission, optic-fiber experience no cross-talk. This relation is known as extinction ratio (ER) whose value depends on signal generation (direct or external modulation of laser source). When using external modulator, the ER of external modulator limits the ER of ASK.

AMPLITUDE SHIFT KEYING

The ASK type of modulation formats are simple to generate and detect. At the detection point the demodulation can be easily done by using a photo detector, which converts optical energy into electrical energy results in original transmitted pattern. In advanced optical communication system, to achieve more than one bit per symbol transmits two level binary signals instead of one bit per symbol. This increases the transmission capacity. This is known as multilevel signaling. According to the equation  $M=2^N$ , M shows the signal level and N is the number of bits per second and it is called M-ary signaling. For M=4, called 4-ary ASK, is mostly used which doubles the transmission capacity. For tripling the transmission capacity 8-ary ASK has also been reported but as channel capacity is improved by using 8-ary ASK, the OSNR and receiver sensitivity is degraded.

FREQUENCY SHIFT KEYING

When the frequency of a laser light is switched between the two frequencies is known as the frequency shift keying(FSK). In this modulation technique the envelope of optical signal does not change so in the comparison of ASK

the complexity of generating and receiving of the system increases. Modulation index is defined for the FSK system. The different modulation format based on FSK can be defined by changing the value of modulation index. A small change in modulation index results more compact optical spectrum. In already deployed system, a modulation format can not be replaced by FSK based modulation format because of the complexity of the receiving system. In this technique, the parameters of transmission line and the parameters of transmitter and receiver should exactly matched with each other.

**PHASE SHIFT KEYING**

The phase of the signal is used to modulate the signal in the phase shift keying( PSK). The phase of the binary data are modulated according to the phase of carrier signal. A constant signal envelope and a narrow spectrum of PSK optical signal results improve nonlinear tolerance of system. These type of signals are very sensitive about the phase modulation produced by multichannel effects. This produced phase modulation which can enhance the rate of error in decoding the received signal. In comparison of ASK formats, FSK gives a better receiver sensitivity. Because of a complex receiver, PSK did not receive much of interest, so another format of PSK is being used which is known as Differential phase shift keying(DPSK).

**QUADRATURE PHASE SHIFT KEYING(QPSK)**

Another extension of a Phase Shift Keying digital modulation technique is the division of the phase of the carrier signal designed by allotting four equally spaced values for phase angle is termed as Quadrature Phase Shift Keying. QPSK has four message points in the constellation diagram and so it becomes a highly bandwidth efficient. As the complexity increases at the receiver performance becomes less efficient so Root Raised Cosine pulse shaping is used for achieving better performance.

**V. RESULT AND DISCUSSION  
 CONSTELLATION DIAGRAMS**

A constellation diagram is a representation of a signal modulated by a digital modulation scheme such as quadrature amplitude modulation or phase-shift keying. It displays the signal as a two-dimensional X-Y plane scatter diagram in the complex plane at symbol sampling instants.

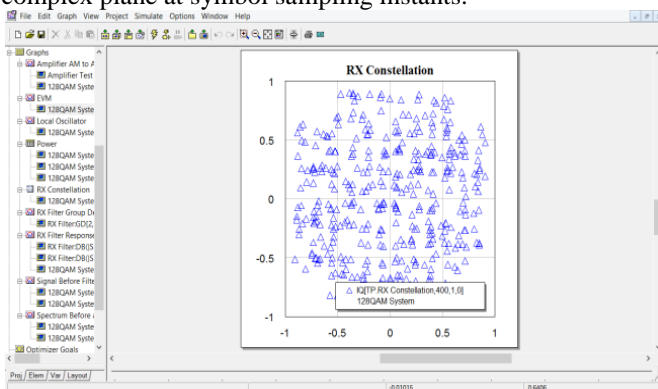

Constellation diagram of 128QAM

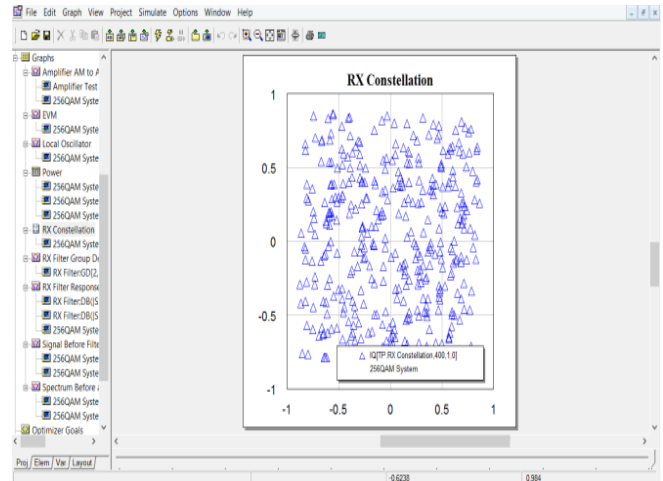

Constellation diagram for 256QAM

**RESULT ANALYSIS FOR EVM**

EVM stands for Error in Vector Magnitude. This graph shows errors occurring in the system. It is a vector analyzer.

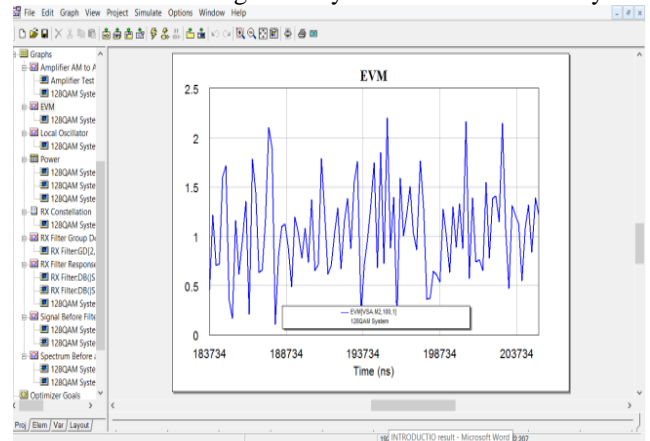

EVM analysis for 128QAM

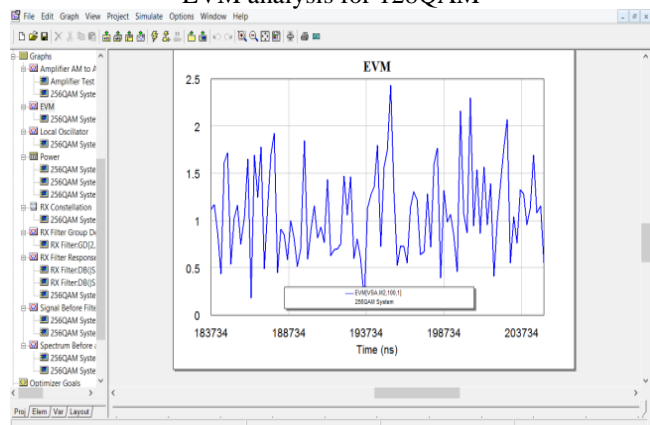

EVM analysis for 256QAM

**RESULT ANALYSIS FOR SPECTRUM BEFORE AND AFTER FILTER**

This graph shows the spectrum before using the filter and after using the filter before using the filter we can see that the response is not perfect it has some noise in it but after the



filter the spectrum is better and noise is reduced.

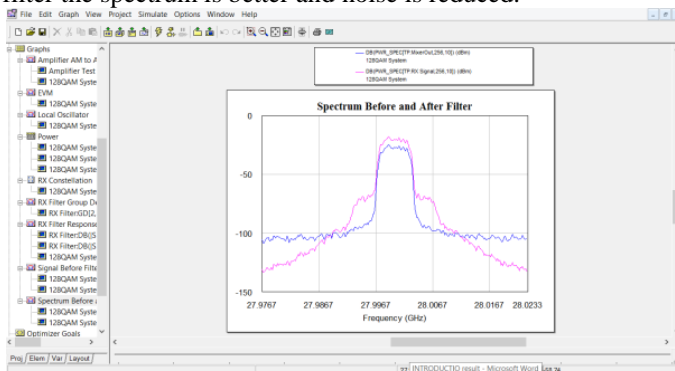

Analysis of spectrum before and after filter in 128QAM

### RESULT ANALYSIS FOR SIGNAL BEFORE FILTER AND AFTER DELAY

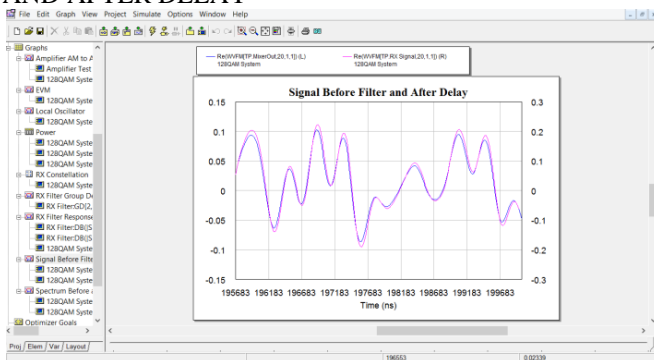

Signal analysis in 128QAM

### VI. CONCLUSION

This paper explains about transmission of high data rate with less power consumption and high bandwidth efficiency. I designed 128-QAM and 256-QAM in MATLAB according to the base papers we studied. To the addition to that we designed 128-QAM and 256-QAM in AWR software. QAM modulation technique is used because it is bandwidth efficient and consume less power. QAM is best modulation technique than other modulation technique inspite of some limitations. I designed our project in AWR software inspite of MATLAB because it gives the spectrum for each block. In AWR we are using filters which remove the noise occurred to some extent which is caused by increasing the number of bits to be transferred. So, as QAM is the easy technique to transfer high data rates with more efficiency over optical communication.

### REFERENCES

[1] Analysis and Simulation of LTE Downlink and Uplink Transceiver. Proceedings of the World Congress on Engineering 2014 Vol I, WCE 2014, July 2 - 4, 2014, London, U.K.  
[2] A Study on the Performance of IEEE 802.16-2004 Includes STBC ASEE 2014 Zone I Conference, April 3-5, 2014, University of Bridgeport, Bridgeport, CT, USA.  
[3] Performance Evaluation on the basis of Bit Error

Rate for different order of modulation and different length of sub channels of OFDM system. International Journal of Mobile Network Communications & Telematics( IJMNT) Vol. 4, No.3, June 2014.

[4] Performance Analysis of Amplify-and-Forward Non-Fixed Relays Cooperative Network with Relay Selection Journal of Computational Information Systems 6:9 (2010) 2901-2908.  
[5] Performance Analysis of the Dual-Hop Asymmetric Fading Channel. IEEE TRANSACTIONS ON WIRELESS COMMUNICATIONS, VOL. 8, NO. 6, JUNE 2009.  
[6] Simulink-based Simulation of Quadrature Amplitude Modulation (QAM) System. Xiaolong Li Indiana State University Ho, W. S., "Adaptive modulation (QPSK, QAM), www.intel.com/netcomms/technologies/wimax/303788.pdf, accessed on December30, 2007.  
[7] T. M. Cover and J. A. Thomas, Elements of Information Theory, 2nd edition. Hoboken, NJ: John Wiley & Sons, Inc., 2006.  
[8] R.-J. Essiambre, G. Kramer, P. J. Winzer, G. J. Foschini, and B. Goebel, "Capacity limits of optical fiber networks," IEEE Journal of Lightwave Technology, vol. 28, no. 4, pp. 662–701, Feb. 2010.  
[9] R. Dar, M. Feder, A. Mecozzi, and M. Shtaif, "On shaping gain in the nonlinear fiber-optic channel," in Proc. of IEEE International Symposium on Information Theory, July 2014, pp. 2794–2798.  
[10] B. P. Smith and F. R. Kschischang, "A pragmatic coded modulation scheme for high-spectral-efficiency fiber-optic communications," IEEE Journal of Lightwave Technology, vol. 30, no. 13, pp. 2047–2053, July 2012.  
[11] T. Fehenberger, G. B'ocherer, A. Alvarado, and N. Hanik, "LDPC coded modulation with probabilistic shaping for optical fiber systems," in Proc. of Optical Fiber Communication Conference (OFC), Mar. 2015, p. Th2A.23.  
[12] L. Beygi, E. Agrell, J. M. Kahn, and M. Karlsson, "Rate-adaptive coded modulation for fiber-optic communications," IEEE Journal of Lightwave Technology, vol. 32, no. 2, pp. 333–343, Jan. 2014.  
[13] F. Buchali, G. Bocherer, W. Idler, L. Schmalen, P. Schulte, and F. Steiner, "Experimental demonstration of capacity increase and rate-adaptation by probabilistically shaped 64-QAM," in Proc. of European Conference on Optical Communications (ECOC), Oct. 2015, p. PDP.3.4.  
[14] F. Buchali, F. Steiner, G. Bocherer, L. Schmalen, P. Schulte, and W. Idler, "Rate adaptation and reach increase by probabilistically shaped 64-QAM: An experimental demonstration," IEEE Journal of Lightwave Technology, vol. 34, no. 7, pp. 1599–1609, Apr. 2016.