

## OPTIMAL PLANNING OF DISTRIBUTED GENERATION SYSTEM IN DISTRIBUTED POWER SYSTEM

Alka Vishwakarma<sup>1</sup>, Shadab Khan<sup>2</sup>

Electrical & Electronics Engineering Department REC Bhopal

**Abstract:** This paper proposes and off-grid distributed generation system for the calculation of cost and reliability. The reliability is evaluated on the base of loss of power supply probability. The distributed generation system consist the component as PV, wind, battery and diesel generator for design the system. The system is programed in matlab envirement through the partical swarm optimazton technique. The design location of distributed generation has potential of renewable resources as soalr radiation and wind speed. The calculation of distributed generation system is considerd the probablistic nature of the resources.

### I. INTRODUCTION

In the recent years, India's energy consumption has been increasing at a quick rate within the world due to population growth and economic development [1]. In India, Industrial consumers are the largest group of electricity consumers, followed by the domestic, agricultural and commercial consumers, therein order. The Indian telecommunications trade is one in all the fastest growing industries within the world. India is presently adding 8–10 million mobile subscribers each month [2–7]. The facility woes of India's telecommunication sector particularly within the rural areas are quite apparent. It's a big challenge for the trade to satisfy its regular power needs through traditional fuel, that is pricey [8-9]. Power deficits in addition to the rising value of diesel create a major challenge to the mid-term growth and gain of the telecommunication sector. Continued reliance on diesel also will well increase the environmental prices within the kind of carbon emissions. The telecommunication sector is well placed to transit to a business model that depends on energy efficiency measures together with harnessing clean energy sources for its operations. This has compelled the trade to appear for various green energy solutions. India has one in all the best potentials for harnessing the renewable energy. Renewable energies are inexhaustible and clean. Renewable Energy Systems, significantly hybrid systems, have the extra advantage of being complimentary [10-11]. A hybrid system consists of two or additional renewable energy sources used along to supply green energy, increased system efficiency also as larger balance in energy supply. Thus, India's growing telecommunication tower trade are able to do substantial price savings, whereas reducing their fossil-fuel dependence and carbon footprint, by shift to hybrid renewable power generated electricity supply. The various Renewable Energy Sources (RES) like solar energy, wind energy, fuel cells so on are used for telecommunications applications within the developing countries.

All possible advantages of a hybrid energy system can be achieved only when system are designed and operated correctly. In these systems, sizing, control setting and operating schemes are interdependent. In accession, some of the system components have non-trivial behavior characteristics. Thus, task of the assessment of different design possibilities to plan a hybrid system for a specific location becomes very difficult.

### II. DISTRIBUTED GENERATION

Distributed generation (DG) is explained such as installation and process of miniature modular power generating technology that can be mutual with energy management and storage schemes. It is used to develop the operations of the electricity release systems at or near the closing stages user. Such schemes may or may not be associated to the electric grid. A DG system can utilize a range of technological preferences from renewable to non-renewable and can work either in a connected grid or off-grid system mode. The size of a DG system usually ranges from less than a kW to a few MWs. When the penetration of the DG becomes significant, the system dynamics can be largely affected. In this sense, the DG interconnection analysis is complex, especially taking into account the wide range of technologies and the typical configuration of the distribution networks which have been designed to operate with power flows only in one direction. Researchers and systems operators will need to focus on these challenges when incorporating DG on a large scale [14]. These limitations are enumerated as follows:

Reverse power flow: As a result of connecting DG in the system inducing malfunctions of protection circuits as they are configured at present. Reactive power: Many DG technologies use asynchronous generators that do not supply reactive power to the grid. Voltage level: The installed distributed generation changes the voltages profile of the distribution network because of the change in the magnitudes of power flow. Generally the voltages profile will tend to rise, which is not a trouble in congested networks with low voltage troubles, as would be in the contrary.

### III. ADVANTAGES OF DISTRIBUTED GENERATION

There are so many merits of distributed generation in the network of power system. The technical benifits of distributed generation are given as following

Energy Losses: The system loss reduction at the distribution system level could be one of the major benefits due to its impact on the utilities' revenue[12].

Environmental Benefits: Three main components to emissions from electricity production are namely carbon dioxide (CO<sub>2</sub>), nitrogen oxide (NO<sub>x</sub>) and sulphur dioxide

(SO<sub>2</sub>). These components are emitted from the centralized power plants due to burning fossil fuels. Emissions can be lowered by increasing the amount of clean and renewable energy DG resources in power systems, thereby reducing the usage of electricity generated from centralized power plants [13].

**Voltage Stability:** The DG placement and sizing of DG units for enhancing voltage stability in the distribution system are a new concept, but this topic has attracted the interest of some recent research efforts. Like the DG allocation for minimising power losses, most traditional methods for enhancing voltage stability have assumed that DG units are dispatchable and placed at the peak load [14-15].

**Economical Benefits:** The objective is to minimize the fuel cost and power losses. A planning framework was also developed for PV integration by reducing the investment, operation and imported energy costs [16]. Moreover, heuristic approaches were proposed to locate and size DG units with an objective of minimising the costs of investment, operation, imported energy and energy losses [17].

**Network Upgrade Deferral:** In the last decade, it has been reported that the network upgrade deferral is an attractive option for DG planning to meet load growth [39-40]. The study in [18] showed that depending on technologies adopted, DG units have diverse impacts on the network deferral

**Voltage Profiles:** The voltage profile issue of distribution systems, which is relevant to power quality, is normally less important than the energy loss from the viewpoint of utilities. However, in recent years, it appears that due to high intermittent renewable DG penetration, there has been an increasing interest in the voltage profile issue at the distribution system level [17].

IV. DESIGN OF HYBRID SYSTEM

The design of distributed generation through the renewable energy sources. Solar radiation and wind speed both are freely available in environment. For optimal design of distributed generation system it is necessary the yearly average data of solar radiation and wind speed are high. The design location is Bhopal, India for distributed generation system. The components of distributed generation are photovoltaic, wind turbine both as source, battery is use for storage purpose/ back-up. The diesel generator is use to fulfill the load requirement whenever the generation is less through the renewable sources. The converter also used in distributed generation for conversion of AC to DC and DC to AC. The table 1 show the cost information of the all components used for design of distributed generation.

Table 1 Cost of each component in \$.

S.N.	Component	Initial Cost	Replacement Cost	O/M Cost
	PV	3000	2500	00
	Wind	1450	1230	00
	Battery	280	195	5.0
	Converter	620	450	00

PHOTOVOLTAIC ARRAY

A solar panel is a set of solar photovoltaic modules electrically connected and mounted on a supporting structure. A photovoltaic module is a packaged, connected assembly of solar cells. The solar panel can be used as a component of a larger photovoltaic system to generate and supply electricity in commercial and residential applications. The performance of PV module is a function of the physical variables of the PV cell material, one being the temperature of solar irradiance exposed on the solar cells [134-135]. Solar modules use light energy (photons) from sun to generate electricity through photovoltaic effect.

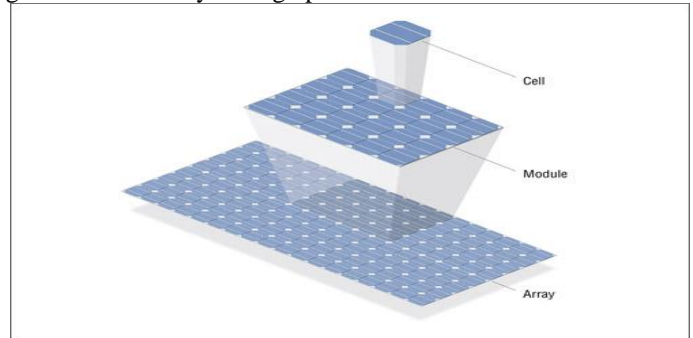

Fig. 4.1 Photovoltaic system

Wind Power Generation

Wind power generation mainly depends on availability of wind and design parameters of the WTG unit. The main characteristics that influence generated power are the cut-in wind speed, cut-out wind speed, rated wind speed, and the rated power. Wind power generation varies non-linearly with the wind speed. A typical characteristic curve is shown in Figure 6. It can be seen from Figure 6 that wind turbines are generally designed to generate power at specific minimum wind speed. This wind speed is called cut-in wind speed,  $V_{ci}$ . The generated power increases non-linearly as shown in Figure 6 with increase in wind speed from  $V_{ci}$  to the rated wind speed,  $V_r$ . A WTG generates the rated power  $P_r$  at rated wind speed. Wind turbines are designed to stop at high wind speed in order to avoid damage to turbine. This maximum allowable wind speed is called cut-out wind speed,  $V_{co}$ . The power generated remains constant at the rated power level  $P_r$  when the wind speed varies between rated wind speed and cut-out wind speed. The output power  $P_{WTG}$  (kW/m<sup>2</sup>) from wind turbine generator (WTG) for wind speed  $V_t$  can be expressed as [8]:

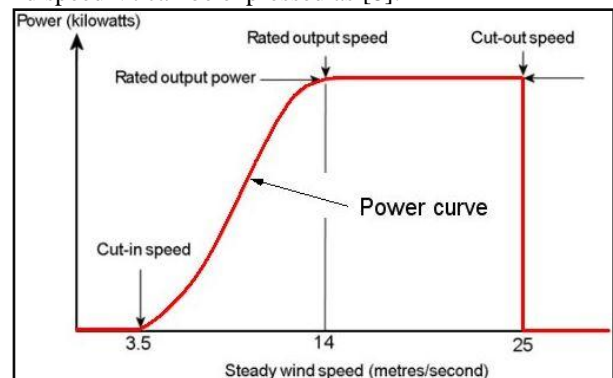

Figure 4.4 Typical wind turbine power curve

**Battery bank storage**

The photovoltaic and wind being intermittent sources of power, cannot meet the load demand all the time. The energy storage is, therefore, a desired feature to incorporate with hybrid energy system, particularly in stand-alone systems. It can significantly improve the load availability, a key requirement for any hybrid energy system.

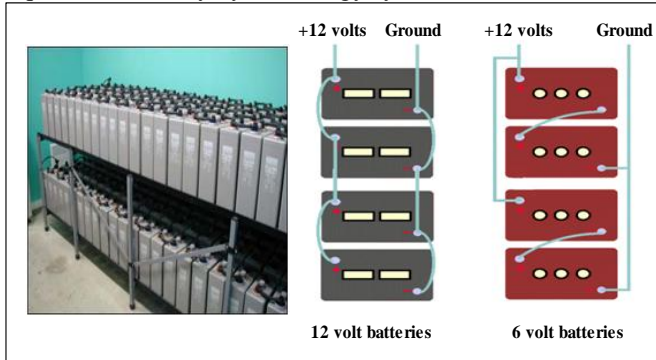

Figure 4.5 Typical battery bank used in hybrid system and its connections

The choice of the right size of battery bank for a particular application that involves the analysis of battery charging and discharging. If the renewable sources produces power more than the demand, this surplus power is used to charge the batteries. Figure 8 show the block basic diagram of hybrid renewable energy system (HRES). If in case these renewable resources are unable to meet the load demand, than deficit power is provided by the batteries. The system efficiency is largely dependent on battery ageing and thus batteries need to be replaced as and when required.

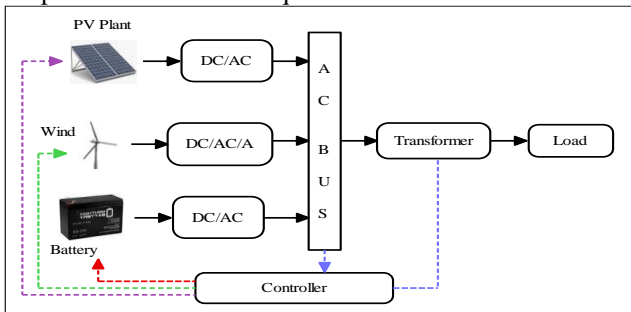

Figure 4.6 show the block basic diagram of hybrid renewable energy system

**V. OPTIMIZATION TECHNIQUES**

**Particle swarm optimization**

The Particle Swarm Optimization (Kennedy & Eberhart in 1995) is a well-known optimization algorithm based on population of swarms. Throughout the PSO, the particle has a tendency to fly nears a promising region in the search space. The Particle Swarm Optimization (PSO) process initializes the random position of particles and updates their particles position based on the personal and neighbor's best experience [7],[9]. The updated value of position depends on the updated values of the velocity in each generation (or iteration).

$$r^i = y^i * r^{i-1} + c_1 z_1 (h_{pbest}^{i-1} - h^{i-1}) + c_2 h_2 (h_{gbest}^{i-1} - h^{i-1}) \quad (1)$$

$$h^i = r^i + r^{i-1}$$

(2)

**VI. CONSTRAINTS**

The swept area of WTGs should be within a certain range

$$A_{w_{min}} \leq A_w \leq A_{w_{max}} \quad 2$$

The area of PV arrays should also be within a certain range

$$A_{s_{min}} \leq A_s \leq A_{s_{max}} \quad 3$$

Where,

$A_{w_{min}}$  = Minimum wind swept area in  $m^2$ ,  $A_{w_{max}}$  = Maximum wind swept area in  $m^2$   
 $A_{s_{min}}$  = Minimum PV panel area in  $m^2$ ,  $A_{s_{max}}$  = Maximum PV panel area in  $m^2$

**VII. RESULT AND DISCUSSION**

The optimal result are calculated for design location Bhopal, India. The reliability is calculated on base on loass of power supply probability. The laod of design location is considered as constant load 67kW. The sizing is evaluated of the 24 hourly base of day. The lifespan of the design project is for 20 years. The program is design in matlab m-file through the PSO tool. The optimization is done for 100 iteration. The figure 4 and 5 show the result for realtion between cost and project life, The figure 5 show the relation of reliability .

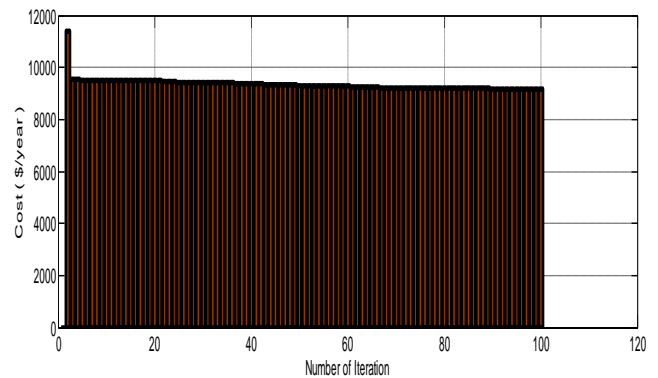

Fig relation between year and cost

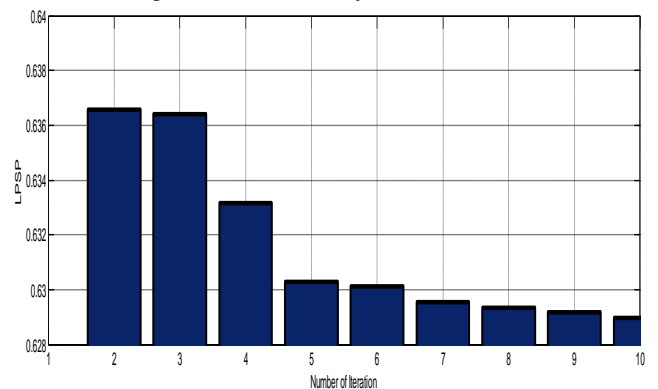

Fig 5 reliability with varing factors

### VIII. CONCLUSION

The paper proposed an optimal distributed generation design of off-grid PV, wind hybrid system. The output results of the system give lowest cost of the system also provided environment pleasant solution of distributed generation. The distributed generation system reliability is calculated on the base of loss of power supply probability (LPSP). The design of , wind hybrid system fulfill the load requirement of particular distributed generation location. The distributed generation is also considered the uncertainties nature of solar radiation and wind speed.

### REFERENCE

- [1] Dmowski Antoni, Pictor Biczal, Kras Bartlomiej. Hybrid solar panel fuel cell power plant, 11; 2001; 22–3.
- [2] Nelson DB, Nehrir MH, Wang C. Unit sizing of stand-alone hybrid wind/PV/fuel power generation systems. *Renew Energy* 2006;31:1641–56.
- [3] Larmine J, Dicks A. Fuel cell systems explained. 2nd ed.. England: Wiley; 2003; 2003.
- [4] Iqbal MT. Modeling and control of a fuel cell hybrid energy system. *Renew Energy* 2007;28:223–37.
- [5] Hansen Jens Carsten, Lundsager Per and Nielsen Lars Henrik, Energy Report 4, Risø National Laboratory, Denmark, 2007, p. 21–7.
- [6] Sawle, Y and S. C. Gupta “A novel system optimization of a grid independent hybrid renewable energy system for telecom base station” *International Journal of Soft Computing, Mathematics and Control (IJSCMC)*, Vol. 4, No. 2, pp. 49-57, May 2015.
- [7] Sawle, Y and S. C. Gupta, “Optimal sizing of a pv/biomass hybrid system with battery, storage for rice mill electrification to an off-grid remote area” *ciencia e tecnica vitivinicola journal*, Vol. 30 ,NO. 3, pp. 173-194, March 2015.
- [8] Sawle, Y., Gupta, S. C., & Kumar Bohre, A. (2016). PV-wind hybrid system: A review with case study. *Cogent Engineering*, 3(1), 1189305.
- [9] Sawle, Y, and S. C. Gupta. "Optimal sizing of photo voltaic/wind hybrid energy system for rural electrification." In *Power India International Conference (PIICON)*, 2014 6th IEEE, pp. 1-4. IEEE, 2014.
- [10] Doumbia Mamadou Lamine, Agbossou Kodjo. Photovoltaic/wind energy system with hydrogen system. 2009; 249–65.
- [11] Li Chun-Hua, Zhu Xin-Jian, Cao Guang-yi, Sui Sheng, Hu Ming-Ruo. Dynamic modeling and sizing optimization of stand-alone photovoltaic power systems using hybrid energy storage technology. *Renew Energy* 2009;39:815–26.
- [12] S. Diaf, G. Notton, M. Belhamel, M. Haddadi, A. Louche, “Design and techno economical optimization for hybrid PV-wind system under various meteorological conditions”, *Appl. Energy*, vol.85, pp.968 -87, 2008.
- [13] R. Dufo-Lopez, J.L. Bernal-Agustin, “Design and control strategies of PV-diesel system using genetic algorithm”, *Solar energy*, vol.79, pp.33 -46, 2005.
- [14] R. Viral, D.K. Khatod, “Optimal planning of distributed generation system in distributed system”, *A review Renew and Sustainable Eng Review* vol.16, pp.5146 -65, 2012.
- [15] N. L. Panwar, S. C. Kaushik, K. Surendra, “Role of renewable energy sources in environmental protection: A review”, *Renewable and Sustainable Energy Reviews*, vol.15, pp.1513-24, 2011.
- [16] T. Ackermann, G. Anderson, L. Soder, “Distributed generation: a definition”, *Electric Power System Research*, vol.57, pp.195 -204, 2001.
- [17] P.S. Georgilakis, Y.A. Katsigiannis, “Reliability and economic evaluation of small autonomous power systems containing only renewable energy sources”, *Renew Energy*, vol.34, pp.65-70, 2009.
- [18] S.M. Hakimi, S.M. Tafreshi, “Optimal sizing of a stand-alone hybrid power system via particle swarm optimization for kahnouj area in south-east of Iran”, *Renewable Energy*, vol.34, pp.1855 -1862, 2009.