

## NOVAL TECHNIQUE TO SIMULATE THE HYBRID POWER SYSTEM IN MATLAB

Pooja<sup>1</sup>, Dr. Rakesh Joon<sup>2</sup>

<sup>1</sup>M. Tech (ECE), <sup>2</sup>HOD, Dept. Of ECE, GITAM, Kablana

**ABSTRACT:** Solar hybrid power systems are hybrid power systems that combine solar power from a photovoltaic system with another power generating energy source. A common type is a photovoltaic diesel hybrid system, combining photovoltaic's (PV) and diesel generators, or diesel gensets, as PV has hardly any marginal cost and is treated with priority on the grid. The diesel gensets are used to constantly fill in the gap between the present load and the actual generated power by the PV system. . In fact, the traditional sizing procedures find optimum number of the PV modules and wind turbines subject to minimum cost. However, the optimum battery capacity is either not taken into account, or it is found by a full search between all probable solution spaces which requires extensive computation. The main objective of the thesis is to implement a power system that is a hybrid of both Photovoltaic and wind powers. The step by step objectives are to study and model PV cell, PV array and PV panels. To study the characteristic curves and effect of variation of environmental conditions like temperature and irradiation on them. To study the PV module's behavior under partial shading condition. To trace the maximum power point of operation the PV panel irrespective of the changes in the environmental conditions. To study and simulate the wind power system and track its maximum power point Implement hybrid system. This research were taken during the operation of the data acquisition, for a temperature of 24.5 C, an irradiation of 610 W/m<sup>2</sup> and a wind speed of 8.6 m/s. Obtained results using MATLAB Software. The PV current is almost constant; the same for the PV voltage which remains constant around 24 V for 30 days of period of observation. We can conclude that the control strategy can supervise efficiently and maintain the battery voltage constant.

**Keyword:** Solar hybrid power, diesel generators, PV system, hybrid system, MATLAB Software.

### I. INTRODUCTION TO HYBRID SYSTEM

Due to the critical condition of industrial fuels which include oil, gas and others, the development of renewable energy sources is continuously improving. This is the reason why renewable energy sources have become more important these days. Few other reasons include advantages like abundant availability in nature, eco-friendly and recyclable. Many renewable energy sources like solar, wind, hydel and tidal are there. Among these renewable sources solar and wind energy are the world's fastest growing energy resources. With no emission of pollutants, energy conversion is done through wind and PV cells. Day by day, the demand for electricity is rapidly increasing. But the available base load plants are not

able to supply electricity as per demand. So these energy sources can be used to bridge the gap between supply and demand during peak loads. This kind of small scale stand-alone power generating systems can also be used in remote areas where conventional power generation is impractical. In this paper, a wind-photovoltaic hybrid power generation system model is studied and simulated. A hybrid system is more advantageous as individual power generation system is not completely reliable. When any one of the system is shutdown the other can supply power. A block diagram of entire hybrid system is shown below.

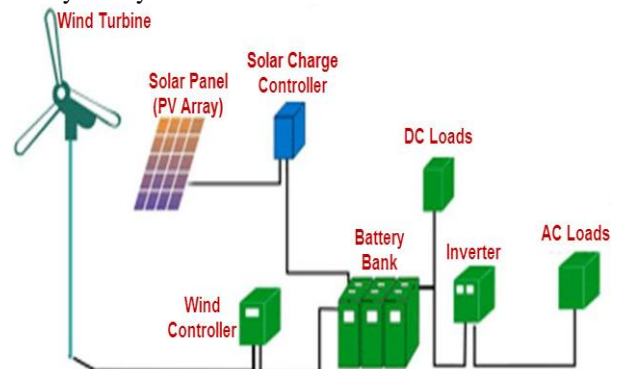

Fig 1.1: Block diagram of hybrid system

The entire hybrid system comprises of PV and the wind systems. The PV system is powered by the solar energy which is abundantly available in nature. PV modules, maximum power point tracing systems make the PV energy system. The light incident on the PV cells is converted into electrical energy by solar energy harvesting means. The maximum power point tracking system with Perturb & absorb algorithm is used, which extracts the maximum possible power from the PV modules. The ac-dc converter is used to converter ac voltage to dc.

### II. OBJECTIVES

The main objective of the thesis is to implement a power system that is a hybrid of both Photovoltaic and wind powers. The step by step objectives are

- To study and model PV cell, PV array and PV panels.
- To study the characteristic curves and effect of variation of environmental conditions like temperature and irradiation on them.
- To study the PV module's behavior under partial shading condition.
- To trace the maximum power point of operation the PV panel irrespective of the changes in the environmental conditions.
- To study and simulate the wind power system and

track its maximum power point Implement hybrid system.

2.1 HISTORY

In 1839, a French physicist Edmund Becquerel proposed that few materials have the ability to produce electricity when exposed to sunlight. But Albert Einstein explained the photoelectric effect and the nature of light in 1905. Photoelectric effect state that when photons or sunlight strikes to a metal surface flow of electrons will take place. Later photoelectric effect became the basic principle for the technology of photovoltaic power generation. The first PV module was manufactured by Bell laboratories in 1954.

III. PV CELL

A solar cell is an electronic device which directly converts sunlight into electricity. Light shining on the solar cell produces both a current and a voltage to generate electric power. This process requires firstly, a material in which the absorption of light raises an electron to a higher energy state, and secondly, the movement of this higher energy electron from the solar cell into an external circuit. The electron then dissipates its energy in the external circuit and returns to the solar cell. A variety of materials and processes can potentially satisfy the requirements for photovoltaic energy conversion, but in practice nearly all photovoltaic energy conversion uses semiconductor materials in the form of a p-n junction.

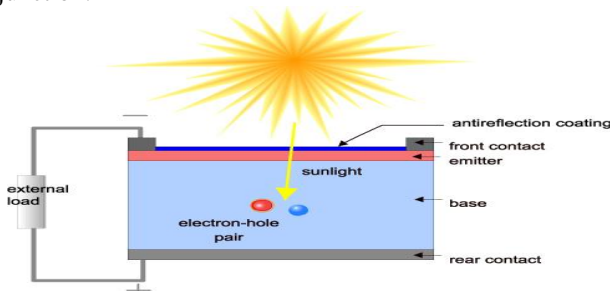

Fig 3.1: Actual understanding of PV system

The basic steps in the operation of a solar cell are:

- ✓ The generation of light-generated carriers;
- ✓ The collection of the light-generated carries to generate a current;
- ✓ The generation of a large voltage across the solar cell; and
- ✓ The dissipation of power in the load and in parasitic resistances.

IV. PROPOSED WORK

4.1 IMPLEMENTATION OF HYBRID ENERGY SYSTEM

Intermittent energy resources and energy resources unbalance are the most important reason to install a hybrid energy supply system. The Solar PV wind hybrid system suits to conditions where sunlight and wind has seasonal shifts. As the wind does not blow throughout the day and the sun does not shine for the entire day, using a single source will not be a suitable choice. A hybrid arrangement of combining the power harnessed from both the wind and the sun and stored in a battery can be a much more reliable and realistic power

source. The load can still be powered using the stored energy in the batteries even when there is no sun or wind. Hybrid systems are usually built for design of systems with lowest possible cost and also with maximum reliability. The high cost of solar PV cells makes it less competent for larger capacity designs. This is where the wind turbine comes into the picture, the main feature being its cheap cost as compared to the PV cells. Battery system is needed to store solar and wind energy produced during the day time. During night time, the presence of wind is an added advantage, which increases the reliability of the system. In the monsoon seasons, the effect of sun is less at the site and thus it is apt to use a hybrid wind solar system.

V. SIMULATION AND RESULTS

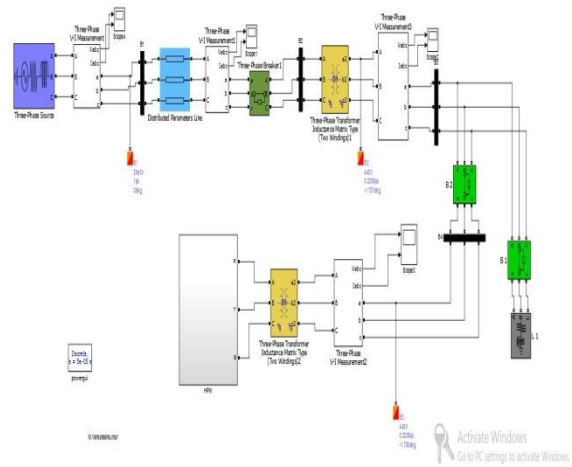

Fig 5.1 Basic Layout

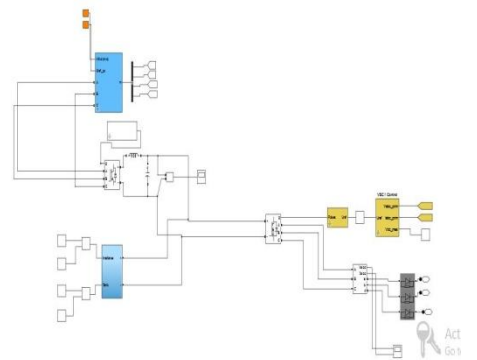

Fig 5.2: Layout of HPW

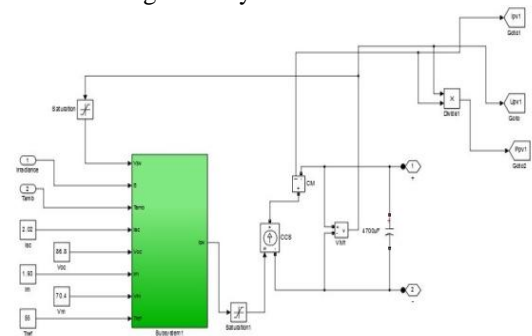

Fig 5.3: Subsystem of HPW

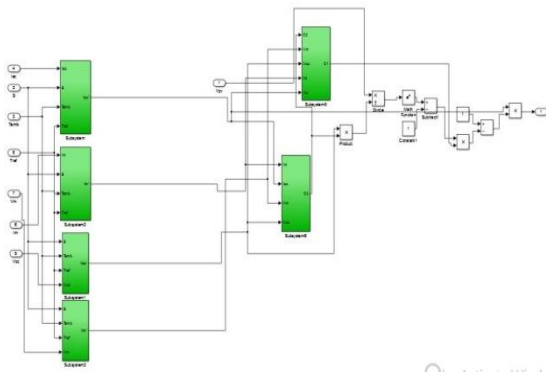

Fig 5.4: Different Subsystem of HPW

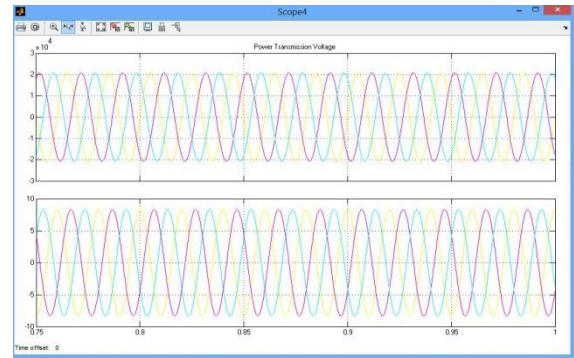

Fig 5.8: Output of Three-Phase V-I Measurement (Hybrid)

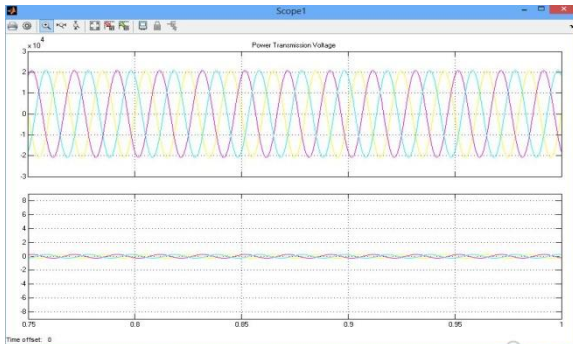

Fig 5.5: Output of Three-Phase V-I Measurement (For Turbine-Measure for 1 month period)

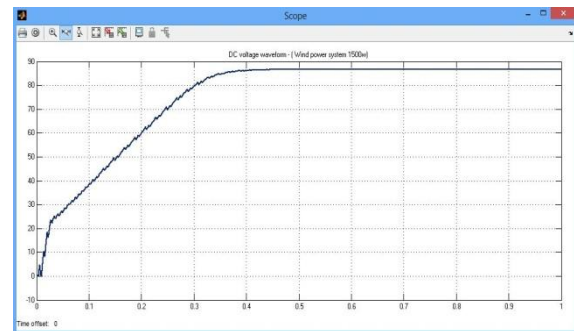

Fig 5.9: Wind Power DC Voltage Waveform (Battery)

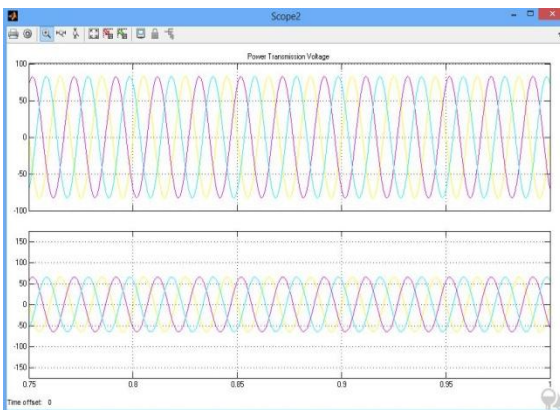

Fig 5.6: Output of Three-Phase V-I Measurement3 (Photovoltaic voltage for 1 month)

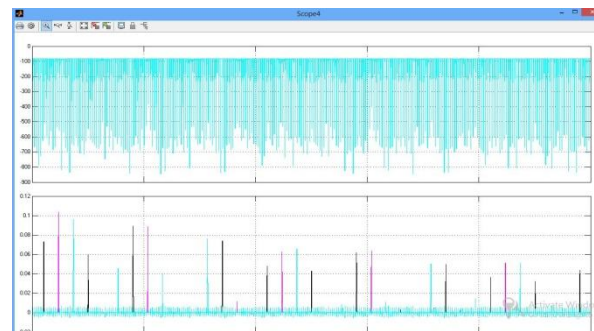

Fig5.10: Three phase VI measurement (Hybrid+battery)

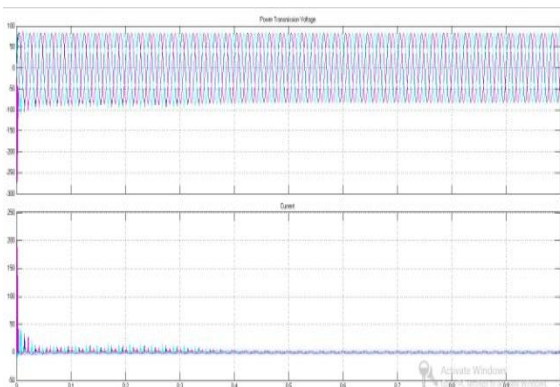

Fig 5.7: Output of Three-Phase V-I Measurement2-Current Measurement

Experimental results presented in this section have been obtained from the hybrid system using MATLAB simulation diagram. The following figures were taken during the operation of the data acquisition, for a temperature of 24.5 C, an irradiation of 610 W/m<sup>2</sup> and a wind speed of 8.6 m/s. Obtained results using MATLAB Software are represented in the following figures (Figs. 5.3-5.10). We note that the wind voltage and current waveforms are sinusoidal. The PV current is almost constant; the same for the PV voltage which remains constant around 24 V for 30 days of period of observation. We can conclude that the control strategy can supervise efficiently and maintain the battery voltage constant.

## VI. CONCLUSION

In this Research, identification and implementation of hybrid photovoltaic/wind/battery system have been proposed. The proposed system is simple due to the reduced number of its components and it is accurate due to its exact of electronic circuits. We have used MATLAB Software which allows a

real-time acquisition of electrical parameters. Data acquisition card is chosen to perform an acquisition of different voltages and currents sensors of the global system. In order to achieve this, we realized the different sensors to use MATLAB processes the signals and displays the expected values on a computer screen. The power management strategy proposed is simple. It has been studied to manage the power flow of energy systems and battery to supply the load demand. It clearly shows that the proposed hybrid system and its management control strategy are suitable for an implementation in a real application as in electrification or pumping water for standalone areas.

#### REFERENCES

- [1] Guillermo Velasco-Quesada, Francisco Guinjoan "Electrical PV Array Reconfiguration Strategy for Energy Extraction Improvement in Grid-Connected PV Systems" IEEE Transactions On Industrial Electronics, Vol. 56, No. 11, November 2009 4319 0278-0046/\$26.00 © 2009 IEEE.
- [2] Jonathan Storey, Peter Wilson "Improved Optimization strategy for Irradiance Equalization in Dynamic Photovoltaic Arrays" Manuscript received May 15th, 2012.
- [3] Vijayalekshmy S, Bindu G R, and S Rama "Estimation of Power Losses in Photovoltaic Array Configurations under Passing Cloud Conditions" Proceedings of the World Congress on Engineering 2014 Vol I, WCE 2014, July 2 - 4, 2014, London, U.K. ISBN: 978-988-19252-7-5 ISSN: 2078-0958 (Print); ISSN: 2078-0966 (Online) WCE 2014.
- [4] Saravanan Kaliyaperumal, Sharmeela Chenniyappan "Low cost Dynamic Switching Technique for Improving the Power in Partially Shaded Photovoltaic Array" International Journal of Control and Automation Vol.9, No.2 (2016), pp.61-70 <http://dx.doi.org/10.14257/ijca.2016.9.2.07> ISSN: 2005-4297 IJCA Copyright © 2016 SERSC.
- [5] Paula dos Santos Vicente, Tales Cleber Pimenta, and Enio Roberto Ribeiro "Photovoltaic Array Reconfiguration Strategy for Maximization of Energy Production" Hindawi Publishing Corporation International Journal of Photo energy Volume 2015, Article ID 592383, 11 pages <http://dx.doi.org/10.1155/2015/592383>
- [6] R.L. Josephine, S. Suja, G. Karunambika "Combination of fixed configuration and reconfiguration method for maximum power extraction from PV arrays" Advances in Natural and Applied Sciences, 8(20) Special 2014, Pages: 67-72. R.L.Josephine., Department of Electrical and Electronics Engineering, Coimbatore Institute of Technology, Coimbatore, India.
- [7] V. Di Dio, D. La Cascia, C. Rando, G. Ricco Galluzzo "A new control system prototype for the energy production maximization of a unequally irradiated PV system" Copyright © 2011 MC2D & MITI University of Palermo - DIEET (Department of Electrical Electronic and Telecommunications Engineering) Viale delle Scienze, Edificio 9, 90128 Palermo.
- [8] F.Z. Zerhouni, M.H. Zerhouni, M. Zegrar, M.T. Benmessaoul, A. Boudghene Stambouli "Increasing The Efficiency Of The Photovoltaic (PV) Array Utilization With Experimental Results" International Conference on Renewable Energies and Power Quality (ICRE PQ'14) Cordoba (Spain), 8th to 10th April, 2014 ISSN 2172-038 X, No.12, April 2014.
- [9] D. Picault a,\*, B. Raison a, S. Bacha a, J. de la Casa b, J. Aguilera b "Forecasting photovoltaic array power production subject to mismatch losses" Received 16 February 2010; received in revised form 9 April 2010; accepted 10 April 2010 Available online 12 May 2010.