

# IOT CONTROLLED METAL DETECTING ROBOT WITH REMOTE VIDEO TRANSMISSION TO ASSIST BOMB DETECTION AND RESCUE TEAM USING RPI

Narendra Prasad M

Assistant Professor in Department of ECE, Sri Indu College of Engineering & Technology, Hyderabad

## I. INTRODUCTION

A common definition of terrorism is the systematic use or threatened use of violence to intimidate a population or government for political, religious, or ideological goals. Terrorism in India, according to the Home Ministry, poses a significant threat to the people of India. Terrorism found in India includes ethno-nationalist terrorism, religious terrorism, left wing terrorism and narco terrorism. This includes bomb blasts also. We have introduced a project to detect the bombs.

### Existing system

This robot is controlled by a RF remote. This can be moved forward and reverse direction using DC motors. Also this robot can take sharp turnings towards left and right directions. This project uses AT89S52 as its controller. A high sensitive induction type metal detector is designed using colpitts oscillator principle and fixed to this robot. When the robot is moving on a surface, the system produces a beep sound when metal is detected. The RF modules used here are Transmitter, Receiver, RF Encoder and RF Decoder. The four switches are interfaced to the RF transmitter through RF Encoder. The encoder continuously reads the status of the switches, passes the data to the RF transmitter and it transmits the data. At the receiver end RF decoder takes the data bit wise and moves the robot accordingly.

**Block Diagram:** Transmitter

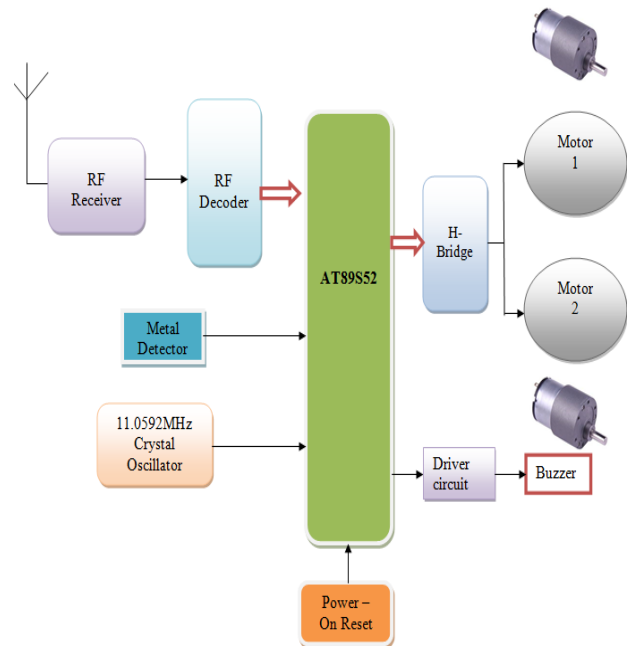
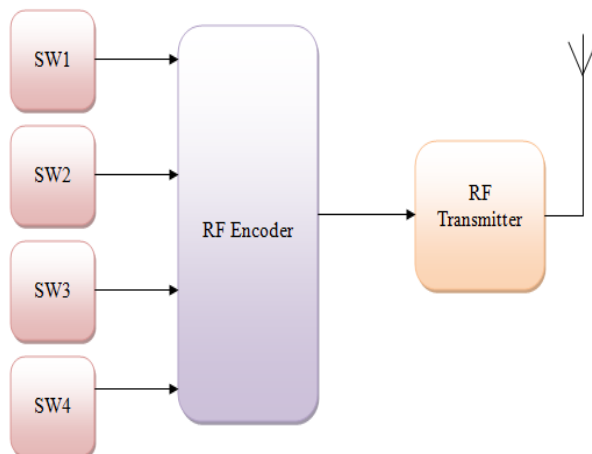

## II. PROPOSED SYSTEM

A metal detecting robot is moving using IoT. This robot can be controlled from a PC/mobile using internet. This can be moved forward and reverse direction using geared motors of 60RPM. Also this robot can take sharp turnings towards left and right directions. An IoT module is interfaced to the controller which receives the commands and moves accordingly. A high sensitive induction type metal detector is designed using colpitts oscillator principle and fixed to this robot. Also a camera is interfaced to the controller. When the robot is moving on a surface, the system produces a beep sound when metal is detected. Simultaneously the things around the robot will be transmitted to remote place. User can monitor the video on PC. The Raspberry Pi is a credit-card-sized single-board computer developed in the UK by the Raspberry Pi Foundation. The Raspberry Pi has a Broadcom system on a chip which includes processor Video Core IV GPU. It does not include a built-in hard disk or solid-state drive, but Uses anSD card for booting and long-term storage. This project uses 12V battery. This project is much useful for mines detection and surveillance applications.

Basic Hardware of Raspberry-PI

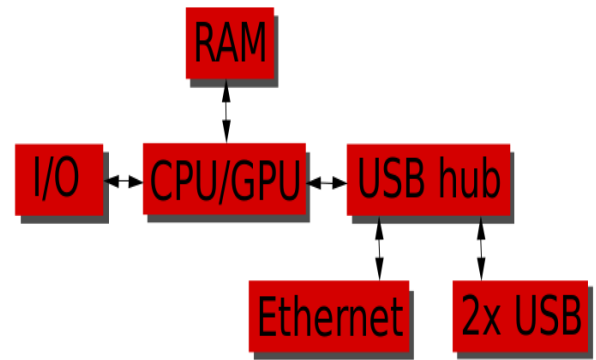
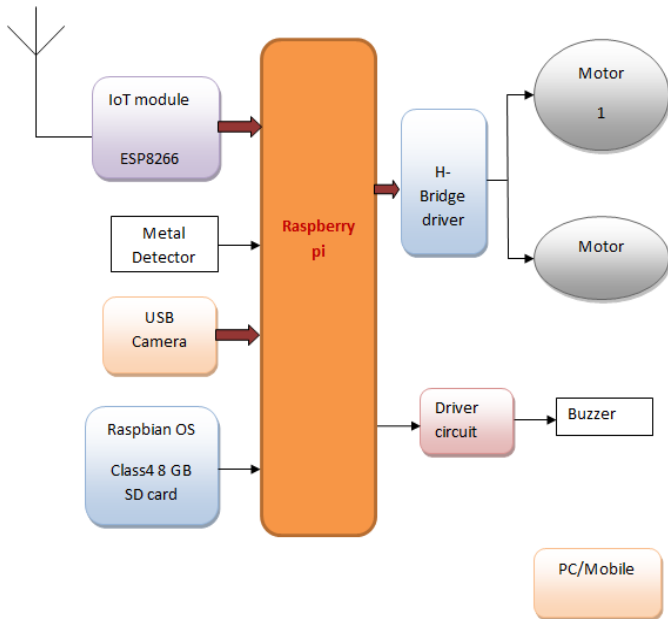

OS used in Raspberry pi is Linux

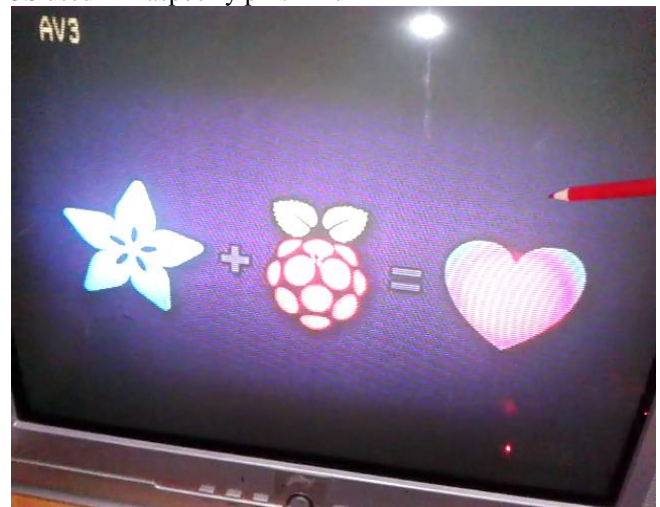

Internet of things  
 Internet is helping people to communicate each other using different applications



RASPBERRY-PI



The Raspberry Pi has a Broadcom system on a chip (SoC).

Features

- System Memory – 1GB LPDDR2
- Storage – micro SD card slot (push release type)
- Video & Audio Output – HDMI and AV via 3.5mm jack.
- Connectivity – 10/100M Ethernet
- USB – 4x USB 2.0 ports, 1x micro USB for power
- Expansion
- 2x20 pin header for GPIOs
- Camera header
- Display header
- Power – 5V via micro USB port.
- Dimensions – 85 x 56 mm

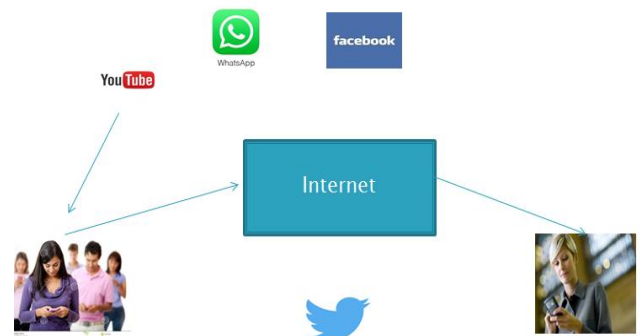

Internet of things helps the things to communicate each other using IoT module  
 ESP8266EX

The Internet of Things (IoT) is the network of physical objects or "things" embedded with electronics, software, sensors, and network connectivity, which enables these objects to collect and exchange data.

Worldwide Internet of Things Revenue Opportunity



Potential growth in worldwide IoT sensor deployments for CRE (2015-20), millions

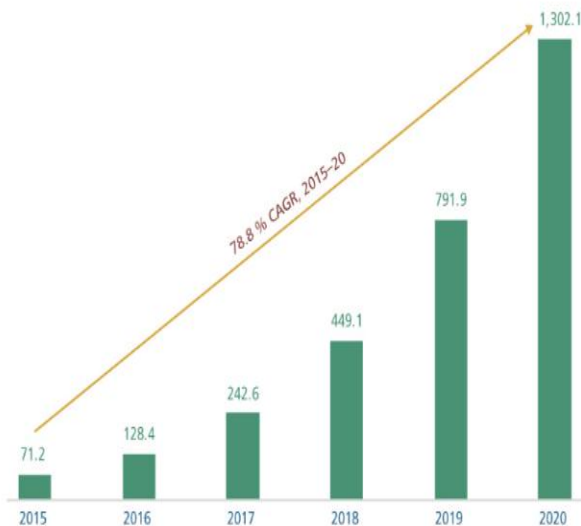

Interfacing diagram

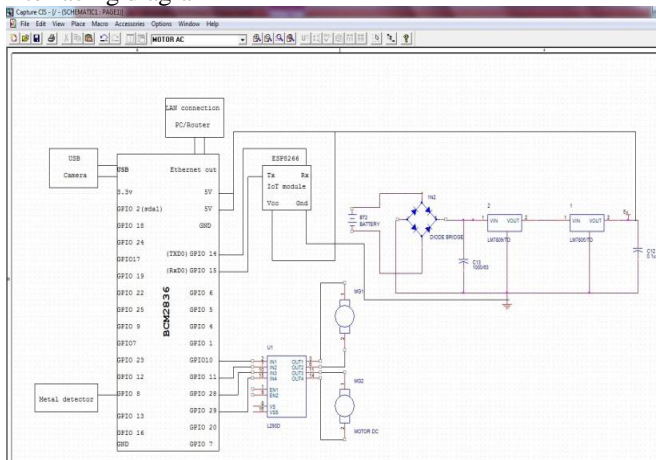

Metal detector

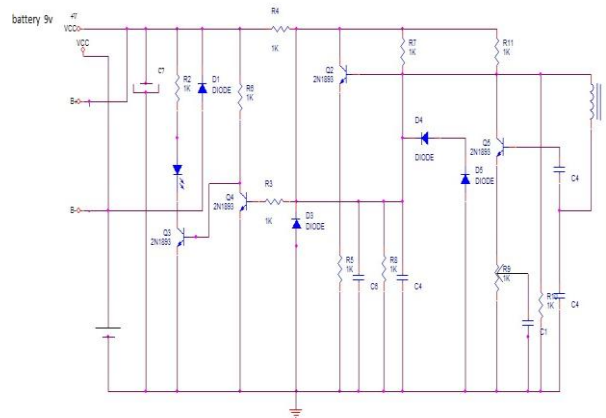

ADVANTAGE

Remote operation

APPLICATIONS

- Industries are using IoT solutions for monitoring, control, process, inventory tracking, data links and bar code reading devices.
- Forests

III. CONCLUSION

This project presents a moving robot with metal detecting and IoT communication and it is designed and implemented with Raspberry pi in embedded system domain. Experimental work has been carried out carefully. The result shows that higher efficiency is indeed achieved using the embedded system. The proposed method is verified to be highly beneficial for the safety purpose.

REFERENCES

- [1] Gross, H.-M., Boehme, H.-J., and Wilhelm T., "Contribution to vision based localization, tracking and navigation methods for an interactive mobile service-robot," In the Proceedings of the IEEE International Conference on Systems, Man, and Cybernetics, pp. 672-677, 2001
- [2] Jeonghye Han, Jaeyeon Lee, and Youngjo Cho, "Evolutionary role model and basic emotions of service robots originated from computers," In the Proceedings of the IEEE International Workshop on Robot and Human Interactive Communication (ROMAN), pp. 30-35, 2005
- [3] Moonzoo Kim, KyoChul Kang, and Hyoungki Lee, "Formal Verification of Robot Movements - a Case Study on Home Service Robot SHR100," In the Proceedings of the IEEE International Conference on Robotics and Automation (ICRA), pp. 4739-4744, 2005
- [4] Bischoff, R., and Graefe, V., "HERMES - a versatile personal robotic assistant," Proceedings of the IEEE, vol. 92, pp. 1759-1779, 2004.
- [5] Dong To Nguyen, Sang-Rok Oh, and Bum-Jae You, "A framework for Internet-based interaction of

- humans, robots, and responsive environments using agent technology,” *IEEE Transactions on Industrial Electronics*, vol. 52, Issue 6, pp. 1521-1529, 2005
- [6] Lenser, S., and Veloso, M., “Sensor resetting localization for poorly modeled mobile robots,” In the Proceedings of the International Conference on Robotics and Automation (ICRA), pp. 1225–1232, 2000.
- [7] Taipalus, T., and Kazuhiro K., “Development of service robot for fetching objects in home environment,” In the Proceedings of the IEEE International Symposium on Computational Intelligence in Robotics and Automation (CIRA), pp. 451-456, 2005
- [8] Yoshikazu K., Takayuki K., Yasuyuki S., Kiyoshi K., and Hiroshi I., “An Approach to Integrating an Interactive Guide Robot with Ubiquitous Sensors,” In the Proceedings of the IEEE/RSJ International Conference on Intelligent Robots and Systems (IROS), pp. 2500-2505, 2004
- [9] YeongChe Fai, Shamsudin H.M. Amin, NorsheilabtFisal, J. Abu Bakar. “Bluetooth Enabled Mobile Robot.” *IEEE ICIT'02*, Bangkok, THAILAND 2002.