

REVIEW OF POWER QUALITY ENHANCEMENT IN WIND ENERGY USING STATCOM DEVICE

Megha Patel¹, Stuti R. Christian²

¹PG Scholar, Electrical Department, LDRP-ITR, Gandhinagar, Gujarat, India

²Assisatnt Professor, Electrical Department, LDRP-ITR, Gandhinagar, Gujarat, India

Abstract: *Injection of the wind power into an electric grid affects the power quality. The performance of the wind turbine and thereby power quality are determined on the basis of measurements and the norms followed according to the guideline specified in International Electro-technical Commission standard, IEC-61400. The influence of the wind turbine in the grid system concerning the power quality measurements are-the active power, reactive power, variation of voltage, flicker, harmonics, and electrical behaviour of switching operation and these are measured according to national/international guidelines. The paper study demonstrates the power quality problem due to installation of wind turbine with the grid. In this proposed scheme STATIC Compensator (STATCOM) is connected to mitigate the power quality issues. The battery energy storage is integrated to sustain the real power source under fluctuating wind power. The STATCOM control scheme for the grid connected wind energy generation system for power quality improvement is simulated using MATLAB/SIMULINK in power system block set. The effectiveness of the proposed scheme relives the main supply source from the reactive power demand of the load and the induction generator. The development of the grid co-ordination rule and the scheme for improvement in power quality norms as per IEC-standard on the grid has been presented*

I. INTRODUCTION

A rapid development of wind power generation has been seen in a global scale. As with increasing the size of wind turbines and wind farms, a large amount of wind power is injected to the power system. Due to random nature of wind energy a huge penetration of power may cause important problems and also affect the characteristics of the wind generators. The consolidation of wind energy into present existing power system creates technical challenges, which require consideration of stability, voltage regulation related power quality problems.

The power quality problems can be seen in accordance to wind generation, transmission and distribution system, such as voltage sag, flickers, voltage swells, harmonics etc. Due to change in voltage, flicker and harmonics failure of devices like microprocessor based controller, programmable logic controller (PLC), variable speed drives, light source flickering and screen occurs [1]. It also may cause to tripping of contactor, failure of protection device, sensitive equipments stoppage like computers, programmable logic control (PLC) system and also may halt the process or even

may damage of some sensitive equipments. In transmission and distribution system power quality of supply is very importance measure to be considered. So considering in wind generation system this power quality issues become so much important measure. As the technology developing in the power generation field the wind power generation developing very quickly. To reduce the disturbances produced by variation in wind flow [2], we use induction generator and connect it directly to the grid system. This induction generator is simple and robust in construction and having reactive power for excitation. However, in induction generators to produce magnetization the reactive power support is required.

The major drawback in induction generators is active, reactive power and the terminal voltage varies due to fluctuating wind. A sophisticated control scheme requires in wind generation system when operating normally making proper control of active power production. The new technology in wind generation system use STATCOM based control scheme for improvement of the quality of power. Additionally the wind flow is unpredictable in nature so if there is some disturbance occurs the battery energy storage systems (BESS) mitigate the fluctuation of power into the system.

II. POWER QUALITY

As per the standard directory of IEEE for electrical and electronics power Quality means “the concept of powering and grounding sensitive electronic equipment in a manner that is suitable to the operation of the equipment”. It can also be described as the “the measure, analysis & improvement of bus voltage mostly load bus voltage, to maintain that voltage to be a sinusoidal at rated voltage and frequency”

The definition of perfect power quality can be given as the waveform of voltage is continuous and purely sinusoidal having a constant frequency and fixed amplitude. It can also be expressed in terms of electrical property and physical characteristics. The most often term to describe power quality is voltage, frequency and interruptions. The voltage quality must fulfil all the requirements specified in national and international standards. In such standards, the voltage disturbances are further classified into voltage variations, transients, flicker and harmonic distortion. Fig. 2.1 shows a classification of different power quality phenomena.

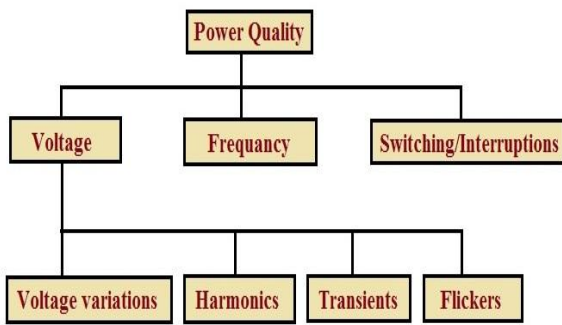

Fig. 2.1 Power Quality Phenomena

The studies of power quality are important in wind turbine system as an individual unit of certain power level. The advancement in power electronic devices with fast switching makes a trend for reducing the size of power supply. The dark side of such fast switching device is that it produces current distortion. The rapid increase of these electronic controllers in our everyday life increases the distortion level into the line. So as harmonics current increases in the system with increased reactive power demand, this produces adverse effect on some of delectated devices. The increase load demand cannot just fulfil by increasing the power generation due to various adverse effect on environment, the increased fuel cost, etc. So that the rapid growth in power generation is not possible so the existing system burden increases and results in poor power quality.

Power Quality Issues

Power quality describes the current, voltage and frequency within the power system. Most of the power system equipment has been enough capable to run successfully with relatively wide range variation of the considered three parameters i.e. voltage, frequency and interruption, so the power quality term did not so critically meant prior to last decade. However within last decade of time the large numbers of electrical equipments (computers, microprocessors, power system equipments like as the adjustable speed drives) have been added to the power system which is not so much tolerant in nature of power quality.

The sophistication of these electrical equipment's boosted with the development of the electronics enforced the requirement of quality power at the consumer utility. Because of these situation, to ensure the availability of the uninterrupted and quality power become too competitive for the power producer. The deregulation of the power system also boosted because of this situation with the main aim of delivery of system power at all location with quality.

Surge

Surge is unnecessary voltage decay with respect to time. It can also call the transients into the system. The portion of the change in a variable which disappears during change over from one steady state operating situation to other situation called the transients.

Impulsive and Oscillatory are the further classification of the Transients.

(1) Oscillatory transients

Nature wise this surge or transients oscillatory. It shows a damped oscillation with the range of frequency between few hundred hertz to several megahertz. Causes of the oscillatory transient are energizing of capacitor bank, energizing of transmission line etc.

(2) Impulsive transients

A sudden change in the steady state condition of current, voltage or both current and voltage defied as the impulsive transient. Its polarity is unidirectional, either positive or negative.

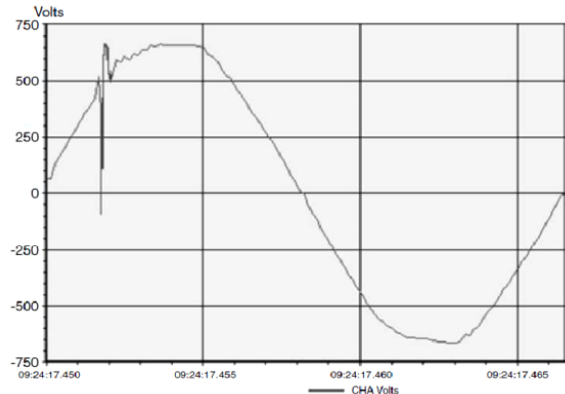

Fig. 2.2- Transients due to motor starting

(3) Transient due to motor starting

Impulsive transients are analyzed by their rise times and decay times. The resistive circuit elements damp the impulsive transients quickly so they cannot propagate more distance from their source. Hence their effects are localized.

(4) Long duration voltage variations

When the time duration of voltage (in RMS) deviation at supply freq. is more than 1 minute then it defined as the long duration voltage variations. The voltage can be less than 0.9p.u or more than 1.1p.u.

Main cause of over voltage is energizing a capacitor bank or switching off a load. Under voltage are resulted due to the reverse actions which causes the over voltage.

(5) Sustained interruptions

If the supply voltage becomes zero for more than one minute, it can be defined as the sustained interruption.

True impact of the power interruption does not carried out by the sustained interruption but even half a cycle can be harmful for s sensitive load.

Harmonics

The non-linear loads such as variable speed drives, electric arc furnaces, large concentrations of arc discharge lamps, distorted line current and saturation of magnetization of transformer are major cause of harmonics distortion. Such load generates current which affect the system impedance and raise the harmonics current. This harmonics current increase power system losses, power quality degradation and noise in communication system. So that the current harmonics should be within limit at the point of wind turbine connected with rest of the system.

The harmonics are characterized by the supply waveform other than fundamental waveform. Mostly the waveform is

defined in periodic sequence and such periodic waves can be solve by Fourier series and the harmonics part of waves is in integer multiple of fundamental frequency wave. This integer factor is order of harmonic component in the fundamental wave. Let's 'n' be the order of harmonics, then n will be 1, 2, 3...etc.

Here the order of current harmonics can be expressed as

$$I_n = I_n \sin 2\pi nft$$

Where, I_n is the harmonics amplitude of n^{th} order

The integer harmonics can further categorized into two parts

- Odd harmonics component
- Even harmonics component

This integer harmonics are further categorized into sub harmonics and inter harmonics

Odd Harmonics

The inter harmonics waveform containing odd multiple integer of fundamental waveform is called odd harmonics. It can be expressed as

$$I_n = I_n \sin 2\pi nft \quad \text{Where } n = 3, 5, 7, \text{ etc and}$$

I_n is the amplitude of harmonic component of order 'n'.

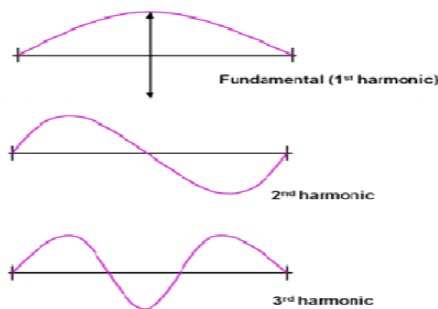

Fig 2.3 - Harmonics

Even Harmonics

The inter harmonics waveform containing even multiple integer of fundamental waveform is called even harmonics. Even harmonics may be expressed as

$$I_n = I_n \sin 2\pi nft$$

Where, $n = 2, 4, 6, \dots$ etc. and I_n is the amplitude of harmonic component of order 'n'.

Inter Harmonics: The harmonics wave having frequency little bit greater than the fundamental wave but not integral multiple of fundamental frequency is known as inter harmonics.

Sub Harmonic: The harmonics waveforms which have frequency level lesser than fundamental frequency is known as sub harmonics.

The measurement of harmonics content at the point of wind turbine is problematic due to already existence of harmonics voltage in grid. The waveform of the grid voltage is generally not sinusoidal type. The harmonics voltages always be there in grid as an integer harmonics value of 5th and 7th order which affects the measurement procedure. Now days variable speed type turbines are equipped with self commutated type PWM inverter system. The advantage of such system is that it can control both active and reactive power, but at another side it also produced a harmonic

current contain. So the total harmonic voltage distortion in line is given as,

$$V_{THD} = \sqrt{\sum_{h=2}^{40} \frac{V_h^2}{V_1^2}} 100$$

Where, $V_h - h_{\text{th}}$ – harmonic voltage; and V_1 – fundamental frequency 50 Hz, The THD limit for various level of system voltages are given in the table 2.1

Table 2.1. Voltage Harmonics Limit

System Voltage (kV)	Total Harmonic Distortion (%)
400	2.0
220	2.5
132	3.0

THD of current I_{THD} is give as,

$$I_{THD} = \sqrt{\sum_{h=2}^{40} \frac{I_h^2}{I_1^2}} 100$$

Where, $I_h - h_{\text{th}}$ harmonic current and I_1 –fundamental frequency (50) Hz, The acceptable level of THD in the current is given in table 2.2

Table 2.2 Current Harmonic Limit

Voltage level	66kV	132kV
I_{THD}	5.0	2.0

Various standards of harmonic level are also proposed for utility system and individual consumer for helping to design the utility system to improve the power quality. The load characteristics and level of power system significantly determine the harmonics effects. For deciding the standard level of harmonics, the IEEE standards are followed in most of the countries. The recommended practice helps designer to limit voltage and current distortion within acceptable limits at point of common coupling (PCC) between consumer and supply system.

III. DFIG

DOUBLY-FED ELECTRIC MACHINE

Doubly-fed electric machines are electric motors or electric generators that have windings on both stationary and rotating parts, where both windings transfer significant power between shaft and electrical system. Doubly-fed machines are useful in applications that require varying speed of the machine's shaft for a fixed power system frequency.

Classification

Electric machines are either Singly-Fed with one winding set that actively participates in the energy conversion process or Doubly-Fed with two active winding sets. The wound-rotor induction machine and the field-excited synchronous machine are singly-fed machines because only one winding set actively participates in the energy conversion process. Examples of doubly-fed electric machines are the wound-rotor doubly-fed electric machine, the brushless wound-rotor doubly-fed electric machine, and the brushless doubly-fed

induction electric machines.

Features of doubly fed machines

The wound-rotor doubly-fed electric machine is the only electric machine that operates with rated torque to twice synchronous speed for a given frequency of excitation (i.e., 7200 rpm @ 60 Hz and one pole-pair versus 3600 rpm for singly-fed electric machines). Higher speed with a given frequency of excitation gives lower cost, higher efficiency, and higher power density. In concept, any electric machine can be converted to a wound-rotor doubly-fed electric motor or generator by changing the rotor assembly to a multiphase wound rotor assembly of equal stator winding set rating.

If the rotor winding set can transfer power to the electrical system, the conversion result is a wound-rotor doubly-fed electric motor or generator with twice the speed and power as the original singly-fed electric machine. The resulting dualported transformer circuit topology allows very high torque current without core saturation, all by electronically controlling half or less of the total motor power for full variable speed control.

In practice, the classical wound-rotor doubly-fed "induction" electric motor or generator system has known issues of instability, high maintenance and inefficiency of an integral multiphase slip-ring assembly, and discontinuity about synchronous speed where induction ceases to exist. A practical wound-rotor doubly-fed electric machine system that does not rely exclusively on asynchronous (i.e., induction) principles while symmetrically motoring or generating over its entire speed range has never materialized from the electric machine establishment, despite years of research to find an evolutionary brushless, synchronous, and stable control technology.

Like wound rotor synchronous machines, the magnetic flux can be produced by the stator current, rotor current or by the combination of the both. For example, if all magnetizing current is supplied by the rotor windings, the stator will only have torque current and so unity power factor. At synchronous speed the rotor current has to be DC, as in ordinary synchronous machines. If the shaft speed is above or below synchronous speed, the rotor current must be AC at the slip frequency. Reactive power is used in the rotor winding when it is used to magnetize the machine in non-synchronous operation. Rotor current is also needed to produce torque in addition to magnetization. Thus active power is present in the rotor in addition to reactive power.

Double fed induction GENERATOR (dfig):-

DFIG is an abbreviation for Double Fed Induction Generator, a generating principle widely used in wind turbines. It is based on an induction generator with a multiphase wound rotor and a multiphase slip ring assembly with brushes for access to the rotor windings. It is possible to avoid the multiphase slip ring assembly (see brushless doubly-fed electric machines), but there are problems with efficiency, cost and size. A better alternative is a brushless wound-rotor doubly-fed electric machine.

Principle of a Double Fed Induction Generator connected to a wind turbine

The principle of the DFIG is that rotor windings are

connected to the grid via slip rings and back-to-back voltage source converter that controls both the rotor and the grid currents. Thus rotor frequency can freely differ from the grid frequency (50 or 60 Hz). By using the converter to control the rotor currents, it is possible to adjust the active and reactive power fed to the grid from the stator independently of the generator's turning speed. The control principle used is either the two-axis current vector control or direct torque control (DTC). DTC has turned out to have better stability than current vector control especially when high reactive currents are required from the generator.

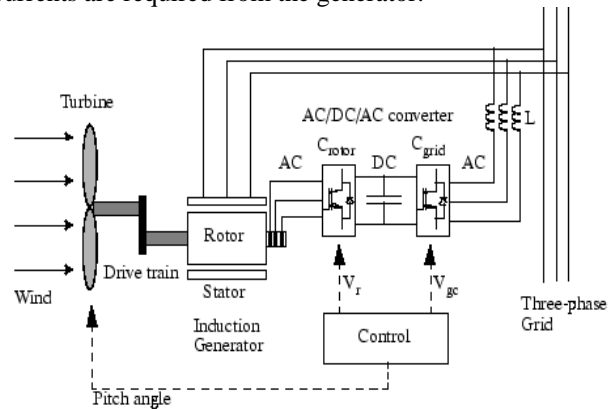

Fig-Operating Principle of the Wind Turbine Doubly-Fed Induction Generator

The doubly-fed generator rotors are typically wound with 2 to 3 times the number of turns of the stator. This means that the rotor voltages will be higher and currents respectively lower. Thus in the typical $\pm 30\%$ operational speed range around the synchronous speed, the rated current of the converter is accordingly lower which leads to a lower cost of the converter. The drawback is that controlled operation outside the operational speed range is impossible because of the higher than rated rotor voltage.

Further, the voltage transients due to the grid disturbances (three- and two-phase voltage dips, especially) will also be magnified. In order to prevent high rotor voltages - and high currents resulting from these voltages - from destroying the IGBTs and diodes of the converter, a protection circuit (called crowbar) is used. The crowbar will short-circuit the rotor windings through a small resistance when excessive currents or voltages are detected. In order to be able to continue the operation as quickly as possible an active crowbar has to be used. The active crowbar can remove the rotor short in a controlled way and thus the rotor side converter can be started only after 20-60 ms from the start of the grid disturbance. Thus it is possible to generate reactive current to the grid during the rest of the voltage dip and in this way help the grid to recover from the fault.

IV. SIMULATION AND RESULTS

Introduction

The proposed system in this dissertation work contains a wind generating system combined with the transmission line and the source for proper grid integration. The 3-phase system proposed is integrated with the load and the circuit

breaker for protection purpose also. The output voltage, current and the output Active & reactive power results shown in the below sections.

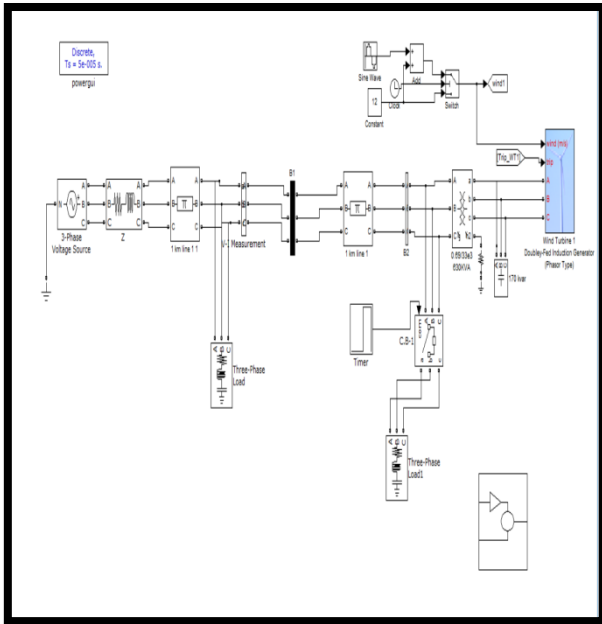

Fig 5.1- Single DFIG based Wind Power Plant

System Parameters

- DFIG Voltage: - 3-phase, 690 V, 60 Hz
- Pitch angle: - 45 degree , $K_p = 5, K_i = 25$
- Wind Based speed: - 9 m/s
- 1 km Transmission Line Data: - Resistance - 0.1115 Ohm/km (R1)
- 0.413 Ohm/km (R0)
- Inductance- 1.05e-3 H/km (L1)
- 3.2e-3 H/km (L0)
- Capacitance- 11.33e-009 F/km (C1)
- 5.01e-009 F/km (C0)

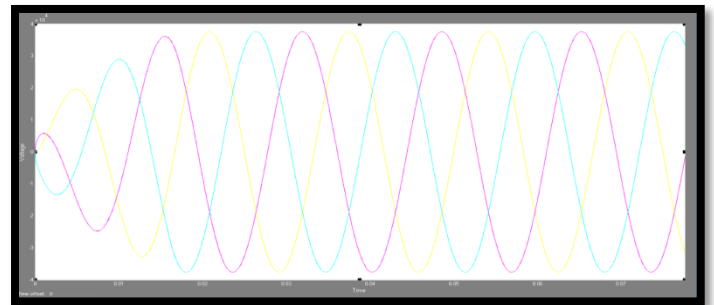

Fig 5.3- Voltage at Bus-1 in wind Power Plant

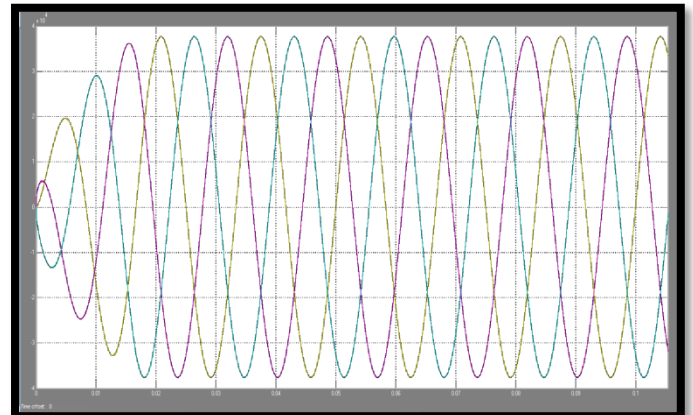

Fig 5.4- Voltage fluctuation at Bus-2 in wind Power Plant

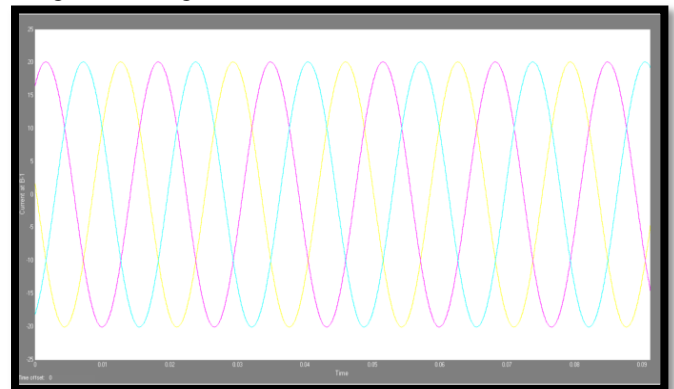

Fig 5.5- Current at B-1

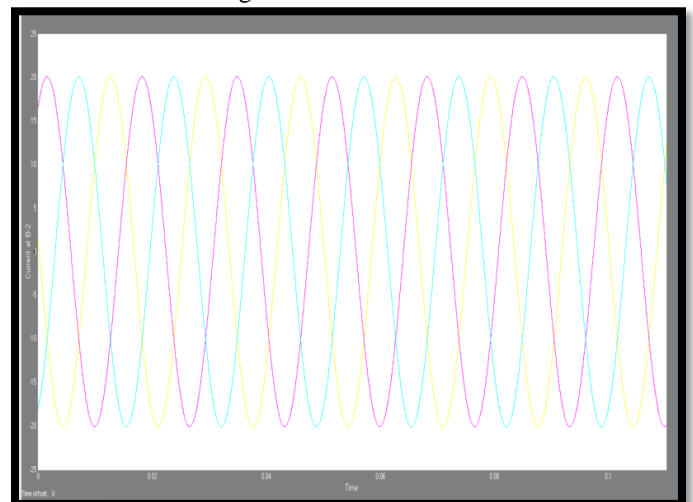

Fig 5.6- Current at B-2

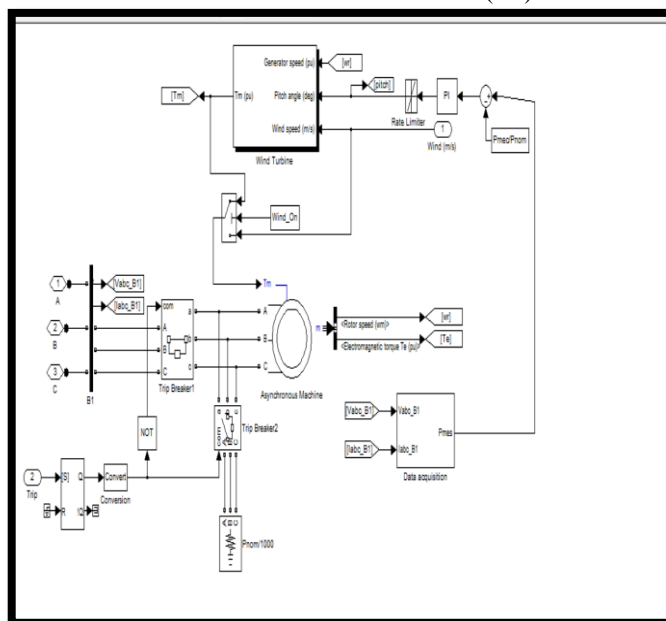

Fig 5.2- Subsystem of DFIG

Proposed System with fault condition:-

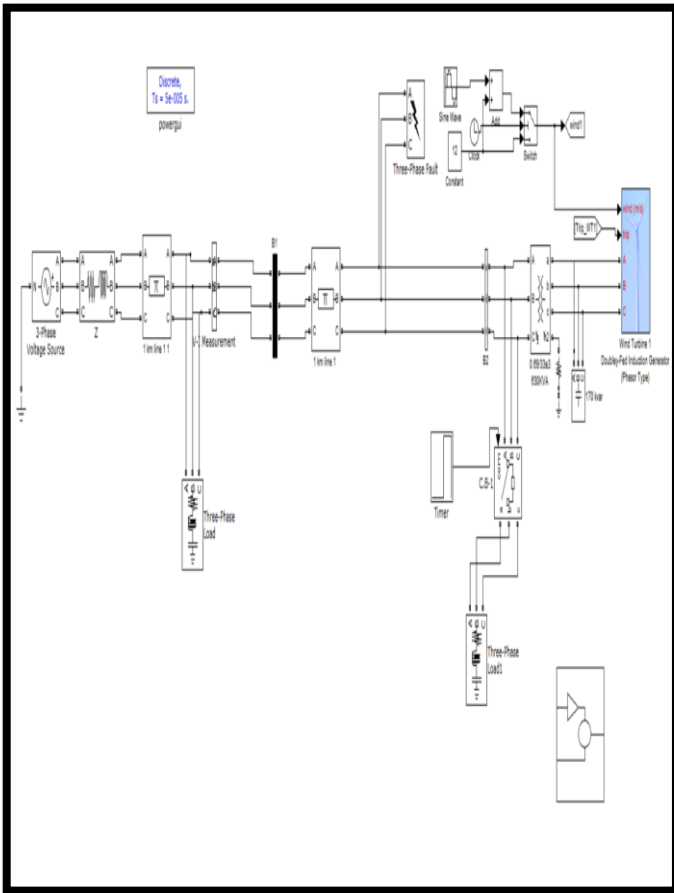

Fig 5.7- Proposed Matlab model with fault condition

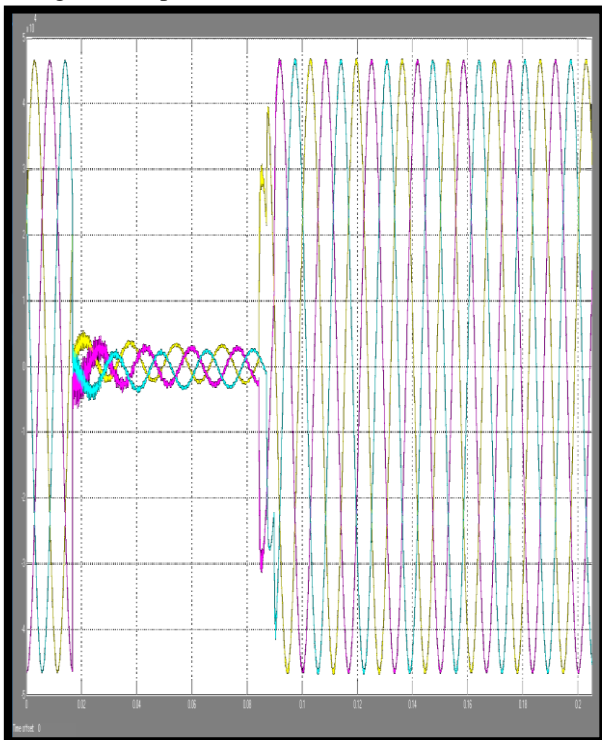

Fig 5.8- Voltage at B-1 during fault condition

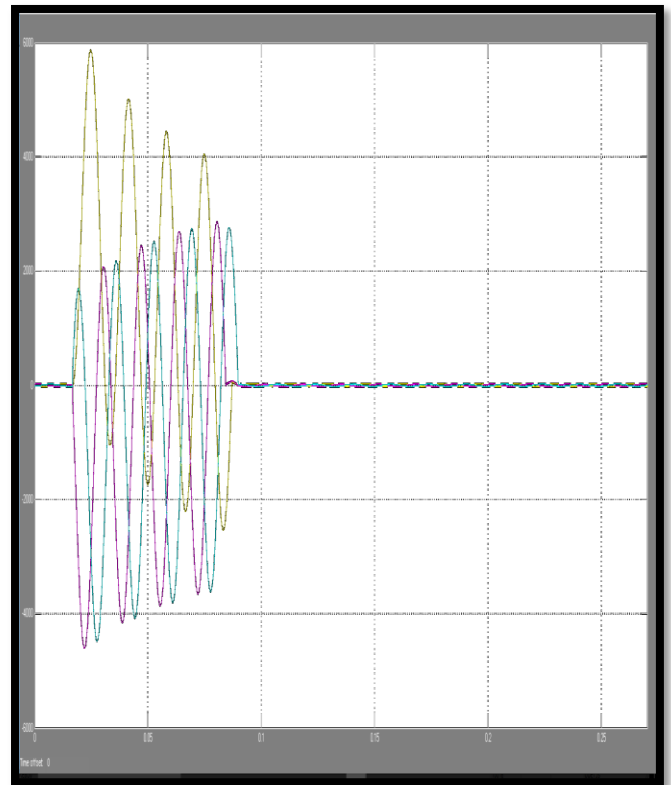

Fig 5.9 Current at B-1 during fault condition

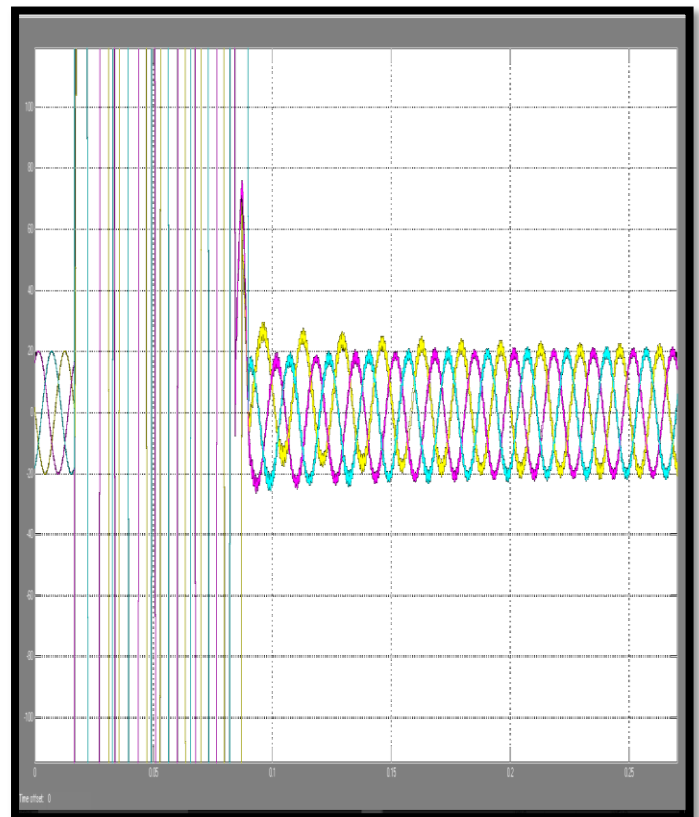

Fig 5.10 Current at B-1 during fault condition with Zoom Scale

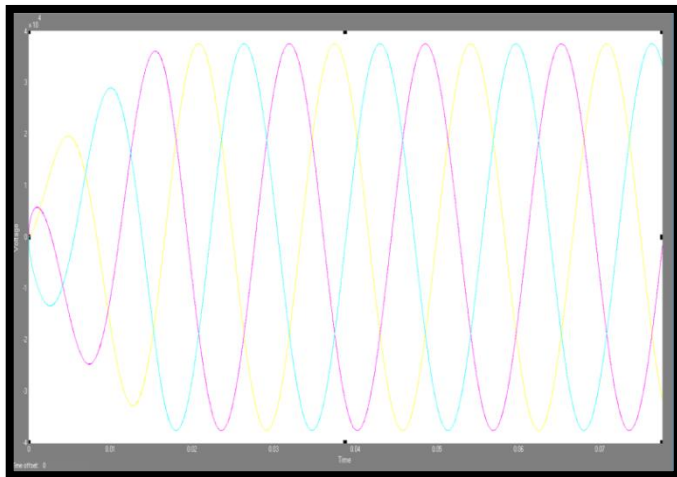

Fig 5.11- Voltage at B-2 during fault condition

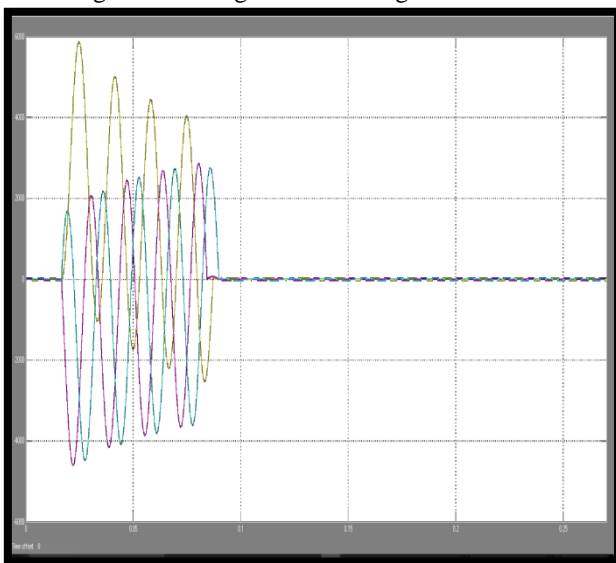

Fig 5.12 Current at B-2 during fault condition

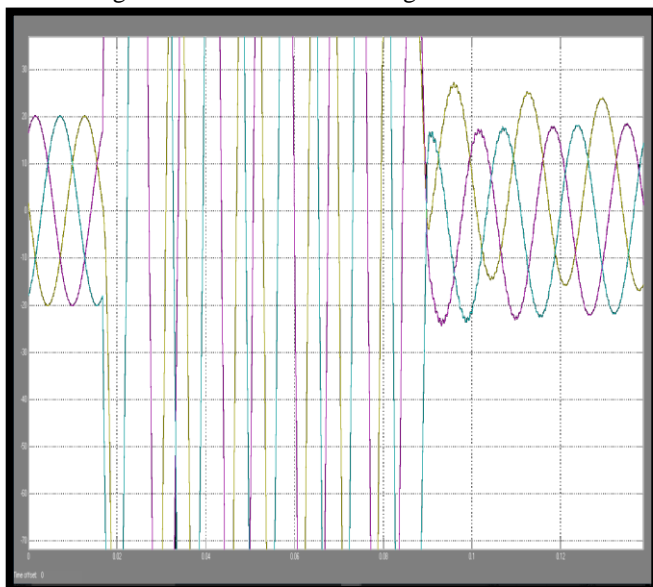

Fig 5.13 Current at B-2 during fault condition with Zoom Scale

V. CONCLUSION

Various parts of this project has been showed and discussed with precision and proper details. Also it shows that change in load has significant effect on power system voltage and current. Change in load can produce some of power quality problems which are undesirable but it is due to distribution network and totally depending on power consumers. So the harmonics production due to load change can't be avoid but it can reduce by using prescribed system. We also create fault and shows the disturbance and power quality problems in the proposed system. Also one major part of this paper work is excess power of wind generation can store using high capacity batteries so that the power exchange with grid can be constant and the energy can be utilize during pike load time. This gives power saving of base load plant and provide a non polluting power time to time. Thus the concept is another step in the field of non polluting energy and reduction in carbon footprint.

REFERENCES

- [1] Mohammad Ali Tofigh and Nasrudin Abd Rahim, "Voltage Regulation of Grid Connected Wind Farm Using STATCOM", IEEE SYSTEMS JOURNAL, VOL. 4, NO. 3.
- [2] Sharad W. Mohod and Mohan V. Aware, "A STATCOM-Control Scheme for Grid Connected Wind Energy System for Power Quality Improvement", IEEE SYSTEMS JOURNAL, VOL. 4, NO. 3, SEPTEMBER 2010.
- [3] V. Amarnath Reddy, P. Harshavardhan Reddy, M. Sudheer babu, " Power Quality Improvement in Wind Energy system by using STATCOM on Integration to the Grid", Vol. 2, Issue. 5, Sep.-Oct. 2012 pp-3637-3640 ISSN: 2249-6645 , International Journal of Modern Engineering Research (IJMER).
- [4] Chandulal Tejavoth, M. Trishulapani, V.K.R.Mohan Rao, Y.Rambabu, " Power Quality Improvement for Grid Connected Wind Energy System using STATCOM-Control Scheme", IOSR Journal of Engineering (IOSRJEN) e-ISSN: 2250-3021, Vol. 3, Issue 7 (July. 2013).
- [5] Sharad W. Mohod and Mohan V. Aware, "Power quality issues and its improvement in wind energy generation interface to grid system", MIT International Journal of Electrical and Instrumentation Engineering, Vol-1, No-2, August-2011.
- [6] Deshveer1, Amit Bhardwaj2 "Simulation and Modeling of STATCOM and WINDFARM in Transmission Line Using MATLAB and Analysis of Bus Voltage", International Journal of All Research Education and Scientific Methods (IJARESM).
- [7] Chad Abbey, Kai Strunz, and G'eza Jo'os "A Knowledge Based Approach for Control of Two-Level Energy Storage for Wind Energy Systems", IEEE TRANSACTIONS ON ENERGY CONVERSION, VOL. 24, NO. 2, JUNE 2009.

- [8] M.Laouera, A.Mekkaouia, M.Younes, "STATCOM and Capacitor Banks in a fixed-speed wind farm", Science Direct, 1876-6102 , 2014 Elsevier Ltd.
- [9] Christian Wessels, Nils Hoffmann, Marta Molinas and Friedrich Wilhelm Fuchs, "STATCOM Control at Wind Farms With Fixed-Speed Induction Generators Under Asymmetrical Grid Faults", IEEE TRANSACTIONS ON INDUSTRIAL ELECTRONICS, VOL. 60, NO. 7, JULY 2013.
- [10] Sarika D. Patil , "Improvement of Power Quality Considering Voltage Stability in Grid Connected System by FACTS Devices ,"Dept. of Electrical Engineering, Rajiv Gandhi College of Engineering & Research, Nagpur, India.
- [11] Mr.Saurabh S. Kulkarni* Mr. Naveen Kumar Mucha," A Matlab/Simulink Model for the control scheme utilized to improve power quality of Wind Generation System connected to Grid" , International Journal of Innovative Research in Advanced Engineering (IJIRAE) ISSN: 2349-2163 Volume 1 Issue 6 (July 2014).