

ENHANCING EFFICIENCY OF HYBRID PV WIND BATTERY SYSTEM USING P&O ALGORITHM

Rahul¹, Joginder Singh²
Department of Electrical Engineering,
Ganga Institute of Technology and Management, Jhajjar, India

The functioning power of PV array depends on the solar temperature, radiation and particularly the photovoltaic array output voltage. If the transferable of power between photovoltaic panel and battery load is not optimum, the entire efficacy of the photovoltaic structure will be suffered harmfully. Numerous publications challenge the problem regarding the search of the optimum working point by utilizing various MPPT approaches in order to excerpt the supreme energy from the photovoltaic panel. The mainstream of these initial approaches are based on so-named hill climbing method. These approaches can be utilized to regulate the peak power point for identified solar temperature and radiation situations; though they exhibit oscillatory actions around the peak power point under normal working conditions. Furthermore, they can lead to a wrong path of the peak power point tracing (i.e. to smaller amount efficiency) in the case of an abrupt difference of irradiance and/or temperature when the scheme is already very close its real peak power point. This is for the reason that the hybrid Algorithm procedure interprets the perturbation& Observation (P&O) as the consequence of its previous difference of the modules working voltage, and guesses its next deviation to be in the similar path as that of the earlier one. In furthermost of the maximum peak power point tracking approaches described presently in the literature, the finest function point of the photovoltaic schemes is assessed by linear calculations. Nevertheless these estimates can lead to less than optimum functioning conditions and henceforth decrease significantly the performances of the photovoltaic scheme. This thesis presents a novel technique to determine the peak power point based on observes of the open circuit voltage of the photovoltaic cells, and a nonlinear expression for the optimum functioning voltage is established based on this open circuit voltage. The methodology is thus a mixture of the nonlinear and enhanced Hybrid power point tracking algorithm. The simulation and experimental consequences show that the method develops clearly the tracing efficiency of the extreme power obtainable at the production of the photovoltaic array. The new technique decreases the fluctuations around the peak power point, and raises the average efficiency of the maximum power point tracking attained. The novel maximum power tracking technique will provide additional power to energy storage.

Key Area: PV Cell, Hybrid power point tracking algorithm, MATLAB Simulink

I. INTRODUCTION

Photovoltaic (PV) is the name of a method of converting solar energy into direct current electricity using semiconducting materials that exhibit the photovoltaic effect, a phenomenon commonly studied in physics, photochemistry and electrochemistry. A photovoltaic system employs solar panels composed of a number of solar cells to supply usable solar power. The process is both physical and chemical in nature, as the first step involves the photoelectric effect from which a second electrochemical process take place involving crystallized atoms being ionized in a series, generating an electric current. Power generation from solar PV has long been seen as a clean sustainable energy technology which draws upon the planet's most plentiful and widely distributed renewable energy source the sun. A photovoltaic energy system is mainly powered by solar energy. The configuration of PV system is shown in figure 1.

It contains PV modules or arrays, which convert solar energy in the form of solar irradiation into electric energy. The dc-dc converter changes the level of the voltage to match it with the electrical appliances that are supplied by this system.

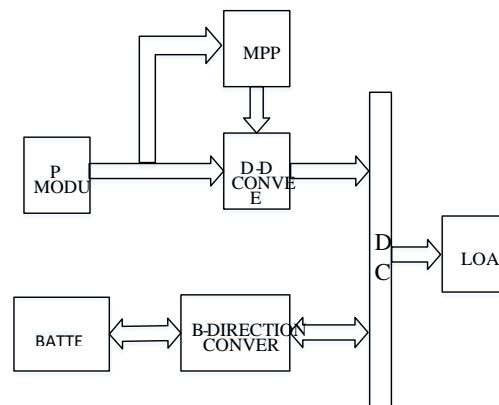

Figure. 1. Overall block diagram of PV energy system

This DC-DC converter may be either buck or boost or buck-boost contingent on the required and available voltage levels. The maximum power point tracing system coerces the maximum power from the PV modules. A bi-directional converter which is able to supply the current in both the directions is used to charge the battery when there is a power surplus and the energy stored by the battery is discharged into the load when there is a power deficit.

Generally a wind turbine consists of a set of rotor blades rotating around a hub, a gearbox-generator set placed inside the nacelle. The basic components of a wind turbine system

are shown in figure 2.

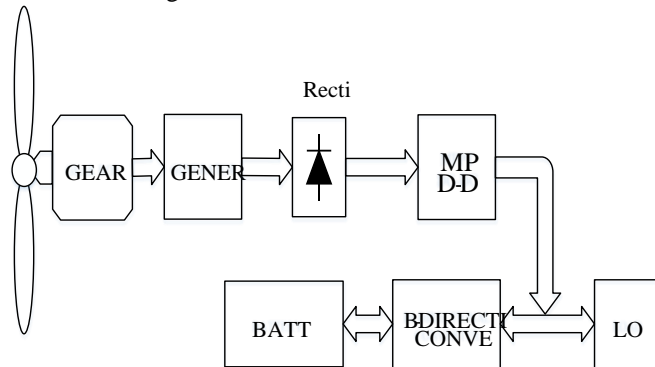

Figure. 2 Overall Block diagram of wind energy system
 Battery is a storage device which stores the excess power generated and uses it to supply the load in addition to the generators when power is required. Both PV and wind energy systems (described in the previous chapters) are integrated i.e. connected to a common DC bus of constant voltage and the battery bank is also connected to the DC bus. Any power transfer whether from generator to battery bank or generator to load or from the battery bank to the load takes place via this constant voltage DC bus. As the power flow associated with the battery is not uni-directional, a bidirectional converter is needed to charge and/or discharge the battery in case of excess and/or deficit of power respectively.

II. SYSTEM CONFIGURATION

System configuration of the proposed hybrid energy can be considered as a complete eco-friendly power generation system because the chief energy source and storage system are all environment friendly. When there is additional solar generation available, the electrolyzer is activated to produce hydrogen, which is then delivered to the hydrogen storage tanks. If the H₂ storage tanks become full, the excess power will be diverted to the dump load. When there is a shortage in PV power generation, the Fuel cell stack will begin to produce power using hydrogen from the reservoir tanks. Different energy sources are connected to the AC bus through appropriate power electronic interfacing circuits.

III. SYSTEM COMPONENT CHARACTERISTICS

To design an overall power management strategy for the system and to examine the system performance, dynamic models for the main components in the proposed hybrid energy system have been developed using MATLAB/Simulink.

A. Photovoltaic

PV effect is a simple physical process through which solar energy is converted directly into electrical energy. The physics of a solar cell, is similar to the p-n junction diode. In a PV array higher the irradiance, the higher are the short-circuit current (I_{sc}) and the open-circuit voltage (V_{oc}). As a result, the larger will be the output PV power. Temperature plays a vital role in the PV performance. It is noted that lower the temperature, the greater is the maximum power and higher the open circuit voltage.

B. Fuel Cell

The PEMFC model is operated under continuous channel pressure with uncontrolled input fuel flow into the Fuel cell. The FC will adjust the input fuel flow according to its load current to maintain the channel pressure constant. The characteristic curve can be divided into three areas. The voltage drop across the Fuel cell related with low currents is because of the activation loss inside the Fuel cell; the voltage drop in the middle of the curve is due to the ohmic loss in the FC stack; and as a result of the concentration loss, the output voltage at the end of the curve will drop suddenly as the load current rises.

C. Electrolyzer

An electrolyzer is a device that yields hydrogen and oxygen from water. In divergence to the electro chemical reaction occurring in an FC to produce electricity, an electrolyzer converts electrical energy into chemical energy stored in hydrogen. For a given electrolyzer, within its rating range, the higher the dc voltage applied, the greater is the load current. So, by applying a higher dc voltage, more H₂ can be generated.

IV. PROPOSED WORK

The economic analysis and environmental impacts of integrating a photovoltaic (PV) array and diesel-fuel power systems for smart villages. MATLAB Simulink is used to match the load with the demand and apportion the electrical production between the PV Wind and Battery system. The economic part of the model calculates the fuel consumed, the kilo watt hours obtained per gallon of fuel supplied, and the total cost of fuel. The block diagram of proposed system is shown in figure 3.

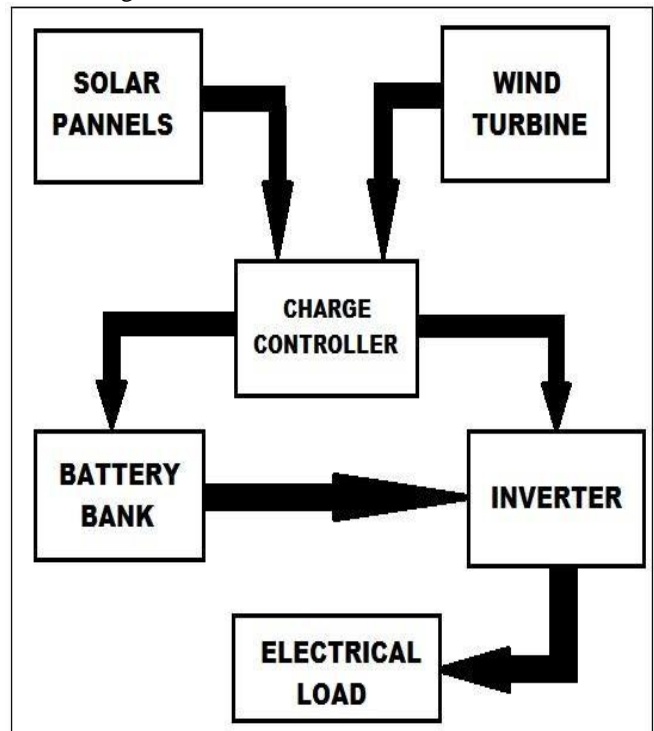

Figure 3. Block diagram of Hybrid energy generation system

V. PROPOSED METHODOLOGY

We have looked at the following technologies, ie small wind turbines, solar PV systems (PVS), batteries and diesel generators to support smart villages. In the hybrid system, the electric demand of the laboratory is coupled to AC, the diesel generator is connected to the AC power of the grid and the solar panel, wind turbine and batteries are connected to both sides of the DC. The conventional diesel generator (DG) is used to supplement the renewable energy system for peak loads and during periods of weak neutral system resources.

VI. SIMULATION & RESULT

Smart Villages are the need of the hour as development is needed for both rural and urban areas for better livelihood and technology will offer effective solution. The technological support already exists at the urban side and there is a tremendous pressure on urban landscapes due to migration of rural people for livelihood. Smart Villages will not only reduce this migration but also irrigate the population flow from urban to rural area as well.

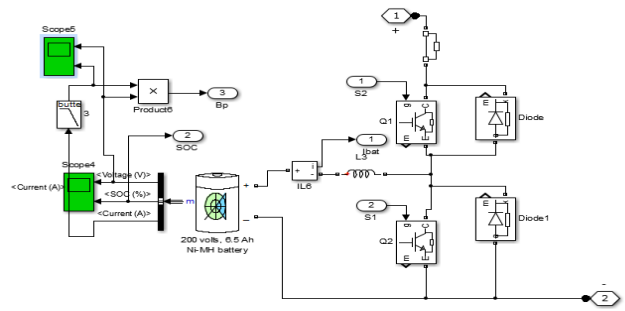

Figure 7. PV system connected with Battery and DC-DC converter

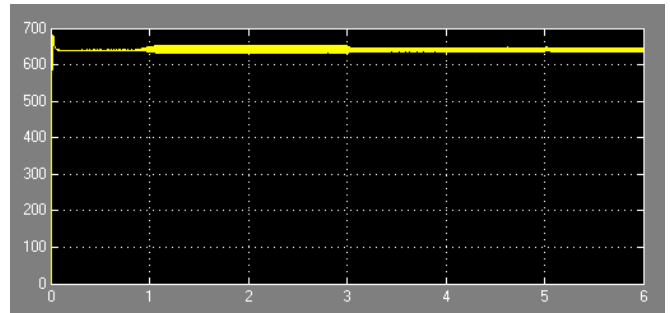

Figure 8. DC Voltage of hybrid PV Wind System

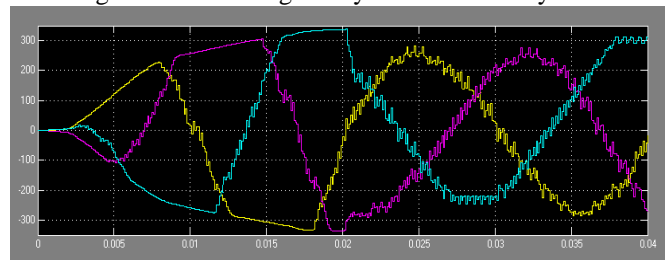

Figure 9. AC Voltage output of Inverter

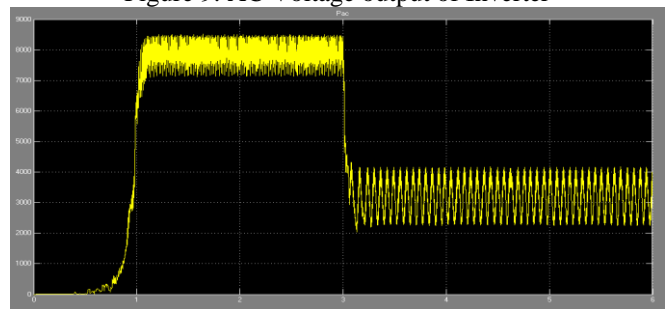

Figure 10. Wind Power

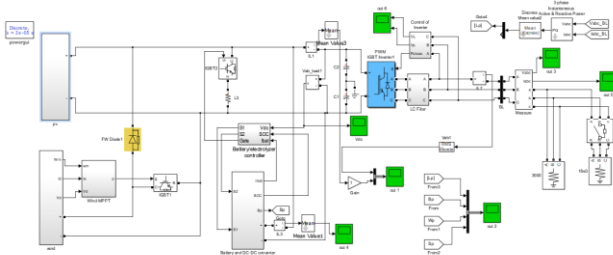

Figure 4. Top level Model

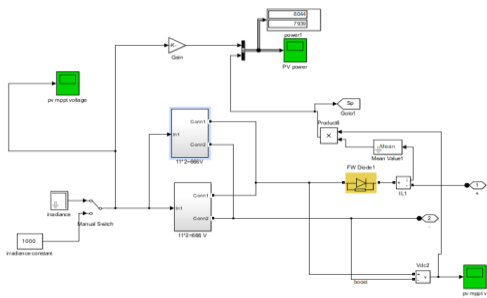

Figure 5. Detailed internal circuit diagram of PV array in Simulink

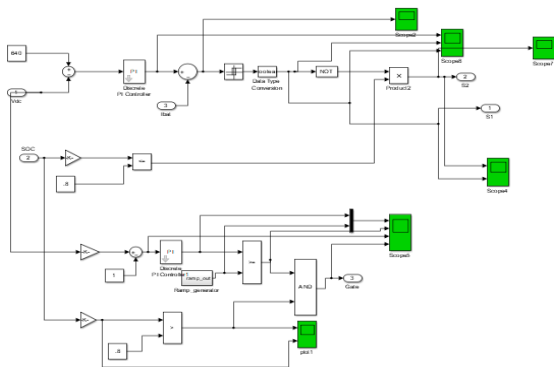

Figure 6. Battery Electrolyze Controller

The alternator with battery and inverter is the most economical solution for the three boxes for download. PV, wind turbine, diesel generator with battery and inverter system is also a very good replacement solution has low electricity cost and net current cost. Although the cost of electricity from the proposed system is higher than the electricity of the grid, but because of the need to protect the environment and the current standard of living of rural communities, this hybrid system will play a good role country, such as India. The integrated model provides great efficiency for people to make this energy extremely intelligent.

VII. CONCLUSIONS

- PV cell, module and array are simulated and effect of environmental conditions on their characteristics is studied.
- Wind energy system has been studied and simulated
- Maximum power point of operation is tracked for both the systems using P&O algorithm
- Both the systems are integrated and the hybrid system is used for battery charging and discharging
- Power & efficiency has been calculated and compare with existing system.

VIII. FUTURE SCOPE

- MPPT can be tracked using different algorithms
- Fuzzy Logic or Neural Network can be used for controlling purposes

REFERENCES

- [1] Guillermo Velasco-Quesada, Francisco Guinjoan "Electrical PV Array Reconfiguration Strategy for Energy Extraction Improvement in Grid-Connected PV Systems" IEEE Transactions On Industrial Electronics, Vol. 56, No. 11, November 2009 4319 0278-0046/\$26.00 © 2009 IEEE.
- [2] Jonathan Storey, Peter Wilson "Improved Optimization strategy for Irradiance Equalization in Dynamic Photovoltaic Arrays" Manuscript received May 15th, 2012.
- [3] Vijayalekshmy S, Bindu G R, and S Rama "Estimation of Power Losses in Photovoltaic Array Configurations under Passing Cloud Conditions" Proceedings of the World Congress on Engineering 2014 Vol I, WCE 2014, July 2 - 4, 2014, London, U.K. ISBN: 978-988-19252-7-5 ISSN: 2078-0958 (Print); ISSN: 2078-0966 (Online) WCE 2014.
- [4] Saravanan Kaliyaperumal, Sharmeela Chenniyappan "Low cost Dynamic Switching Technique for Improving the Power in Partially Shaded Photo Voltaic Array" International Journal of Control and Automation Vol.9, No.2 (2016), pp.61-70 <http://dx.doi.org/10.14257/ijca.2016.9.2.07> ISSN: 2005-4297 IJCA Copyright © 2016 SERSC.
- [5] Paula dos Santos Vicente, Tales Cleber Pimenta, and Enio Roberto Ribeiro "Photovoltaic Array Reconfiguration Strategy for Maximization of Energy Production" Hindawi Publishing Corporation International Journal of Photoenergy Volume 2015, Article ID 592383, 11 pages <http://dx.doi.org/10.1155/2015/592383>
- [6] R.L. Josephine, S. Suja, G. Karunambika "Combination of fixed configuration and reconfiguration method for maximum power extraction from PV arrays" dvances in Natural and Applied Sciences, 8(20) Special 2014, Pages: 67-72. R.L.Josephine., Department of Electrical and Electronics Engineering, Coimbatore Institute of Technology, Coimbatore, India.
- [7] V. Di Dio, D. La Cascia, C. Rando, G. Ricco Galluzzo "A new control system prototype for the energy production maximization of a unequally irradiated PV system" Copyright © 2011 MC2D & MITI University of Palermo - DIEET (Department of Electrical Electronic and Telecommunications Engineering) Viale delle Scienze, Edificio 9, 90128 Palermo.
- [8] F.Z Zerhouni, M.H Zerhouni, M. Zegrar, M.T Benmessaoul, A. Boudghene Stambouli "Increasing The Efficiency Of The Photovoltaic (PV) Array Utilization With Experimental Results" International Conference on Renewable Energies and Power Quality (ICREPQ'14) Cordoba (Spain), 8th to 10th April, 2014 ISSN 2172-038 X, No.12, April 2014.
- [9] D. Picault a,*, B. Raison a, S. Bacha a, J. de la Casa b, J. Aguilera b "Forecasting photovoltaic array power production subject to mismatch losses" Received 16 February 2010; received in revised form 9 April 2010; accepted 10 April 2010 Available online 12 May 2010.
- [10] F. D. Kanellos, A. I. Tsouchnikas, N. D. Hatzigiorgiou, Senior Member, IEEE "Micro Grid Simulation during Grid-Connected and Islanded Modes of Operation" Presented at the International Conference on Power Systems Transients (IPST'05) in Montreal, Canada on June 19-23, 2005 Synopsis No. IPST05 – 113.