

## SOLAR CELL BASED ON NATURAL DYE

Rahul Sharma<sup>1</sup>, Chandra Bhan<sup>2</sup>, Mohd.Sayed Abdaheer<sup>3</sup>  
<sup>1,2</sup>Assistant Professor (M.Tech), <sup>3</sup>Dean Academics,  
SIET, Sikar (Raj.)

**Abstract:** Natural Dye Sensitized Solar Cells NDSSC are a promising class of photovoltaic cells with the capability of generating green energy at low production cost since no vacuum systems or expensive equipment are required in their fabrication. Natural dyes are also abundant, safe and easily extracted. In NDSSC, once dye molecules exposed to light they become oxidized and transfer electrons to a nano structured layer of wide bandgap semiconductors such as TiO<sub>2</sub>. The generated electrons are drawn outside from the cell through ohmic contact to a load. In these papers we review the structure and operation principles of the dye sensitized solar cell DSSC

This work presents a Chukunder natural days in DSSCs. The parameters of interest were efficiency and stability. DSSCs were fabricated and V-I characteristics were studied on the first, day second and the tenth day. It gives higher efficiency.

**Keywords:** Solar Cell, DSSC, Black Grapes, TiO<sub>2</sub>, Acidic acid, Silicon Plate

### I. INTRODUCTION

A dye-sensitized solar cell (DSSC, DSC or DYSC) is a low-cost solar cell that belongs to the group of thin film solar cells. It is based on a semiconductor formed between a photo-sensitized anode and an electrolyte, a photo electrochemical system. The DSSC has a number of attractive features. It is simple to make using conventional roll-printing techniques, semi-flexible and semi-transparent which offers a variety of uses not applicable to glass-based systems and most of the materials used are at low-cost.

The titanium dioxide is immersed under an electrolyte solution, above which there is a platinum-based catalyst. Sunlight passes through the transparent electrode into the dye layer where it can excite electrons to flow into the titanium dioxide. The electrons flow toward the transparent electrode where they are collected for powering a load. After flowing through the external circuit, they are re-introduced into the cell on a metal electrode on the back, flowing into the electrolyte. The electrolyte then transports the electrons back to the dye molecules.

The use of natural pigments as sensitizing dye for the conversion of solar energy in electricity is interesting because on one hand it enhances the economical aspect and on the other it has significant benefits from the environmental point of view. Natural pigments extracted from fruits and vegetables, such as chlorophyll and anthocyanins, have been extensively investigated as sensitizers for DSSCs. This work investigates the use of Black Grapes as natural pigment.

### II. BACKGROUND

The main aim of the green generators or converters of energy is to replace the conventional (fossil) energy sources, hence reducing further accumulation of the Green House Gases GHGs. Conventional silicon and III-V semiconductor solar cell based on crystalline bulk, quantum well and quantum dots structure or amorphous and thin film structures provides a feasible solution. However, Natural Dye Sensitized Solar Cells NDSSC are a promising class of photovoltaic cells with the capability of generating green energy at low production cost since no vacuum systems or expensive equipment are required in their fabrication. Natural dyes are also abundant, safe and easily extracted. In NDSSC, once dye molecules exposed to light they become oxidized and transfer electrons to a nano structured layer of wide bandgap semiconductors such as TiO<sub>2</sub>.

### III. SOLAR CELL TERMINOLOGY

In this system used some terminology for making Solar Cell.

- Dye
- Electrode
- Nano
- Nanocrystalline
- Nonrenewable Energy Sources
- Organic
- Photovoltaic Cell: A device that converts radiant energy (photons or light) into electricity. Photo stands for photon and voltaic stands for the voltage produced from the photons.
- Tin Dioxide (SnO<sub>2</sub>)
- Titanium Dioxide (TiO<sub>2</sub>): The oxide of the metal titanium used as the white pigment in paint. It is found in nature as the minerals rutile and anatase. Titanium metal is used in the production of steels and corrosion resistant metal alloys of high strength.

Terms used for making the Solar Cell

Short Circuit Current (I<sub>sc</sub>)

Open Circuit Voltage (V<sub>oc</sub>)

Maximum Power (P<sub>m</sub>):-

$$P_{max} = V_{max} \times I_{max}$$

Fill Factor (FF)

$$FF = \frac{V_{max} \times I_{max}}{V_{oc} \times I_{sc}}$$

Efficiency (  $\eta$ ):-Efficiency is defined as ratio of energy output from solar cell to input energy from sun.

$$\eta = \frac{\text{Max cell power}}{\text{Incident light intensity}} = \frac{V_{max} \times I_{max}}{P_{in}} = \frac{V_{oc} I_{sc} FF}{P_{in}} \times 100$$

The efficiency is most commonly used parameter to compare the performance of one solar cell to another. Efficiency depends on solar spectrum, intensity of halogen and the temperature of solar cell.

#### IV. THE NANOCRYSTALLINE DYESENSITIZED SOLAR CELL

Modern solar cells, on other hand, are not wet photo electrochemical cells such as those described above. They were first developed over forty years ago by Bell Labs and are essential for us today since they power satellites and provide reliable electricity in remote locations. In the most common solar cells (formed from thin silicon wafers), electrons and holes are created by the absorption of light within the silicon (the semiconductor). Mobile electrons and holes transport the electrical current through the semiconductor and are thus responsible for the semiconductor's conductivity (see Figure 4.2). New technologies, which use thin films of semiconductor materials such as amorphous silicon polycrystalline silicon are under development and are finding applications in world markets as remote residential and third world village power sources and in consumer applications such as watches and calculators. Although over 100 million watts of conventional solar cells are currently produced each year for these applications, no solar cell technology has produced an efficient, reliable and cost-effective solar module that can be widely used to replace fossil fuel energy sources

In contrast to conventional solar cells, the nanocrystalline dye sensitized solar cell is a photo electrochemical cell. It resembles natural photosynthesis in two respects: 1) It uses an organic dye like chlorophyll to absorb light and produce a flow of electrons, and 2) It uses multiple layer to enhance both the light absorption and electron collection efficiency. Like photosynthesis, it is a molecular machine that is one of the first devices to go beyond microelectronics technology.

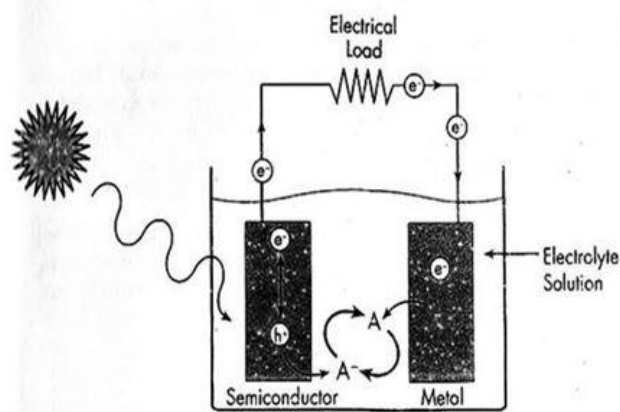

Fig. 1 A Photo electrochemical cell

To create the nanocrystalline solar cell, a suspension of nanometer size particles of titanium dioxide,  $TiO_2$ , is distributed uniformly on a glass ( $SiO_2$ ) slide which has previously been coated with a thin conductive and transparent layer of tin dioxide,  $SnO_2$ . The  $TiO_2$  film is dried and then heated on the glass to form a porous, high surface area  $TiO_2$  film. When magnified, it looks like a thin sponge or

membrane.

The  $TiO_2$  film on the glass slide is dipped into a solution of a dye such as an organ metallic complex or a green chlorophyll derivative. Many natural dyes can be utilized, but they must possess a chemical group that can attach (adsorb) to the  $TiO_2$  surface, and they must have energy levels at the proper positions necessary for electron injection and sensitization.

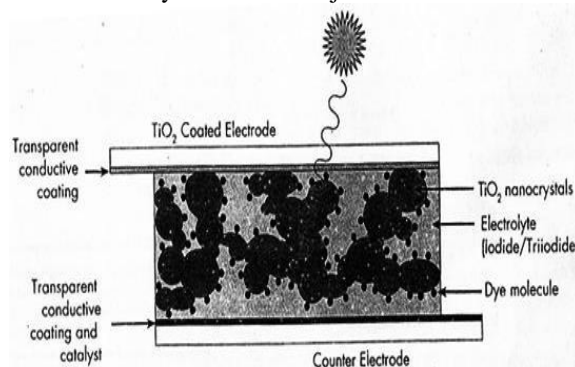

Fig 2 A single layer of dye (shown as black dots) adsorbing to the titanium dioxide ( $TiO_2$ ) nanocrystals in the nanocrystalline dye sensitized solar cell

The conversion efficiency of the solar cell is the maximum electrical power output divided by the incoming solar power on the same area. Of course, not all the energy from sunlight can be converted into electrical energy. Some of the sunlight is, instead, converted into heat. It is a consequence of the second law of thermodynamics that not more than 33% can convert into electricity for a solar cell with a single type of light absorber that is illuminated by natural daylight. The overall sunlight to electrical energy conversion efficiency or a nano crystalline solar cell using the best dyes currently available is 7-10% under direct sunlight. This is to be compared with approximately 0.5% for natural photosynthesis and 12-20% for commercial silicon solar cell modules. One process that limits the efficiency of the dye sensitized solar cell is the transfer of the injected electron to the oxidized mediator before the electron has been collected and passed through the load and counter electrode

#### IV. CREATING A SOLAR CELL

Background:-

Conventional solar cells convert light into electricity by exploiting the photovoltaic effect that exists in semiconductors, the semiconductor in a typical solar cell is a single crystal of silicon that performs two processes simultaneously:

Absorption of light and separation of the electric charges, negatively charged electrons and positively charged holes, are formed when light absorption excites electrons in the crystal to higher energy levels. The silicon used in conventional solar cells must be highly pure and defect-free. The nanocrystalline solar cell works on a different principle in which the processes of light absorption and charge separation are themselves separated. As shown in Figure 3, light absorption is performed by a single layer of dye (usually a metal organic compound or a metal complex) that is chemically attached to the rough surface of a layer of

interconnected titanium dioxide ( $\text{TiO}_2$ ) particles on conductive transparent glass. The minute particles of  $\text{TiO}_2$  are single crystals, ranging between 10 and 50 billionths- of a meter in size are called nanocrystalline. A simplified solar cell fabrication procedure, based on nanocrystalline dye sensitized solar cells, can demonstrate electron transfer easily and inexpensively.

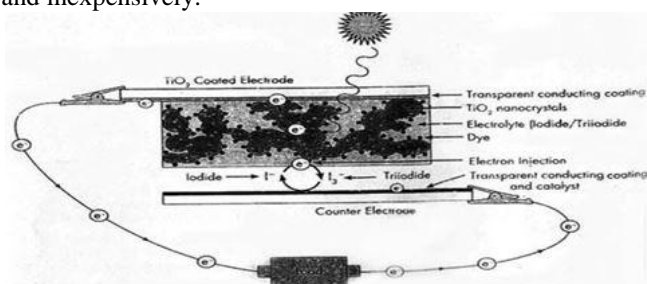

Fig. 3. Nano crystalline dye sensitized solar cell

Light excites electrons that can then be injected into the titanium dioxide nanocrystals. Electrons flow from the  $\text{TiO}_2$  coated electrode of the nano crystalline solar cell through the load and back to the counter electrode of the nano crystalline solar cell when the solar cell is excited by light (photons), the colored dye is able to transfer an electron to the semiconducting  $\text{TiO}_2$  layer. This process is called electron injection or sensitization. This electron transfer is actually similar to the process used in color photography. But the process that occurs after electron transfer is unique to be nano crystalline solar cell. The interconnected network of the porous  $\text{TiO}_2$  layer allows for the transport of the electron to the conductive layer on the glass where it is collected.

#### Objectives of the Experimental Procedure

This procedure will demonstrate the operating principles of the nanocrystalline solar cell and photosynthesis. The objectives of the experiment are: (a) to extract the natural dye (b) to deposit the  $\text{TiO}_2$  nanocrystalline ceramic film on conductive glass (c) to determine how the physical and the electronic coupling of an organic compound to an oxide semiconductor can occur via complexation and chelation and (d) to determine the current-voltage and power output to the chemical processes occurring in photosynthesis in green plants.

#### V. STEPS FOR THIS SYSTEM

##### Equipment and Materials List:-

- Conductive, tin dioxide coated, transparent glass slides per cell (2.54' cm X 2.54' cm) (included).
- 6 g colloidal titanium dioxide powder (per suspension batch) (included).
- Copper foil tape: 3M No. 1181 with pressure sensitive conductive adhesive (included).
- Iodide electrolyte solution in a dropper bottle (included): 0.5 M potassium iodide mixed with 0.05 M iodine in water-free ethylene glycol or a suitable organic solvent.
- Soft graphite pencil (HB woodless graphite pencil)

- (included). Graphite pencils can be purchased from any art supply store. Alternatively, an artist's charcoal pencil, a cleaned carbon rod taken from an alkaline battery or soot from a candle flame can be used
- Binder clips (included). Two clips are used per cell. The binder clips should be bent so that the pressure they exert may not too great. The jaws should be partially opened.
- Glassine envelopes for storing glass slides (included)
- Dropper bottle for  $\text{TiO}_2$  suspension (included)
- Surfactant (such as Triton X 100) or clear dishwashing detergent
- Light source: halogen lamp
- Heat Source
- Ceramic top hotplate (must be able to reach  $\sim 450^\circ\text{C}$ )
- Nitric or acetic acid solution (10 mL of pH 3-4 in deionized water < 0.001 M  $\text{HNO}_3$ ; < 0.057 M  $\text{CH}_3\text{COOH}$ ) or 0.2 mL acetyl acetone
- Polycarbonate (Lexan) plastic plate (2.5 cm X 2.5 cm)
- Ethanol and deionized water in wash bottles
- Black Grapes for organic dye
- Multimeter (2 digital multimeters are best)
- Alligator clips (large, they should exert a large pressure when closed)
- Hookup wire (black and red)
- Pipettes (or auto pipette)
- Mortar and pestle
- Clamps, ring stand and ring for positioning solar cell in light source
- Tweezers or forceps
- Tongs
- Petri dish or beaker
- Transparent tape
- Glass stirring rod
- Absorbent tissue paper
- Cotton swabs
- Filter paper and glassware for filtration
- Protective gloves and tight fitting

##### Deposition of Titanium Dioxide ( $\text{TiO}_2$ ) Film

Depositing the nanocrystalline  $\text{TiO}_2$  film requires (1) the preparation of a colloidal suspension containing commercial  $\text{TiO}_2$  powder, (2) the masking of a clean conductive glass slide (a conductive layer of fluorine doped tin dioxide,  $\text{SnO}_2$  is used as the substrate for the  $\text{TiO}_2$  film) and (3) the application and distribution of the  $\text{TiO}_2$  solution on the conductive glass slide, followed by the sintering of the resulting film layer.

The resulting 7-10 micrometer (micron) thick  $\text{TiO}_2$  film has a porous, sponge like structure that enhances both the light absorption and electron collection efficiency in a similar way as the thylakoid membrane founds in green plants. A magnified view of the resulting  $\text{TiO}_2$  nanocrystalline film is shown in figure 4



Fig 4:- porous nanocrystalline TiO<sub>2</sub> film at a magnification

Deposition of the TiO<sub>2</sub> film (Day one, Part two)

- Obtain and clean two glass conductive slides by rinsing them in ethanol and then drying with a soft tissue, use the same technique as with cleaning a pair of eyeglasses.
- Use a multimeter set to ohms to check which side of the glass is conductive; the reading should be between 10 and 30 ohms



Fig 5 Identify the conducting side of glasses

1. Orient one glass slide conductive side up. This slide will be coated with the TiO<sub>2</sub> suspension
2. Apply two 6-7 cm pieces of Scotch (3M) adhesive tape to the top faces of the glass slides to mask a strip not more than 1 mm wide on the two longer edges.
3. Apply another piece of adhesive tape along with the top of the glass to be coated with a mask 4-5 millimeter strip.

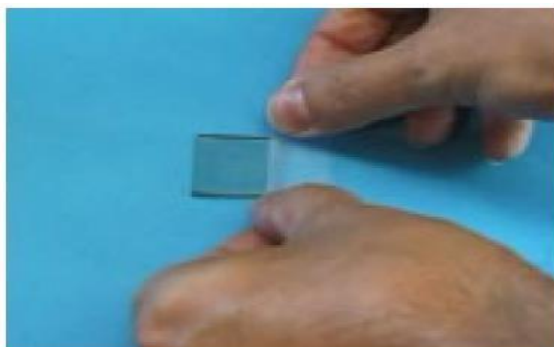

Fig. 6 A glass on three sides using one thickness of Scotch brand

This tape has a controlled thickness and will form a 40-50 micron deep mold or channel into which the TiO<sub>2</sub> suspension can flow.

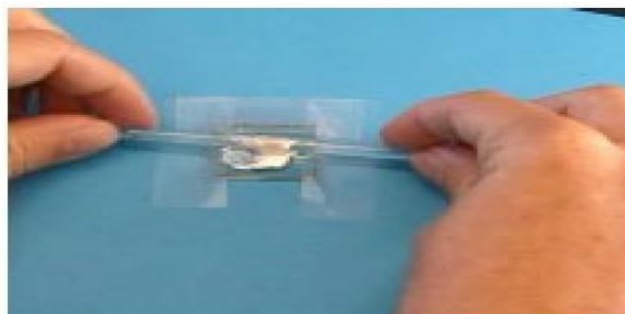

Fig. 7 The titanium dioxide paste and spread using a glass rod

To coat the glass, a thin line of the TiO<sub>2</sub> suspension is uniformly applied to the edge of the slide near the tape using the dropper bottle or a pipet. The amount of solution utilized is approximately 5 microliters per square centimeter ( $\mu\text{L}/\text{cm}^2$ ).

Within five seconds after application of the TiO<sub>2</sub> suspension, slide a clean glass stirring rod (held horizontally) over the slide to spread and distribute the material (see Figure 8)

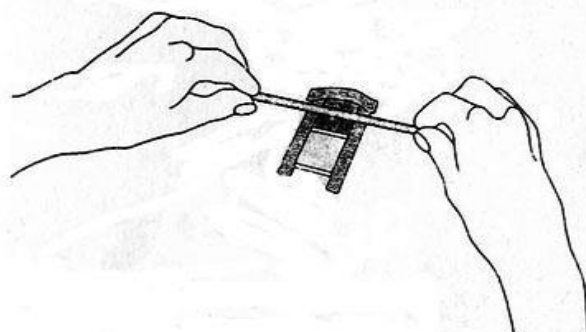

Fig. 8 A rapid sweeping motion with the glass rod is used to coat the titanium suspension (or paste) on the masked conductive glass slide

After deposition of the suspension, remove the tape carefully. Place the slide in a petri dish and cover it. Allow the TiO<sub>2</sub> film to dry for one minute. Wash clean the glass rod and dry the slide that was conductive side down.

Anneal the TiO<sub>2</sub> film on the conductive glass Heat the glass slide by using a ceramic top hotplate in a hood.



Fig 9 Heat the glass on a hotplate in a hood

Note: the hotplate must be able to reach a temperature of  $\sim 450^{\circ}\text{C}$ . place the glass slide (titanium dioxide film up) on top of the hotplate set on high. Heat for 10-20 minutes. During heating, the film may turn light brown and then back to white. After the annealing is completed, allow the TiO<sub>2</sub> coated conductive glass to cool the room temperature slowly. This will take approximately fifteen minutes.

Staining the TiO<sub>2</sub> with Anthocyanins Dye (Day Two, Part One)

Crush some fresh Pomegranate Seeds, in 2 mL ionized water and filter. The filtered solution is an anthocyanin dye solution.



Fig. 10 Immerse the coating in a source of anthocyanins such as black grapes

Place the anthocyanin solution in a beaker or petri dish and place the TiO<sub>2</sub> coated film in the solution face down. Soak the TiO<sub>2</sub> coated glass slide for 10 minutes in the filtered berry solution

Wash the film (which is stained a dark purple) in water and then in ethanol or isopropanol.

Gently blot dries the TiO<sub>2</sub> film with a tissue.

Carbon Coating the Counter Electrode

While the TiO<sub>2</sub> electrode is being stained in the berry juice or chlorophyll solution, the counter electrode can be made from another (2.5 cm × 2.5 cm) piece of conductive SnO<sub>2</sub> coated glass

Hold the conductive glass slide by the edges or with tweezers. Using a graphite (carbon) rod or soft pencil lead, apply a light carbon film to the entire conductive "side of the slide".

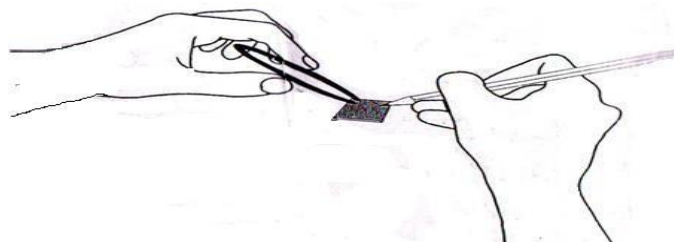

Fig. 11. Coaling of the counter electrode with the carbon catalyst layer

The catalysr coating on the counter electrode should not be touched. It should not be rubbed or slid against the TiO<sub>2</sub> electrode or any other surface. The counter electrode should be picked up at the edges and carefully placed where it is desired.



Fig. 12. Through a candle flame conducting side down

VI. RESULT

The completed solar cell or light detector can be taken outside and measured under illumination by sunlight. In order to protect the cell from damage by excessive UV light, a polycarbonate plastic cover should be placed over the cell. Light enters the glass "sandwich" through the TiO<sub>2</sub> coated glass slide. Measurements can be taken with a multimeter to determine if the procedure was successful. Maximum current and voltage output can easily be determined by attaching a multimeter directly to the two sides of the cell using wires with alligator clips attached to their ends.

Output characteristics of solar cell when Pomegranate is used as a natural dye

Day one

1.	Name of organic dye	Black Grapes
2.	Quantity of Dye	20 ml
3.	Light Intensity	600*10 lux
4.	Active Area of Solar cell	4cm <sup>2</sup>

TABLE 1:- INPUT PARAMETERS OF SOLAR CELL

S.No	Current(mA)	Voltage(V)
1	0	0.325
2	0.1	0.320
3	0.2	0.316
4	0.3	0.312
5	0.4	3.08
6	0.5	0.305
7	0.6	0.302
8	0.7	0.298
9	0.8	0.292
10	0.9	0.289
11	1.0	0.286
12	1.5	0.270
13	2.0	0.248
14	2.5	0.222
15	3.0	0.191
16	3.5	0.161
17	4.0	0.131
18	4.5	0.090
19	4.7	0.040
20	4.9	0

TABLE 2 OBSERVATION TABLE

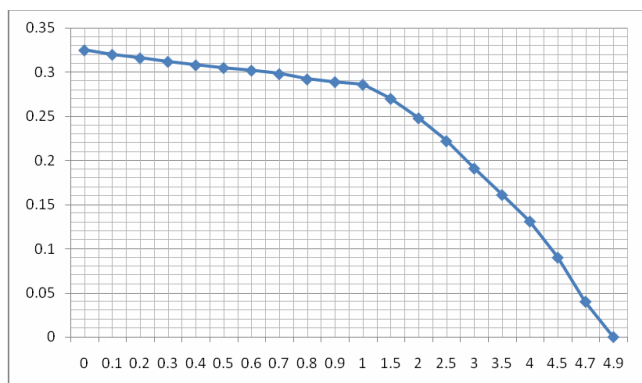

Fig. 13 Graph showing between current and voltage  
The output characteristics of solar cell on day one are shown in fig. 13. The graph shown & between current & voltage. The current is on x-axis and voltage is y-axis calculated the value of  $I_{max}$  and  $V_{max}$  using the graphs. The results are shown in table 3.

S.No	Parameters	Value
1	$I_{sc}$	2.0 mA
2	$V_{oc}$	0.25 V
3	$I_{max}$	0.25 mA
4	$V_{max}$	0.6V
5	$P_{max}$	0.140 mW
6	F.F	28.0%
7	$\eta$	3.00%

The efficiency on day ten is 3.00%.

## VII. CONCLUSION

Dye sensitized solar cells were fabricated using Black Grapes as a natural dyes. Output characteristics were measured on day one, day two and day ten for each.

When *Black Grapes* is used as natural dye on day one  $V_{oc}=0.325V$ ,  $I_{sc}= 4.9mA$ ,  $FF=17.90\%$  and  $\eta = 8.13\%$ .

On day two  $V_{oc}=0.30 V$ ,  $I_{sc}= 3.4mA$ ,  $FF= 15.2\%$  and  $\eta = 4.5\%$ . On day ten  $V_{oc}= 0.25 V$ ,  $I_{sc}=2.0 mA$ ,  $FF= 28\%$  and  $\eta = 3\%$ .

It is concluded that the Black Grapes have a highest efficiency on one day whereas on tenth day highest efficiency is of pomegranate. This conversion efficiency and stability can be checked to fabricated low cost solar cell.

## ACKNOWLEDGMENT

It is my pleasure and privilege to acknowledge and express my deep sense of gratitude to my teacher and guide, Dr. Saroj Sharma,(Associate Professor), Department of Physis MITS Laxmanghad, who inspired and initiated me to prepare this research despite his busy academic schedule.

I express my sincere thanks to Dr. Y.B Mathur for his encouragement.

Finally, words are insufficient to express my profound sense of gratitude to my friends Rahul Singh, whose encouragement and blessing gave me a great strength.

## REFERENCES

- [1] Jasim. Khalil Ebrahim, "Natural Dye-Sensitized Solar Cell Based on Nanocrystalline  $TiO_2$ ", *Sel Suria Terpeka Pewarna Semula Jadi Berasaskan Nanohablur  $TiO_2$* , Sains Malaysia 41(8), pp. 1011– 1016, 2012.
- [2] Mohammed Isah Kimpa1\*, Musa Momoh2, Kasim Uthman Isah1, Hassan Nawawi Yahya3, Muhammed Muhammed Ndamitso4, "Photoelectric Characterization of Dye Sensitized Solar Cells Using Natural Dye from Pawpaw Leaf and Flame Tree Flower as Sensitizers", *Materials Sciences and Applications*, vol-3, pp. 281- 286, 2012.
- [3] Mubarak A. Khan1\*,Shauk M M Khan1, Mahir Asif Mohammed2, Sabia Sultana1, Jahid M M Islam1and Jasim Uddin1, "Sensitization of Nanocrystalline Titanium dioxide Solar Cells using

S.No	Parameters	Value
1	$I_{sc}$	4.9 mA
2	$V_{oc}$	0.325 V
3	$I_{max}$	1.0mA
4	$V_{max}$	0.286V
5	$P_{max}$	0.286 mW
6	F.F	17.9%
7	$\eta$	8.13 %

Table 3 Output Characteristic Of Solar Cell

As shown in table 2, the efficiency on day one is 8.13%.  
Day 2

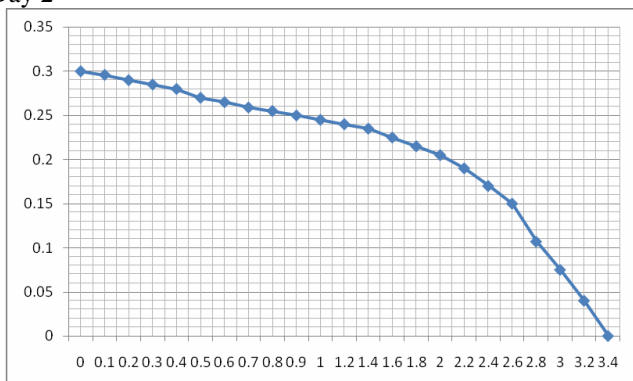

Fig. 14 Graph showing between current and voltage day two

S.No	Parameters	Value
1	$I_{sc}$	3.4 mA
2	$V_{oc}$	0.3 V
3	$I_{max}$	0.6 mA
4	$V_{max}$	0.26V
5	$P_{max}$	0.156 mW
6	F.F	15.2%
7	$\eta$	4.45%

The efficiency on day two is 4.45%.  
Day 10

- Natural Dyes: Influence of Acids Medium on Coating Formulation”, *American Academic & Scholarly Research Journal* Vol.-4, Sept 2012.
- [4] M. hossein. Bazargan, “Performance of nano structured dye- sensitized solar cell utilizing natural sensitizer operated with platinum and carbon coated counter electrodes”, *Digest journal of nanomaterials and biostructures*, vol.-4, pp. 723-727, December 2009.
- [5] Sahrul Saehana, Rita Prasetyowati, Marina I. Hidayat, Pepen Arifin, Khairurrijal, and Mikrajuddin Abdullah, “Efficiency improvement in TiO<sub>2</sub>-particle based solar cells after deposition of metal in spaces between particles”, *International Journal of Basic & Applied Sciences IJBAS-IJENS* Vol-11 No: 06, 2012.
- [6] Comparison of Dye-Sensitized Rutile- and Anatase-Based TiO<sub>2</sub> Solar Cells N.-G. Park, J. van de Lagemaat, and A. J. Frank National Renewable Energy Laboratory, Golden, Colorado 80401.
- [7] Ryohei Mori • Tsutomu Ueta • Kazuo Sakai • Yasuhiro Niida • Yasuko Koshihara • Li Lei • Katsuhiko Nakamae • Yasukiyo Ueda Organic solvent based TiO<sub>2</sub> dispersion paste for dye-sensitized solar cells prepared by industrial production level procedure *J Mater Sci*, DOI 10.1007/s10853-010-4925-2 Springer Science + Business Media, LLC 2010.