

# INTELLIGENT REMOTE MONITORING OF FUEL LEVEL DATA MANAGEMENT USING INTERNET OF THINGS

A.Shabina<sup>1</sup>, Ms.K.Kiruthika M.E<sup>2</sup>

<sup>1</sup>PG Scholar/ Dept. of ECE, <sup>2</sup> Assistant Professor/Dept. of ECE,

<sup>1</sup>Karpaga Vinayaga College of Engineering and Technology, Kancheepuram District ,Tamil Nadu, India

**Abstract:** Monitoring Systems are necessary to track and understand the changes that take place in environments. Remote monitoring and data collection systems are useful and effective tools to collect information from fuel storage tanks. The fuel management system is a monitoring device built on the Raspberry-Pi computer; it takes information about tank's fuel level in real time through its sensor and live streaming of the site, then uploads it directly to the internet, where it can be read anytime and anywhere through web application. This paper presents the implementation of monitoring system based on internet of things technology to protect the tower sites from theft and provide security to remote locations.

**Keywords:** Raspberry-Pi, fuel level, GPS

## I. INTRODUCTION

As fuel prices climb, some issues and challenges are facing telecom industry regarding the power supply of towers. "In some African countries up to 80% of the tower sites have no access to the power grid; those sites are usually powered by diesel or gasoline generators". "Between 20% and 35% of the fuel intended for powering the tower site in Africa is stolen", which results in financial losses to telecom companies. To avoid this, we are implementing such a system; we have used Internet of things which has become a basic and necessary technology for monitoring of remote location via web or android application. The installation of around 75,000 new towers around the world every year that are off-grid shows clearly the rising importance of fuel management system. Internet of Things (IoT) is a concept and a paradigm that considers pervasive presence in the environment of a variety of things that through wireless and wired connections and unique addressing schemes are able to interact with each other and cooperate with other things to create new applications/services and reach common goal. A world where the real, digital and the virtual are converging to create smart environments that make energy, transport, cities and many other areas more intelligent. The goal of the Internet of Things is to enable things to be connected anytime, anyplace, with anything and anyone ideally using any path/network and any service.

IoT architecture consists of different suite of technologies supporting it. It serves to illustrate how various technologies relate to each other and to communicate the scalability, modularity and configuration of IoT deployments in different scenarios. The functionality of each layer is described below: Sensor Layer The lowest layer is made up of smart objects integrated with sensors. The main function of this layer is to obtain the various types of static / dynamic information of the

real world through various types of sensors and to share with Internet access. Gateways and Networks Large volume of data will be produced by these sensors and this requires a robust and high performance wired or wireless network infrastructure as a transport medium.

The network helps to distinguish each object that is interconnected in the physical world. Current networks, often tied with very different protocols, have been used to support machine-to-machine (M2M) networks and their applications. Management Service Layer The management service renders the processing of information possible through analytics, security controls, process modelling and management of devices. One of the important features of the management service layer is the business and process rule engines. Data management is the ability to manage data information flow. With data management in the management service layer, information can be accessed, integrated and controlled. Application Layer This layer at the top of the stack is responsible for delivery of various applications to different users in IoT. It consists of protocols that focus on process-to-process communication across an IP network and provides a firm communication interface and end-user services.

## II. RELATED WORKS

Vehicle automation is a technology by which we can control different things or can keep a track on a vehicle for the security, comfort and efficiency. In order to support the safety and security, multiple applications have been developed. Recently, a concept of automation is gaining popularity because of technology and low cost and simplicity of Smartphone and connectivity between them. In this Existing system Vehicle automation using raspberry pi approach to monitoring the different parameters such as temperature, humidity, fuel indication speed of a Vehicle and we can also track the location of the Vehicle. By using this technology we can monitor our vehicle from anywhere in the world. In past few years, there were major contributions of electronics engineers to automate the Vehicle. They invented ECU (engine control unit) to sense many parameters in Vehicle and also control them. By using several ECUs in Vehicle improves the efficiency of the engine, reduction in requirement of fuel & overall it reduces expenses.

## III. PROPOSED METHODOLOGY

Our proposed implementation of fuel monitoring and assistance system based on GPS tracking integrated with Google Maps. Fuel monitoring have been the major problem that most of companies looking to solve. With the help of fuel level sensor and Raspberry-Pi system can sense the fuel

level of the tank in real time .This project developed a fuel bunk tracking and monitoring the fuel system to provide a facility for the management requirements by the administrator.

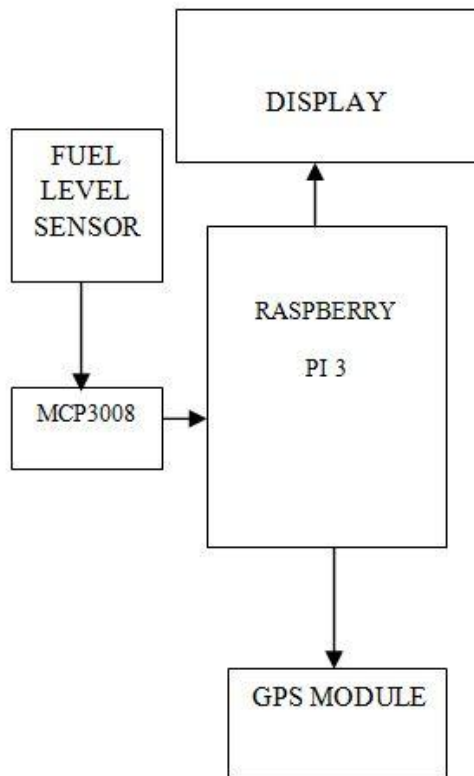

Figure: Block Diagram of Proposed System

**Sensor System:** Sensors system is composed of fuel level sensors. i.e. reed switch ,**Power System:** The central control system is powered by DC power supply with proper specifications. The communication system i.e. GPS and sensor system are also powered by this power supply. **Central Control System:** This is the heart of the monitoring system. It consists of microcontroller with appropriate interfacing with other devices. It performs all the control actions required for proper operation of all the system.

## HARDWARE REQUIREMENT

### RASPBERRY PI

The Raspberry Pi is a series of small single-board computers developed in the United Kingdom by the Raspberry Pi Foundation to promote the teaching of basic computer science in schools and in developing countries. The original model became far more popular than anticipated, selling outside of its target market for uses such as robotics. Peripherals (including keyboards, mice and cases) are not included with the Raspberry Pi. Some accessories however have been included in several official and unofficial bundles.

According to the Raspberry Pi Foundation, over 5 million Raspberry Pi is have been sold before February 2015, making it the best-selling British computer. By November 2016 they had sold 11 million Several generations of Raspberry Pi have been released. The first generation

(Raspberry Pi 1 Model B) was released in February 2012. It was followed by a simpler and inexpensive model Model A. In 2014, the foundation released a board with an improved design in Raspberry Pi 1 Model B+. These boards are approximately credit-card sized and represent the standard mainline form-factor. Improved A+ and B+ models were released a year later. A "compute module" was released in April 2014 for embedded applications and a Raspberry Pi Zero with smaller size and reduced input/output (I/O) and general-purpose

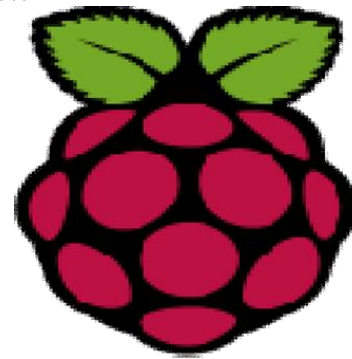

An input/output (GPIO) capability was released in November 2015 for US\$5. The Raspberry Pi 2 which added more RAM was released in February 2015. Raspberry Pi 3 Model B released in February 2016, is bundled with on-board Wi-Fi, Bluetooth and USB boot capabilities. As of January 2017, Raspberry Pi 3

Model B is the newest mainline Raspberry Pi. Raspberry Pi boards are priced between US\$5–35. As of 28 February 2017, the Raspberry Pi Zero W was launched, which is identical to the Raspberry Pi Zero, but has the Wi- Fi and Bluetooth functionality of the Raspberry Pi 3 for US\$10

All models feature a Broadcom system on a chip (SoC), which includes an ARM compatible central processing unit (CPU) and an on-chip graphics processing unit (GPU, a Video Core IV). CPU speed ranges from 700 MHz to 1.2 GHz for the Pi 3 and on board memory range from 256 MB to 1 GB RAM. Secure Digital (SD) cards are used to store the operating system and program memory in either the SDHC or MicroSDHC sizes. Most boards have between one and four USB slots, HDMI and composite video output, and a 3.5 mm phone jack for audio. Lower level output is provided by a number of GPIO pins which support common protocols like I<sup>2</sup>C. The B-models have an 8P8C Ethernet port and the Pi 3 and Pi Zero W have on board Wi-Fi 802.11n and Bluetooth.

The Foundation provides Raspbian, a Debian-based Linux distribution for download, as well as third party Ubuntu, Windows 10 IOT Core, RISC OS, and specialized media center distributions. It promotes Python and Scratch as the main programming language, with support for many other languages. The default firmware is closed source, while an unofficial open source is available

### RASPBERRY PI 3

The Raspberry Pi 3 Model B is the third generation Raspberry Pi. This powerful credit-card sized single board computer can be used for many applications and supersedes

the original Raspberry Pi Model B+ and Raspberry Pi 2 Model B.

Whilst maintaining the popular board format the Raspberry Pi 3 Model B brings you a more powerful processor, 10x faster than the first generation Raspberry Pi. Additionally it adds wireless LAN & Bluetooth connectivity making it the ideal solution for powerful connected designs.

The Raspberry Pi 3 is the third generation Raspberry Pi. It replaced the Raspberry Pi 2 Model B in February 2016. The Raspberry Pi 3 has an identical form factor to the previous Pi 2 (and Pi 1 Model B+) and has complete compatibility with Raspberry Pi 1 and 2. The best part about all this is that the Pi 3 keeps the same shape, connectors, and mounting holes as the Pi 2. Dual Core Video Core IV® Multimedia Co-Processor. Provides Open GL ES 2.0, hardware-accelerated OpenVG, and 1080p30 H.264 high-profile decode



FIGURE: Raspberry Pi 3

**MCP3008**

MCP3008 is a 10bit 8-channel ADC (Analog to digital converter) which uses the SPI bus protocol and allows you to get the analog inputs with Raspberry Pi. It is cheap and don't require any additional components with it. It gives you 8 analog inputs and it uses just four pins of Raspberry Pi excluding the power and ground pins. MCP3008 is a 10 bit ADC so it will give us output up to  $(2^{10} - 1) = 1023$ . So the output will be a range from 0-1023 where 0 means 0V and 1023 mean 3.3V.

**MCP3008 Pin out**

The pin1 of the MCP3008 starts from below the half circle you can see in the pin out diagram. MCP3008 ADC has a total of 16 pins out of which 8 pins are for taking the analog input. The analog input pins are from CH0-CH7 (Pins 1-8). On the other side, we have different pins which are as follows

DGND is digital ground pin for the chip.

CS is the chip select pin.

DIN is the data input pin from the Raspberry Pi.

DOUT is the data output pin.

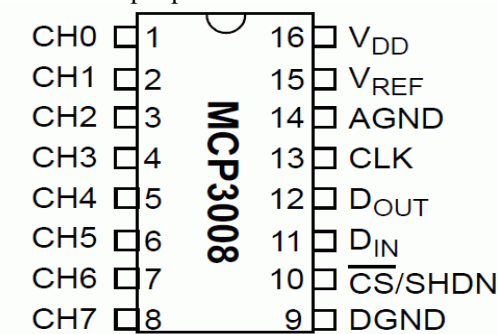

FIGURE: PIN DIAGRAM OF MCP3008

The Microchip Technology Inc. MCP3004/3008 devices are successive approximation 10-bit Analog to-Digital (A/D) converters with on-board sample and hold circuitry. The MCP3004 is programmable to provide two pseudo-differential input pairs or four single ended inputs. The MCP3008 is programmable to provide four pseudo-differential input pairs or eight single ended inputs. Differential Nonlinearity (DNL) and Integral Nonlinearity (INL) are specified at  $\pm 1$  LSB. Communication with the devices is accomplished using a simple serial interface compatible with the SPI protocol. The devices are capable of conversion rates of up to 200 ksp/s. The MCP3004/3008 devices operate over a broad voltage range (2.7V - 5.5V). Low current design permits operation with typical standby currents of only 5 nA and typical active currents of 320  $\mu$ A. The MCP3004 is offered in 14-pin PDIP, 150 mil SOIC and TSSOP packages, while the MCP3008 is offered in 16-pin PDIP and SOIC packages.

**Fuel Level sensor**

Level sensors detect the level of liquids and other fluids and powders that exhibit an upper free surface. Substances that flow become essentially horizontal in their containers (or other physical boundaries) because of gravity whereas most bulk solids pile at an angle of repose to a peak. There are many physical and application variables that affect the selection of the optimal level monitoring method for industrial and commercial processes. The selection criteria include the physical: phase (liquid, solid or slurry), temperature, pressure or vacuum, chemistry, dielectric constant of medium, density (specific gravity) of medium, agitation (action), acoustical or electrical noise, vibration, mechanical shock, tank or bin size and shape Level sensors detect the level of substances that flow, including liquids, Slurries, granular materials, and powders. The substance to be measured can be inside a container or can be in its natural form. The level measurement can be either continuous or point values. Continuous level sensors measure level within a specified range and determine the exact amount of substance in a certain place. While point-level sensors only indicate whether the substance is above or below the sensing point generally the latter detect levels that are excessively high or low. Selection of an appropriate type of sensor suiting to the application requirement is very important.



FIGURE Fuel Level Sensor

**FEATURES**

- Input voltage: 5v
- Output: Analog.

- Output voltage: 0-3v
- Level detecting range: 0 to .2m.
- Level is determined with the resistance.

### Global Positioning System (GPS)

The Global Positioning System (GPS) is a global navigation satellite system that provides location and time information in all weather conditions. The GPS operates independently of any telephonic or internet reception, though these technologies can enhance the usefulness of the GPS positioning information. GPS satellites transmit signal information to earth. This signal information is received by the GPS receiver in order to measure the user's correct position.

The Global Positioning System (GPS), originally Navstar GPS, is a satellite-based radio navigation system owned by the United States government and operated by the United States Air Force. It is a global navigation satellite system that provides geo location and time information to a GPS receiver anywhere on or near the Earth where there is an unobstructed line of sight to four or more GPS satellites. Obstacles such as mountains and buildings block the relatively weak GPS signals.

The GPS does not require the user to transmit any data, and it operates independently of any telephonic or internet reception, though these technologies can enhance the usefulness of the GPS positioning information. The GPS provides critical positioning capabilities to military, civil, and commercial users around the world. The United States government created the system, maintains it, and makes it freely accessible to anyone with a GPS receiver.

The GPS project was launched by the U.S. Department of Defense in 1973 for use by the United States military and became fully operational in 1995. It was allowed for civilian use in the 1980s. Advances in technology and new demands on the existing system have now led to efforts to modernize the GPS and implement the next generation of GPS Block IIIA satellites and Next Generation Operational Control System (OCX). Announcements from Vice President Al Gore and the White House in 1998 initiated these changes. In 2000, the U.S. Congress authorized the modernization effort, GPS III. During the 1990s, GPS quality was degraded by the United States government in a program called "Selective Availability"; this was discontinued in May 2000 by a law signed by President Bill Clinton.

The GPS system is provided by the United States government, which can selectively deny access to the system, as happened to the Indian military in 1999 during the Kargil War, or degrade the service at any time. As a result, several countries have developed or are in the process of setting up other global or regional satellite navigation systems. The Russian Global Navigation Satellite System (GLONASS) was developed contemporaneously with GPS, but suffered from incomplete coverage of the globe until the mid-2000s. GLONASS can be added to GPS devices, making more satellites available and enabling positions to be fixed more quickly and accurately, to within two meters. China's BeiDou Navigation Satellite System is due to achieve global reach in 2020. There are also the European Union Galileo positioning

system, and India's NAVIC. Japan's Quasi-Zenith Satellite System (scheduled to commence in November 2018) will be a GPS satellite-based augmentation system to enhance GPS's accuracy.

When selective availability was lifted in 2000, GPS had about 5 meter accuracy. The latest stage of accuracy enhancement uses the L5 band and is now fully deployed. GPS receivers released in 2018 that use the L5 band can have much higher accuracy, pinpointing to within 30 centimeters, or just less than one foot.



FIGURE Global Positioning System

The GPS concept is based on time and the known position of specialized satellites. GPS satellites continuously transmit their current time and position. A GPS receiver monitors multiple satellites and solves equations to determine the precise position of the receiver and its deviation from true time. At a minimum, four satellites must be in view of the receiver for it to compute four unknown quantities. Each GPS satellite continually broadcasts a signal (carrier wave with modulation) that includes a pseudorandom code (sequence of ones and zeros) that is known to the receiver and a message that includes the time of transmission (TOT) of the code epoch and the satellite position at that time.

### FEATURES

- Supply voltage: 12v DC
- Interface: UART RS232
- Optional T-TL uart also available
- Precision: 5 meters
- Automatic antenna switching function

### APPLICATIONS

- GPS trackers
- Automated vehicle
- Robotics
- Fleet tracking

### IV. IMPLEMENTATION RESULTS

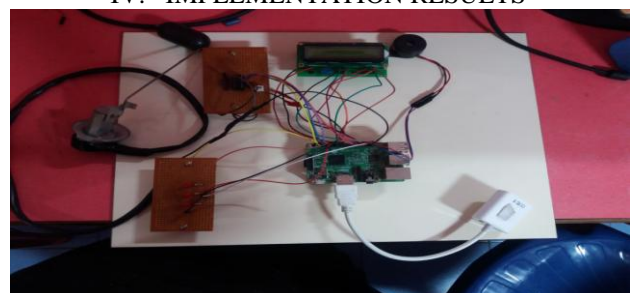

## V. CONCLUSION

Due to rising price of fuel, fuel theft has become very common incidence. Our project is very useful for a common man as it avoids him by getting cheated. Whenever there is large decrease in fuel level in tank the system is activated giving the owner the precise indication of fuel content. The system will help to owner of vehicle to get the information about fair level of fuel in tank and also location and route to the petrol station.

## REFERENCES

- [1] Abd Elmonem Yosif, Murtada Mohamed Abdelwahab, Mohamed Abd Elrahman Alagab, Fares Muhammad. Design of bus tracking and fuel monitoring system. IEEE conference, March 2017.
- [2] Mohammad Salah Uddin, Md. Mohiuddin Ahmad, Jannat Binta Alam, Maruf Islam. Smart anti-theft vehicle tracking system for Bangladesh based on Internet of Things. IEEE conference, Jan 2017.
- [3] Fuel monitoring and vehicle tracking Sachin S. Aher, Kokate R. D System for remote monitoring of a vehicle and method of determining vehicle mileage, jurisdiction crossing and fuel consumption.
- [4] "System for remote monitoring of a vehicle and method of determining vehicle mileage, jurisdiction crossing and fuel consumption."
- [5] P. F. Ovidiu Vermesan, Internet of Things: Converging Technologies for Smart Environments and Integrated Ecosystems. 2013.
- [6] M. Abu-Elkheir, M. Hayajneh, and N. A. Ali, "Data management for the Internet of Things: Design primitives and solution," *Sensors (Switzerland)*, vol. 13, no. 11, pp. 15582–15612, 2013.
- [7] D. Bandyopadhyay and J. Sen, "Internet of things: Applications and challenges in technology and standardization," *Wirel. Pers. Commun.*, vol. 58, no. 1, pp. 49–69, 2011.
- [8] Ravi Kishore Kodali, Vishal Jain, Suvadeep Bose and Lakshmi Boppana, "IoT Based Smart Security and Home Automation," in International Conference on Computing, Communication and Automation (ICCCA), 2016.
- [9] Kumar Mandula, Ramu Parupalli, CH.A.S.Murty, E.Magesh, Rutul Lunagariya, "Mobile based Home Automation using Internet of Things(IoT)," in International Conference on Control, Instrumentation, Communication and Computational Technologies (ICCICCT), 2015.
- [10] Vamsikrishna Patchava, Hari Babu Kandala,, P Ravi Babu, "A Smart Home Automation Technique with Raspberry Pi using IoT," in International Conference on Smart Sensors and Systems (IC-SSS), 2015.
- [11] Pavithra.D, Ranjith Balakrishnan, "IoT based Monitoring and Control System for Home Automation," in Proceedings of 2015 Global Conference on Communication Technologies(GCCT 2015).
- [12] Soumya S, Malini Chavali, Shuchi Gupta, Niharika Rao, "Internet of Things based Home Automation System," IEEE International Conference On Recent Trends In Electronics Information Communication Technology, May 20-21, 2016.
- [13] Simon Monk, Raspberry Pi Cookbook. O'Reilly Media, 2014.
- [14] Mr. Atonu Ghosh, "Intelligent Appliances Controller Using Raspberry Pi Through Android Application & Browser," in 2016 IEEE 7th Annual Information Technology, Electronics and Mobile Communication Conference (IEMCON).
- [15] Ryan Krauss, "Combining Raspberry Pi and Arduino to Form a Low-Cost, Real-Time Autonomous Vehicle Platform," in 2016 American Control Conference (ACC).
- [16] Mr. Sandip Balaso Khot, Dr. M. S. Gaikwad, "Development of Cloud-Based Light Intensity Monitoring System For Green House Using Raspberry Pi," 2016 International Conference on Computing Communication Control and automation (ICCUBEA).
- [17] Ahmed, A. A. (2017). Fuel Management System. 2017 International Conference on Communication, Control, Computing and Electronics Engineering (ICCCCEE), Khartoum, Sudan, 7.
- [18] Modeling and Nonlinear Control of Fuel Cell / Supercapacitor Hybrid Energy Storage System for Electric Vehicles. (2014). 26.
- [19] Vural, B. (2015). Fuel Consumption Comparison of Different Battery/Ultracapacitor Hybridization Topologies for Fuel-Cell Vehicles on a Test Bench. IEEE JOURNAL OF EMERGING AND SELECTED TOPICS IN POWER ELECTRONICS, VOL. 2, NO. 3, SEPTEMBER 2014, 12.