

## FABRICATION OF AIR BRAKE SYSTEM USING ENGINE EXHAUST GAS

Harsha BT<sup>1</sup>, G Rajesh<sup>2</sup>, Arunkumar K<sup>3</sup>, Akash SM<sup>4</sup>, Preethi Reddymasi<sup>5</sup>

<sup>1</sup>Assistant Professor, <sup>2,3,4,5</sup>UG Scholar

Mechanical Engineering, Ballari Institute of Technology and Management, Karnataka, India

**ABSTRACT:** *The aim is to design and to develop an air brake system based on exhaust gas is called "fabrication of air brake system using engine exhaust gas". The main aim of this project is to reduce the workloads of the engine drive to operate the air compressor, because here the compressor is not operated by the engine drive.*

*Here we are placing a turbine in the path of exhaust from the engine. The turbine is connected to a dynamo by means of coupling, which is used to generate power. Depending upon the airflow the turbine will start rotating, and then the dynamo will also starts to rotate. A dynamo is a device which is used to convert the kinetic energy into electrical energy. The generated power can be stored in the battery and then this electric power has loaded to the D.C compressor. The air compressor compresses the atmospheric air and it stored in the air tank and the air tank has pressure relief valve to control the pressure in the tank. The air tank supplies the compressed pneumatic power to the pneumatic actuator through solenoid valve to apply brake. The pneumatic actuator is a double acting cylinder which converts hydraulic energy into linear motion.*

**Keyword:** - *Dynamo, DC Compressor, and Pressure relief valve etc....*

### I. INTRODUCTION

We waste so much energy. As much as 60 percent of energy is wasted as heat. Our laptops, nuclear power plants, chemical factories and cars all contribute to this waste heat. Researchers at Purdue University are working with General Motors to create thermoelectric generators (TEGs) to turn waste heat directly into electrical energy for cars. The idea is to use the heat from the car engine's exhaust to generate electricity. The prototype which is a small metal chip will basically hook up to the exhaust system and tap into heat coming from the gases. The technology used today can't hold up against the high temperatures inside catalytic converters. But the material the researchers want to use is called skutterudite, which is a mix of minerals. Then other rare metals are added to it to make sure it's a poor conductor. That way, the current is generated when the material is hot on one side and cold on the other. Ideally, it would reduce the amount of fuel used by five percent. It does this as it generates electricity to help power the car's electrical system and charge its battery. The applications of the technology go beyond car exhaust. It could generate electricity in homes and power plants from waste streams. Waste byproducts could supply 19 percent of U.S. power, the heat sure gets lost easily. The promise is there, but the technical hurdles remain.

A Purdue University team, in collaboration with General Motors, is setting out to develop a new type of thermoelectric generator that can convert heat from a car's exhaust into electricity. The first prototype of the energy saving technology could reduce fuel consumption by 5 to 10 percent. The idea is to place a device built from thermoelectric materials (materials that can generate an electrical current from temperature differences) in the exhaust system behind the catalytic converter, where heat from gasses can reach temperatures nearing 1,000 degrees Celsius. That heat could then be converted into electricity by the thermoelectric materials. "The material is hot on the side facing the exhaust gases and cool on the other side, and this difference must be maintained to continually generate a current", said Xianfan Xu, a Purdue professor working on the project. One obstacle that has prevented technology like this from succeeding before is that current thermoelectric material cannot withstand the sweltering temperatures inside catalytic converters. That's what the Purdue team aims to remedy. For instance, the first prototype can harvest heat from gasses that are about 700 degrees Celsius. "The biggest challenge is system level design how to optimize everything to get as much heat as possible from the exhaust gas", Xu said. "The engine exhaust has to lose as much heat as possible to the material".

The electricity generated from the exhaust could then help power a car's electrical systems, reducing strain on the engine and ultimately improving fuel economy. Helping your auto to puff-puff along more efficiently is only the start of what this new technology could achieve, however. Thermoelectric technologies can also be used for other applications such as harnessing waste heat to generate electricity in homes and power plants. They might even lead to the development of a new type of solar cell or a solid-state refrigerator, said Xu.

### II. LITERATURE SURVEY

EGR is effective to reduce nitrogen oxides (NOx) from Diesel engines because it lowers the flame temperature and the oxygen concentration of the working fluid in the combustion chamber. However, as NOx reduces, particulate matter (PM) increases, resulting from the lowered oxygen concentration. When EGR further increases, the engine operation reaches zones with higher instabilities, increased carbonaceous emissions and even power losses. In this research, the paths and limits to reduce NOx emissions from Diesel engines are briefly reviewed, and the inevitable uses of EGR are highlighted. The impact of EGR on Diesel operations is analyzed and a variety of ways to implement

EGR are outlined. Thereafter, new concepts regarding EGR stream treatment and EGR hydrogen reforming are proposed. Partial combustion of biomass in the gasifier generates producer gas that can be used for heating purposes and as supplementary or sole fuel in internal combustion engines. In this study, the potential of coir-pith and wood chips as the feedstock for gasifier is analyzed. The performance of the gasifier-engine system is analyzed by running the engine for various producer gas-air flow ratios and at different load conditions. The system is experimentally optimized with respect to maximum diesel savings and lower emissions in the dual fuel mode operation while using coir-pith and wood chips separately. The performance and emission characteristics of the dual fuel engine are compared with that of diesel engine at different load conditions. Specific energy consumption in the dual fuel mode of operation is found to be in the higher side at all load conditions. The brake thermal efficiency of the engine while using wood chips in the dual mode operation is higher than that of coir-pith. The CO emission is higher in the case of dual fuel mode of operation as compared to that of diesel mode. In the dual fuel mode of operation, the higher diesel savings is achieved while using wood chips as compared to that of coir-pith. The comparison of the performance and emission characteristics of the dual fuel engine with diesel engine is also described

This article gives an overview of power generation with gas turbine and combined heat and power (CHP) systems. It also presents the European Union strategy for developing gas turbines and CHP systems. Ways to improve the performance of the several types of gas turbine cycle will be a major objective in the coming years. The targets are combined cycle efficiencies above 60% industrial gas turbine system efficiencies of at least 50% and small gas turbines efficiencies above 35% and designs for the use of fuels with less than 25% heating value of that of natural gas. The main CHP targets are the reduction of the overall costs and the development of above 40 kW biomass-fired systems.

### III. DESCRIPTION OF EQUIPMENTS

#### 3.1 Engine

An engine is a machine designed to convert chemical energy into useful mechanical motion. Heat engines, including internal combustion engines and external combustion engines (such as steam engines) burn a fuel to create heat, which then creates motion. The internal combustion engine is classified into two types and they are diesel engine and petrol engine. Originally, an engine was a mechanical device that converted force into motion. Military devices such as catapults, trebuchets and battering rams are referred to as siege engines. The term "gin" as in cotton gin is recognized as a short form of the Old French word engine, in turn from the ingenious, related to ingenious. Most devices in the industrial revolution were called engines, and this is where the steam engine gained its name. The term motor was originally used to distinguish the new internal combustion engine-powered vehicles from earlier vehicles powered by steam engines, such as the steam roller and motor roller, but may be used to refer to any engine.

#### 3.2 Carburetor

The carburetor works on Bernoulli's principle, the faster air moves, the lower its static pressure, and the higher its dynamic pressure. The throttle (accelerator) linkage does not directly control the flow of liquid fuel. Instead, it actuates carburetor mechanisms which meter the flow of air being pulled into the engine. The speed of this flow, and therefore its pressure, determines the amount of fuel drawn into the airstream. When carburetors are used in aircraft with piston engines, special designs and features are needed to prevent fuel starvation during inverted flight. Later engines used an early form of fuel injection known as a pressure carburetor. Most production carbureted (as opposed to fuel injected) engines have a single carburetor and a matching intake manifold that divides and transports the air fuel mixture to the intake valves, though some engines (like motorcycle engines) use multiple carburetors on split heads. Multiple carburetor engines were also common enhancements for modifying engines in the USA from the 1950s to mid-1960s, as well as during the following decade of high performance muscle cars fueling different chambers of the engine's intake manifold.

### IV. WORKING

A two stroke engine powered by petrol is used to produce exhaust gas. Here we are placing a turbine in the path of exhaust from the silencer. The turbine is connected to a dynamo, which is used to generate power. Depending upon the airflow the turbine will start rotating thus rotating the dynamo. A dynamo is a device which is used to convert the kinetic energy into electrical energy. The generated electric power is stored in a battery after rectification. Thus the stored electrical power is use to run the DC compressor the compressor compresses the atmospheric air and it is stored in an air tank. When the brake is applied the 5/2 solenoid valve is activated and it allows the air to actuates the pneumatic cylinder thus the brake is applied.

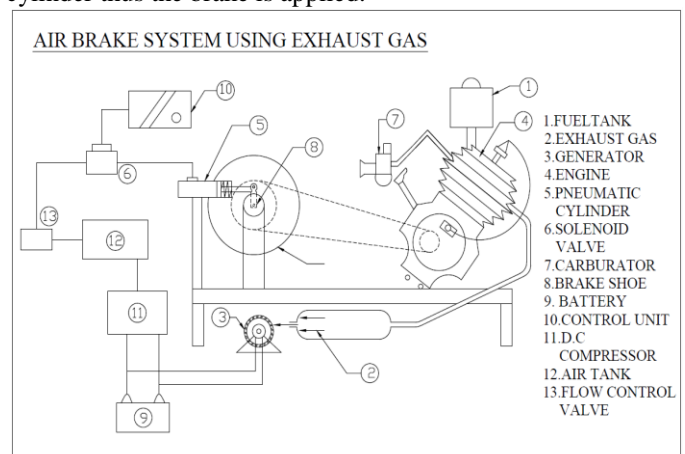

### V. CONCLUSIONS

In this project we have obtained a revolutionary process in the field of mechanical and automobile. Here the pneumatic cylinder is actuated by using the compressor that is powered by the electrical power generated from the engine's exhaust gas. This project has also reduced the cost involved in the

concern. It has been designed to perform the entire requirement task which has also been provided.

#### REFERENCES

- [1] Development of a model for an air brake system with leaks-SrivatsanRamarathnam (est.al)-2003
- [2] Pressure control scheme for air brakes in commercial vehicles -C.L. Bowlin (est.al)- Apr 2006
- [3] A new advanced power-generation system using chemical-looping combustion-Masaru Ishida Diesel engine exhaust gas recirculation-Ming Zheng (est.al)-2011
- [4] Power generation with gas turbine systems and combined heat and power-P.A Pilavachi-2004
- [5] Power generation using coir pith and wood derived producer gas in diesel engines-A.S. Ramadhas (est.al)
- [6] A Diagnostic System for Air Brakes in Commercial Vehicles-SwaroopDarbha -2009