

# PERFORMANCE ANALYSIS OF WAVY TWISTED TAPE INSERT FOR HEAT TRANSFER IN A CIRCULAR TUBE

N.B. Dhamane<sup>1</sup>, D.B. Nalawade<sup>2</sup>, M.M. Dange<sup>3</sup>

<sup>1</sup>M.M.I.T., <sup>2</sup>V.I.I.T., <sup>3</sup>G.S.M.C.O.E

Department of Mechanical Engineering

University of Pune

Maharashtra, India.

**Abstract:** *The present work shows the results obtained from experimental investigations of the augmentation of turbulent flow heat transfer in a horizontal tube by means of wavy twisted tape inserts with air as the working fluid. Experiments were carried out for plain tube with/without wavy twisted tape insert at constant wall heat flux and different mass flow rates. The wavy twisted tapes are of same pitch but three different wave-width of 13, 16 and 24 mm. The Reynolds number varied from 4000 to 9500. Both heat transfer coefficient and pressure drop are calculated and the results are compared with those of plain tube. It was found that the enhancement of heat transfer with wavy twisted tape inserts as compared to plain tube varied from 9% to 43% for various inserts. Also the results are compared with the plane twisted tape insert.*

**Keywords:** : *Wavy twisted tape insert, twist ratio, wave-width, Heat transfer Enhancement, Reynolds number.*

## I. INTRODUCTION

Among many techniques (both passive and active) investigated for augmentation of heat transfer rates inside circular tubes, a wide range of inserts have been utilized, particularly when turbulent flow is considered. A lot of methods are applied to increase thermal performance of heat transfer devices such as treated surfaces, rough surfaces, swirling flow devices, coiled tubes, and surface tension devices [1].

Twisted tape swirl turbulator is one of the commonly used passive types for heat transfer augmentation due to their advantages of steady performance, simple configurations and ease of installation [2]. These type inserts generate swirling flow and cause improved fluid mixing between central region and the nearly wall region so, the heat transfer in tubes can be enhanced by fluid mixing. Sarma et al. [3] gave generalized correlations to predict friction factor and convective heat transfer coefficient in a tube fitted with twisted tapes for a wide range of Reynolds number and Prandtl number. The contribution to thermal performance of the conventional, short-width and center-cleared twisted tapes was studied numerically [2]. Configuration optimization of regularly spaced short-length twisted tapes in a circular tube for turbulent heat transfer was carried out by Wang et al. [4] by using computational fluid dynamics (CFDs) modeling. Eiamsa-ard et al. [5] presented experimental study on convective heat transfer in a circular

tube with short-length twisted tapes inserted under uniform heat flux. Akhavan-Behabadi et al.

[6] conducted some experiments to analyse effects of twisted tapes on heat transfer enhancement and pressure drop in horizontal evaporators. They selected R-134a as working fluid. Heat transfer and friction factor of CuO/water nanofluid and water were experimentally investigated in circular tube equipped with modified twisted tapes has alternate axis [7-9]. Eiamsa-ard et al. [10] performed experimental works on heat transfer and friction factor characteristics in a double pipe heat exchanger fitted with twisted tape elements. They made their analysis for both continuously placed twisted tape and twisted tape placed with various free spaced in circular tube. The heat transfer augmentation and pressure drop during condensation of HFC-134a in a horizontal tube fitted with twisted tapes were experimentally analysed [11]. Jaisankar et al. [12] experimentally examined the heat transfer, friction factor and thermal performance caused by twisted tape for solar water heater. Twist ratio, space ratio, tape width, rod-diameter and phase angle effects on heat transfer and pressure drop were analysed experimentally in a circular tube fitted with regularly spaced twisted tape elements [13].

Naphon [14] also made experiments by using conventional twisted tape inserts in horizontal double pipe. Ferroni et al. [15] conducted some experiments in circular tube equipped with physically separated, multiple, short-length twisted tapes. Laminar convective heat transfer enhancement in twisted tape inserted tube was discussed experimentally by Sarma et al. [16]. In some studies, researchers focused the thermal effects of twisted tape inserts in modified tube instead of smooth tube, for example; Thianpong et al. [17] examined heat transfer enhancement in a dimpled tube with a twisted tape swirl generator inserted. They also presented the empirical correlations based on the experimental results of their study for prediction the Nusselt number and friction factor for Reynolds number from 12,000 to 44,000. Bharadwaj et al. [18] conducted experiments by using conventional type of twisted tapes to determine pressure drop and heat transfer characteristics of water in a 75-start spirally grooved tube. Some researchers [19] modified the conventional twisted tape geometries, for example; Murugesan et al. [20] used V-cut twisted tapes to analyse heat transfer and pressure drop in a circular tube.

## II. EXPERIMENTAL SET-UP

The schematic diagram of experimental set-up is given in Fig.1. The experimental facility includes a blower, an orificemeter to measure the volumetric flow rate, the heat transfer test tube (700 mm). The MS test tube 26 mm inner diameter (D1), 26.4 mm outer diameter (D2), and 2 mm thickness (t). The wavy twisted tapes are tested in this experiment, with three different wave-widths as 13,16 and 24 mm but have same twist ratio ( $y/D = 9.375$ ). They are fabricated from aluminium. Also one plane twisted tape made up of aluminium is tested. The schematic figure of the test tube with wavy twisted tape insert is given in Fig.2. The wavy twisted tapes contained in the experimental study are shown in Fig. 3. A 0.24 hp blower is used to force air through the test tube. Uniform heat flux is applied to external surface of the test tube by means of heating with electrical winding, whose output power is controlled by a variac transformer to supply constant heat flux along the entire section of the test tube. The outer surface of the test tube is well insulated with glass wool to reduce the convective heat loss to the surroundings. The external surface temperatures of the test tube wall are measured by 6 K-type thermocouples, which are placed on the outer wall of the test tube. Also, the inlet and outlet temperatures of the bulk air are measured by two K-type thermocouples at given points. An inclined manometer is used to measure pressure drop across the test tube.

After air passes the test tube, it enters to the orificemeter for determining volumetric flow rate readings. For this purpose a separate U-tube manometer is placed across orificemeter. The volumetric flow rate of air supplied from the blower is controlled by varying control valve position. The experiments are conducted by varying the flow rate in terms of Reynolds numbers from 4181 to 9466 of the bulk air. The test tube is heated from the external surface during the experiments, and the data of temperatures, volumetric flow rate, pressure drop of the bulk air and electrical output are recorded after the system is approached to the steady state condition. The Nusselt number, Reynolds number, friction factor, heat transfer enhancement are calculated based on the average outer wall temperatures and the inlet and outlet air temperatures.

## III. DATA COLLECTION AND ANALYSIS

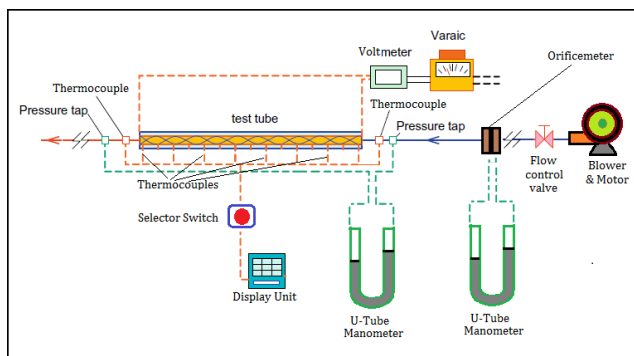

Figure 1: Experimental setup block diagram

The data reduction of the obtained results is summarized in the following procedures:

### A. Heat Transfer Calculations

$$T_s = (T_2 + T_3 + T_4 + T_5 + T_6 + T_7)/6 \quad (1)$$

$$T_b = (T_1 + T_8)/2 \quad (2)$$

$$\text{Equivalent height of air column, } = (\rho_w * h_w) / \rho_a \quad (3)$$

$$\text{Discharge of air, } Q_a = C_d * A_o \sqrt{2 * g * h_{air}} \quad (4)$$

$$\text{Velocity of air flow, } V = Q_a / A \quad (5)$$

$$\text{Reynolds number, } Re = VD/v \quad (6)$$

$$Q = m * C_p * (T_8 - T_1) \quad (7)$$

$$h = \frac{Q}{A(T_s - T_b)} \quad (8)$$

$$Nu_u = \frac{hD}{k} \quad (9)$$

$$f = \frac{\Delta P}{\frac{L}{D} * \frac{\rho_a V^2}{2}} \quad (10)$$

$$\eta = \frac{\frac{Nu_i}{Nu_u}}{\left(\frac{f_i}{f}\right)^{0.333}} \quad (11)$$



Figure 2: Schematic of test tube with wavy tape inserted

### B. Validation experiments of plain tube

In this study, experimental results of Nusselt number and friction factor for the plain tube are obtained and validated with equations of Dittus Boelter and Petukhov as given below;

$$Nu_{th} = 0.023 Re^{0.8} Pr^{0.4} \quad (12)$$

$$f_{th} = (1.82 \cdot \log_{10} Re - 1.64)^{-2} \quad (13)$$



Figure 3: Actual view of wavy twisted tape insert

The comparisons of Nusselt number and friction factor for the present plain tube with existing correlations are shown in Figs. 4 and 5, respectively.

These figures shows that validation experiments of heat transfer in terms of Nusselt number and friction factor for the plain tube are in good agreement with the results obtained

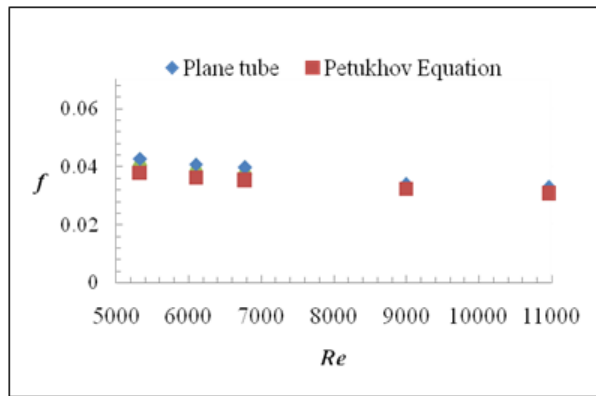

Figure 4: Validation results for friction factor

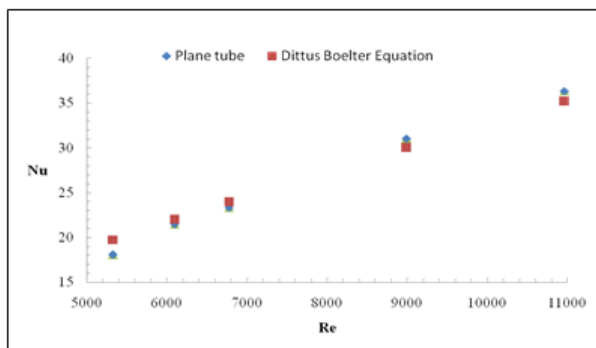

Figure 5: Validation results for Nusselt number

from Dittus-Boelter and Petukhov equations. The results of present plain tube and previous equations are nearly the same. Thus, this accuracy provides reliable results for heat transfer and friction factor in a tube with twisted tape inserts in this present study. The Reynolds number for validation test were ranged from 4500 to 11000 i.e. the range of Reynolds number used is for turbulent flow. Turbulent flow means Reynolds number greater than 4000. The results of the tests carried for performance checking of present wavy twisted tape are discussed further in results and discussion.

#### IV. RESULTS AND DISCUSSION

##### A. Heat Transfer and Overall Enhancement Characteristics

The variation of Nusselt number with Reynolds number for various wavy inserts is shown in Figure 6. Highest Nusselt number was obtained for tape with wave-width 13mm. The Nusselt number for wavy inserts varied from 32% to 87% compared to plain tube. This is due to strong turbulence intensity generated by corrugations on inserts leading to rapid mixing of the flow causing heat transfer enhancement.

The variations of friction factor with Reynolds number for wavy tape inserts are presented in Figure 7. It is

observed that the friction factor gradually reduced with rise in Reynolds number. It is observed to be maximum for insert having wave-width 13 mm. It is evident from Figures 6, 7 and 8 that when a wavy twisted tape is inserted into a plain tube there is a significant improvement in Nusselt number because of secondary flow, with greater enhancement being realized at lower Reynolds numbers and smaller wave-width for same twist ratio. This enhancement is mainly due to the centrifugal forces resulting from the spiral motion of the fluid and partly due to the tape acting as fin.

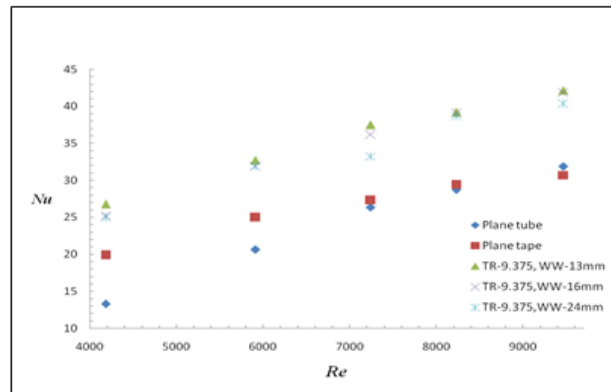

Figure 6: Variation of Nusselt number for different insert configurations

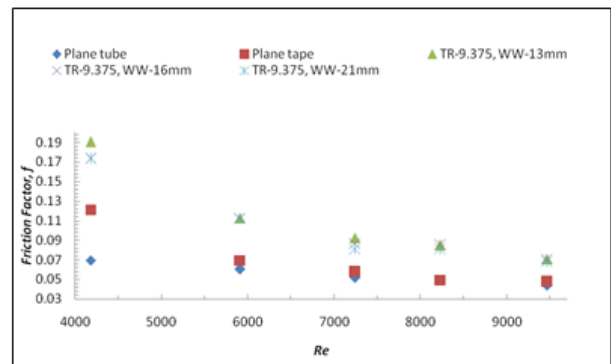

Figure 7: Variation of friction factor for different insert configurations

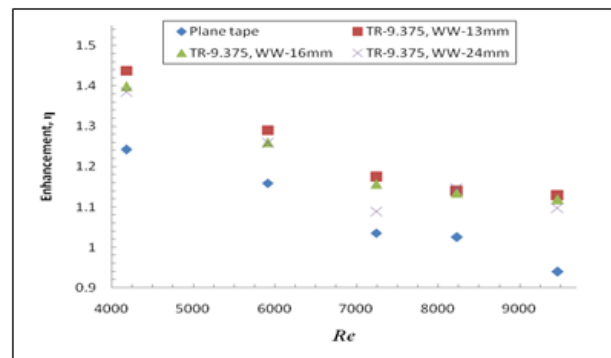

Figure 8: Variation of Enhancement for different insert configurations

It is observed that the reduction in wave-width causes increment in Nusselt numbers as well as rise in pressure drop. From Figure 6, the percentage rise in Nusselt numbers for wavy twisted tapes compared to plain tube are about 32- 98%, 31-89% and 26-87% respectively for tape with wave-widths of 13, 16 and 24 mm respectively for twist ratio =9.375. The overall enhancement ratio is useful to evaluate the quality of heat transfer enhancement obtained over plain tube at constant pumping power. It is found to be more than unity for all the wavy twisted tape inserts used.

Variations of overall enhancement ratio  $\eta$  against Reynolds number for various tapes are shown in figure 8. It is observed that overall enhancement tended to decrease gradually with the rise of Reynolds number for all twist ratios. The maximum value of overall enhancement is 1.43 for wavy twisted tape insert having wave-width of 13 mm with twist ratio equal to 9.375. It is seen in Figure 8 that, for tapes of wave-widths 13, 16 and 24 mm curves are of decreasing order for a given pitch in the range of Reynolds number from 4100 to 9400.

## V. CONCLUSIONS

The study presents an experimental investigation of the potential of wavy twisted tape inserts to enhance the rate of heat transfer in a horizontal circular tube with inside diameter 26 mm with air as working fluid. The Reynolds number varied from 4100 to 9400. The effects of parameters such as modified wave-width, Reynolds number on the heat transfer and overall enhancement ratio are studied.

The following conclusions can be drawn:

- A. The enhancement of heat transfer with wavy twisted tape inserts as compared to plain tube varied from 12 to 43% for wave width of 13 mm and 9 to 38% for wave-width 24 mm. This enhancement is mainly due to the centrifugal forces resulting from the spiral motion of the fluid.
- B. Reduction in tape width causes rise in Nusselt numbers as well as friction factors. The maximum friction factor rise was about 175% for 13mm and 150% for 24mm wave-width twisted tape inserts compared to plain tube.
- C. The overall enhancement for the tubes with wavy twisted tape inserts is 1.43 for wave-width 13 mm and 1.38 for wave-width-24mm wavy twisted tape insert.

Thus the enhanced performance can be achieved using wavy twisted tapes as compared to plane twisted tape. Thus, from the considerations of enhanced heat transfer and savings in pumping power wavy-width tape inserts are seen to be attractive for enhancing turbulent flow heat transfer in a horizontal circular tube.

Future work may be extended to:

- A. Change the tape material from Aluminium to Copper.
- B. Compound enhancement techniques maybe applied i.e., the tape inserts can be coupled with coil wire inserts for better enhancement.

## VI. NOMENCLATURE

- A0** - area of orifice, (m<sup>2</sup>)  
**A** - test section inner tube area, ( $\pi/4 D^2$ ) (m<sup>2</sup>)  
**C<sub>p</sub>** - specific heat of air, (J/kg K)  
**Q<sub>a</sub>** - air discharge through test section (m<sup>3</sup>/sec)  
**D** - Inner diameter of test section, (m)  
**H** - pitch, (mm)  
**w** - width of wavy tape insert,(mm)  
**H/D** - twist ratio  
**f<sub>th</sub>** - friction factor(theoretical) for plain tube  
**f** - friction factor(experimental) for plain tube  
**f<sub>i</sub>** - friction factor obtained using tape inserts  
**h** - experimental convective heat transfer coefficient, (W/m<sup>2</sup>K)  
**h<sub>w</sub>** - manometer level difference,(m)  
**hair** - equivalent height of air column, (m)  
**k** - thermal conductivity, (W/mK)  
**L** - length of test section, (m)  
**m** - mass flow rate of air, (Kg/sec)  
**N<sub>ui</sub>** - Nusselt number (experimental) with tape inserts, (hD/k)  
**N<sub>u</sub>** - Nusselt number (experimental) for plain tube  
**N<sub>uth</sub>** - Nusselt number for plain tube (theoretical)  
**P<sub>r</sub>** - Prandtl number  
**p** - pitch, (m)  
 $\Delta P$  - pressure drop across the test section, (Pa)  
**Q** - total heat transferred to air (W)  
**R<sub>e</sub>** - Reynolds number, ( $\rho V D/\mu$ )  
**T1, T8** - air temperature at inlet and outlet, (°K)  
**T2, T3, T4, T5** - tube wall temperatures, (°K)  
**T<sub>s</sub>** - average Surface temperature of the working fluid, (°K)  
**T<sub>b</sub>** - bulk temperature, (°K)  
**V** - air velocity through test section, (m/sec)

## VII. GREEK SYMBOLS

- v** - Kinematic viscosity of air, (m<sup>2</sup>/sec)  
 **$\mu$**  - dynamic viscosity, (kg/m s)  
 **$\eta$**  - Over all enhancement  
 **$\rho_w$**  - density of water, (Kg/m<sup>3</sup>)  
 **$\rho_a$**  - density of air (Kg/m<sup>3</sup>)

## REFERENCES

- [1] A.E. Bergles. ExHFT for fourth generation heat transfer technology. *Experimental Thermal and Fluid Science*, 26:335–344, 2002.
- [2] J. Guo, A. Fan, X. Zhang, and W. Liu. A numerical study on heat transfer and friction factor characteristics of laminar flow in a circular tube fitted with centercleared twisted tape. *International Journal of Thermal Sciences*, 50:1263–1270, 2011.
- [3] P.K. Sarma, P.S. Kishore, V. Dharma Rao, and T. Subrahmanyam. A combined approach to predict friction coefficients and convective heat transfer characteristics in

- A tube with twisted tape inserts for a wide range of Re and Pr. *International Journal of Thermal Sciences*, 44:393–398, 2005.
- [4] Y. Wang, M. Hou, X. Deng, L. Li, C. Huang, H. Huang, G. Zhang, C. Chen, and W. Huang. Configuration optimization of regularly spaced short-length twisted tape in a circular tube to enhance turbulent heat transfer using CFD modeling.
- [5] S. Eiamsa-ard, C. Thianpong, P. Eiamsa-ard, and P. Promvonge. Convective heat transfer in a circular tube with short-length twisted tape insert. *International Communications in Heat and Mass Transfer*, 36:365–371, 2009.
- [6] M.A. Akhavan-Behabadi, R. Kumar, A. Mohammadpour, and M. Jamali-Asthiani. Effect of twisted tape insert on heat transfer and pressure drop in horizontal evaporators for the flow of R-134a. *International Journal of Refrigeration*, 32:922–930, 2009.
- [7] K. Wongcharee, and S. Eiamsa-ard. Enhancement of heat transfer using CuO/water nanofluid and twisted tape with alternate axis. *International Communications in Heat and Mass Transfer*, 38:712–748, 2011.
- [8] K. Wongcharee, and S. Eiamsa-ard. Friction and heat transfer characteristics of laminar swirl flow through the round tubes inserted with alternate clockwise and counter-clockwise twisted-tapes. *International Communications in Heat and Mass Transfer*, 38:348–352, 2011.
- [9] S. Eiamsa-ard, and P. Promvonge. Performance assessment in a heat exchanger tube with alternate clockwise and counter-clockwise twisted-tape inserts. *International Journal of Heat and Mass Transfer*, 53:1364–1372, 2010.
- [10] S. Eiamsa-ard, C. Thianpong, and P. Promvonge. Experimental investigation of heat transfer and flow friction in a circular tube fitted with regularly spaced twisted tape elements. *International Communications in Heat and Mass Transfer*, 33:1225–1233, 2006.
- [11] V. Hejazi, M.A. Akhavan-Behabadi, and A. Afshari. Experimental investigation of twisted tape inserts performance on condensation heat transfer enhancement and pressure drop. *International Communications in Heat and Mass Transfer*, 37:1376–1387, 2010.
- [12] S. Jaisankar, T.K. Radhakrishnan, and K.N. Sheeba. Experimental studies on heat transfer and friction factor characteristics of forced circulation solar water heater system fitted with helical twisted tapes. *Solar Energy*, 83:1943–1952, 2009.
- [13] S.K. Saha, A. Dutta, and S.K. Dhal. Friction and heat transfer characteristics of laminar swirl flow through a circular tube fitted with regularly spaced twisted-tape elements. *International Journal of Heat and Mass Transfer*, 44:4211–4223, 2011.
- [14] P. Naphon. Heat transfer and pressure drop in the horizontal double pipes with and without twisted tape insert. *International Communications in Heat and Mass Transfer*, 33:166–175, 2006.
- [15] P. Ferroni, R.E. Block, N.E. Todreas, and A.E. Bergles. Experimental evaluation of pressure drop in round tubes provided with physically separated, multiple, short-length twisted tapes. *Experimental Thermal and Fluid Science*, 35:1357–1369, 2011.
- [16] P.K. Sarma, T. Subramanyam, P.S. Kishore, V.D. Raoc, and S. Kakac. Laminar convective heat transfer with twisted tape inserts in a tube. *International Journal of Thermal Sciences*, 42:821–828, 2003.
- [17] C. Thianpong, P. Eiamsa-ard, K. Wongcharee, and S. Eiamsa-ard. Compound heat transfer enhancement of a dimpled tube with a twisted tape swirl generator. *International Communications in Heat and Mass Transfer*, 36:698–704, 2009.
- [18] P. Bharadwaj, A.D. Khondge, and A.W. Date. Heat transfer and pressure drop in a spirally grooved tube with twisted tape insert. *International Journal of Heat and Mass Transfer*, 52:1938–1944, 2009.
- [19] S. Eiamsa-ard, P. Seemawute, and K. Wongcharee. Influences of peripherally-cut twisted tape insert on heat transfer and thermal performance characteristics in laminar and turbulent tube flows. *Experimental Thermal and Fluid Science*, 34:711–719, 2010.
- [20] P. Murugesan, K. Mayilsamy, S. Suresh, and P.S.S. Srinivasan. Heat transfer and pressure drop characteristics in a circular tube fitted with and without V-cut twisted tape insert. *International Communications in Heat and Mass Transfer*, 38:329–334, 2011.