

GSM BASED WATER BILLING MACHINE

Mrs. M.S.Vanjale¹, Namrata Dokre², Harshad Manekar³, Harshal Atwal⁴

Department of Electronics Engineering

AISSMS Institute of information technology, University of Pune
Pune, India.

Abstract: This proposed paper gives information about the design of a GSM based water billing system. This is achieved by using ATMEGA16 and GSM module. This paper details the practice for establishing a metering plan to account for usage and loss in the water distribution system. The bill amount will be sent to respective customers.
Keywords: GSM modem, ATMEGA16, Automated

I. INTRODUCTION

At present, most of the houses in India have the traditional mechanical meters and the billing system is not fully automated. As we all know today's water billing system involves conventional method in which a person from respective department comes and takes the photograph in their camera. These meter readings are used for water bill calculation and accordingly it is sent to the consumer's house by post. Sometimes the image is not clear, company is unable to send bill to respective customer or it has to repeat the entire process. An alternative, more practical, solution consists of reusing existing technologies that are already deployed in other fields, where the results are promising. The main idea is to customize existing solutions to the context of water billing and usage management.

II. RELATED WORK

Traditional meter reading for electricity consumption and billing is done by human operator from houses to houses and building to building. This requires huge number of labor operators and long working hour to achieve complete area data reading and billing. Human Operator billing are prone to reading error as sometimes as the houses meter is placed in a location where it is not easily accessible. Labor billing job is sometime also restricted and slowed down by bad weather condition. Printed billing has the tendency of losing the in mail box [1] Short Messaging Service (SMS) is an acknowledged method of textual communication supported by all GSM networks, and it has recently become an important transmission bearer for M2M communication [2]

A. EXISTING SYSTEM

In existing system, it has been observed that modifications are required as it has some problems in it. Some of these problems are as follows.

1. Many a times, more than one meter is allotted to the same person.
2. Misuse of water consumption.
3. Lot of paper work is involved in the billing process.
4. Not user friendly.
5. Bill generation process leads to more chaos.

III. PROPOSED SYSTEM

This paper details the design of billing machine which provides bill to the consumers through sms by using GSM module. A database is created which contains meter number, customer name, mobile number and previous 3 month's readings. Validation can also be done to prevent any malpractices in the existing system.

IV. HARDWARE

A. Block diagram

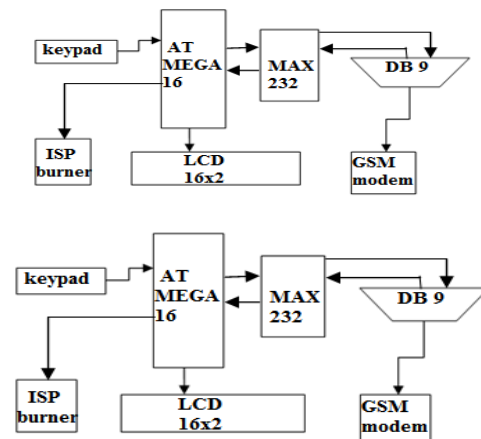

Fig. 1. GSM based water billing machine.

B. Description

1. Keypad: Meter reading is fed to controller as an input using keypad. Each key is assigned with a special character, digit or symbol. When a key is pressed, the respective assigned ASCII value of that key is provided to controller.
2. ATMEGA16: Controller unit receives the consumer's ID entered from keypad and compares it with the database present in the serial memory.
3. LCD: It's a 16x2 Liquid Crystal Display module, with 2 rows, each containing 16 characters.
4. MAX 232: It is a 16 pin driver IC which is used for serial communication between controller and GSM module through DB9 connector.
5. DB 9: It's a 9 pin connector connected to MAX 232 module.
6. GSM module: GSM (Global System for Mobile communication) is a digital mobile telephony system. With the help of GSM module interfaced,

short text messages can be sent to the required consumers. This technology enables the system a wireless system with no specified range limits. GSM uses a variation of time division multiple access (TDMA) and is the most widely used of the three digital wireless telephony technologies (TDMA, GSM, and CDMA). It operates at either 900MHz or 1800 MHz frequency band. GSM modem plays a very important role.

C. Working

It is necessary to describe the proper sequence of events or operations which helps to run the system in successful manner. These statements describe in brief what must happen in the system and in what way to achieve the required result. The steps involved in this paper are as follows:

1. The office person enters respective consumer's ID using keypad to check his details such as consumer's name and his previous records which will be displayed on LCD.
2. He then notes the meter reading from user's meter and enters that value on machine using keypad.
3. According to the entered value, Controller calculates billing amount using inbuilt program.
4. This billing amount is then sent over to GSM modem with the help of MAX232 and DB9 connector using serial communication.
5. GSM modem uses AT commands to send this calculated bill amount as sms to that customer as well as to the main office for future reference.

V. SOFTWARE

STEP 1:

- a) Consumer's ID is entered through keypad.
- b) After inserting the ID, it will check if the given ID is a valid ID or not.
- c) If NO, it will display as INVALID USER on LCD.
- d) If YES, a message will be display on LCD as a VALID USER.
- e) A reading as per the meter is then entered with the help of keypad.
- f) According to the entered value, Controller calculates billing amount, by multiplying the reading by 10.
- g) The multiplied factor is the amount of bill, will be send to consumer's mobile as sms.

STEP 2: GSM modem

- a) GSM modem uses AT Commands to send sms.
- b) The multiplied factor is the amount of bill.
- c) GSM modem uses AT command,"AT+CMGF" to send amount of bill as sms on a respective consumer's mobile.

A. Flowchart

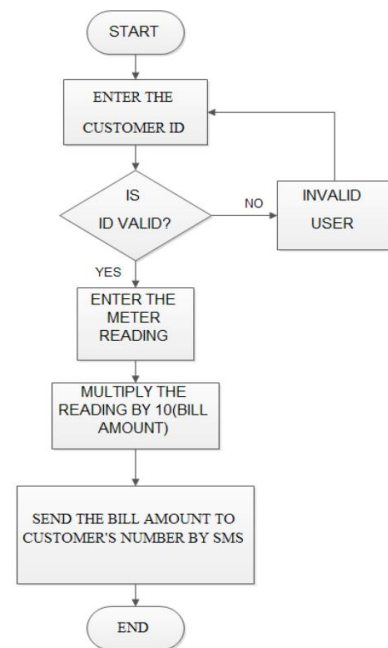

VI. CONCLUSION

The system designed provides accurate bills. It is cheap, so it is affordable. The present system is superior in both performance and operation. Moreover, it has overcome the problems faced by the existing system. Thus desired requirement is fulfilled by this system.

VII. ACKNOWLEDGEMENT

I am grateful to Mrs. M.S. Vanjale Department of Electronics Engineering and all staff members for their innovative thinking, continuous guidance, genius role and encouragement throughout the whole project period.

REFERENCE

- [1] HG Rodney Tan, C H Lee, V H Mok, "Automatic Power Meter Reading System using GSM network, "Engineering in Medicine and Biology Society, 1996.
- [2] Beena Joy Chirayil, "Facilitating Machine to Machine (M2M) communication using GSM Network", Intel Comneon GmbH, Nuremberg, Germany.