

# WASTE SEGREGATION USING PROGRAMMABLE LOGIC CONTROLLER

S.M .Dudhal<sup>1</sup>, B. S. Jonwal<sup>2</sup>, Prof. H. P. Chaudhari<sup>3</sup>  
Department of Instrumentation and Control Engineering  
AISSMS Institute of Information Technology  
Pune, India.

**Abstract:-** This paper describes an Automated Waste Segregation; we are developing a prototype for separating out metals from waste materials using Programmable Logic Controller. In this system the waste will be fed to the conveyor belt through an automatic feed system which will comprise of a hopper and other mechanism. Sensors will detect the waste material on the conveyor belt and start the rotation of conveyor belt. After this, metal Sensors which are clamped below the conveyor belt, will sense the metal particles and in turn stop the conveyor belt. A robotic arm to which an electromagnet is attached will extract the metal from the waste and will deposit it into a bin. The waste material will be carried on further once the metal is extracted and dumped into a waste bin.

## I. INTRODUCTION

There has been a significant increase in Municipal Solid Waste (MSW) generation in the last few decades. Due to rapid urbanization and uncontrolled growth rate of population municipal solid waste management has become acute in India. The environmental problem arising from unscientific and indiscriminate disposal of municipal garbage is a real menace for the whole society. As per the previous data in India per capital waste generation had increased by 1.3percent annually with urban population increasing between 3 3.5 percent per Annam. Yearly increase in waste generation is around 5percent. In India the municipal agencies spend 5-25percent of their budget on SWM. Unfortunately, high capital investment in the solid waste management sector does not necessarily lead to improvements in the quality of service. Untreated/raw open dumping of municipal solid waste is common picture in India which may cost several environmental and public health problems. Landfills are also becoming increasingly expensive because of the rising costs of construction and operation. Incineration, which can greatly reduce the amount of incoming municipal solid waste produce ash which contain hazardous materials including heavy metals and organic compounds such as dioxins. Recycling and Recovery (treatment/processing) plays a large role in solid waste management. The purpose of this project is to segregate the metal particles from the industrial and municipal waste. Due to the environmental aspect as well as increasing prices for raw and recyclable materials, waste separation is a global topic and also the business model of the future. The

advantages of waste separation systems lie in the modular design, which allows for any required short-term adjustments to the capacity level. The attributes “affordable and high quality” are characteristic for waste sorting systems and waste separation systems. Improved control (in general) results in energy savings, safety improvements, better environmental performance and consistent product quality, minimizes raw materials wastage and reduces manufacturing costs. All of these benefits may be categorized as improved waste management. Every waste separation system can be used flexibly. Waste separation systems can be put in use for local communities, private investors, industry and commerce. The stress of competition forces companies to produce economically and rationally. A higher level of automation demands more and more programmable logic controllers (PLC). The advantage of PLC is the automation with a relatively small amount of cabling and a low error rate. Productivity, flexibility and efficiency with only a few contactors (heavy duty relay) specify the controller. The system is completed by modifications and extensions of functions (without mechanical intervention) as well as by communication with other devices via analog, digital and serial interfaces. With programmable logic controllers, processes can be monitored and operated via a PC.

## II. DESIGN CONSIDERATION

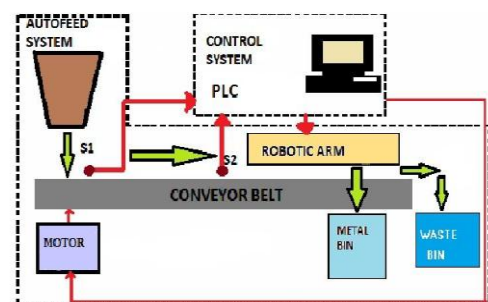

This deals with the work flow of the total system from beginning till the end. As mentioned earlier, different modules have to be interconnected in such a way that they function in a proper sequence in a desired manner.

1. Sensors: Object sensor is used to detect whether the waste is given through the feeder.
2. PLC, Computer and power supply for PLC: To take action on input and output as per program logic feed to PLC.

3. Action performing components: It contains rotating con-veyor belt (which starts rotating when the feed is given to it and stops for a predefined time when any metal is detected).It also contains robotic arm (which starts its movement when metal is detected and conveyor belt stops).

### III. SYSTEM ARCHITECTURE

Flowchart of the system:

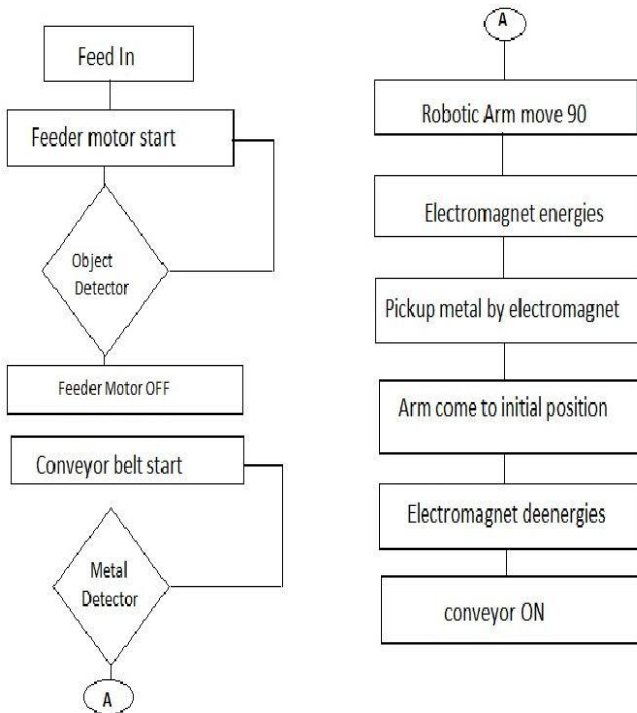

The main components of the system are as follows:

#### A. Auto Feeder:

The auto feeder will feed the waste material onto the conveyor belt. If there is no material in the hopper, which we are using for auto feed mechanism, then the feeder alarm will go on process will come to a halt.

#### B. Object sensor:

The objective of the object sensor is used to detect the presence of the object on the conveyor belt. When the object is detected the sensor will signal the PLC to start the conveyor. An inductive sensor is an electronic proximity sensor, which detects metallic objects without touching them. The sensor consists of an induction loop.

Electric current generates a magnetic field, which collapses generating a current that falls asymptotically toward zero from its initial level when the input electricity ceases. The inductance of the loop changes according to the material inside it and since metals are much more effective inductors than other materials the presence of metal increases the current flowing through the loop. This change can be

detected by sensing circuitry, which can signal to some other device whenever metal is detected.

The advantages of inductive proximity sensors are

- They are very accurate compared to other technologies
- Have high switching rate
- Can work in harsh environmental conditions

#### C. Robotic Arm:

Robotic arm delivers fast, accurate, and repeatable movement. The robot features: base rotation, single plane shoulder. The aluminum robotic arm is made from our Servo Set components for the ultimate in flexibility and expandability. This kit consists of aluminum brackets, Aluminum tubing and hubs, wheels, and electromagnet. When the metal is detected by the metal detector the conveyor belt stops. Control signal is given to Robotic Arm by PLC to extract the metal by the electromagnet attached to it and then turn around 180 degrees and drop the metal particles into a bin.

#### D. Conveyor Belt:

The system consists of conveyor belt with object sensors clamped on it. The material passes over the conveyor and metal present it is extracted with the help of robotic arm.

#### E. PLC:

The PLC controls the final control elements. The main function of the PLC is acquire the digital and analog data from input module and vary the output of the system as the input conditions change, this is necessary as the system designed is a real time system. The PLC is programmed such that it will vary the output of the system if there is any change in the input quantity

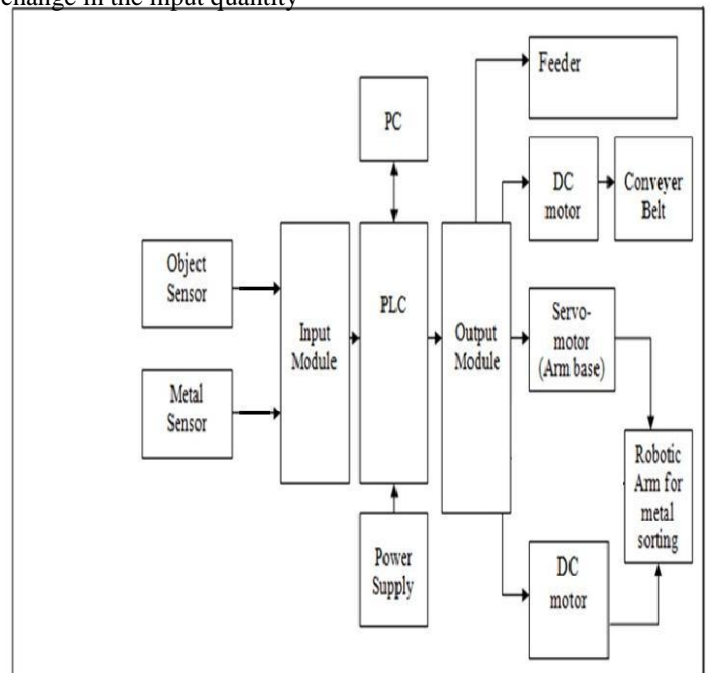

#### IV. CONCLUSION

Automated waste segregation is largely implemented in various industries, taking into consideration various factors such as reduction in manpower, avoid risk at hazardous places, improve accuracy, increase speed of production, etc.

#### REFERENCES

1. John W Carson Greg Petro, How to design reliable and efficient feeders for Bulk Solid Bulk conveyors for bulk materials, Second edition, conveyor equipment manufacturers association (CEMA).
2. Jon Webb, Programmable Logic Controllers: Principle and Application, Merrill, 1992.
3. S. K. Singh, Industrial Instrumentation and control; 3rd edition, 2009.
4. C.D Johnson, Process Control Instrumentation Technology, John Wiley Sons Inc. 3rd edition, 1998.
5. Bela G. Liptak, 'Process Control-Handbook', Radnor, Pennsylvania 1995.
6. SITES REFERRED:
  - [www.br-automation.com](http://www.br-automation.com)
  - [www.alldatasheets.com](http://www.alldatasheets.com)
  - [www.futuronix.in/industrial-projects.html](http://www.futuronix.in/industrial-projects.html)