

DIGITAL CAPACITIVE TEMPERATURE SENSOR

Mr Amol R. Marlapalle¹, Mr Aditya R. Gath², Mr Nikhil B. Rakibe³, Prof. Amita A. Shinde⁴
Department of Instrumentation and Control Engineering
AISSMS's Institute of Information Technology, Pune, India.

Abstract: - We are designing this system to provide accurate and low cost solutions for the measurement of temperature. This proposed system explains frequency variation of the oscillator circuit according to the change in the value of capacitance due to temperature. The capacitor (1nF) used as a temperature sensing element. A series resonant oscillator circuit is built using NAND gates. In series resonant oscillator circuit, oscillations are dependent on the series capacitance (1nF). Effect of temperature on small value (1nF) capacitor, which changes output frequency of series resonant circuit. We are using NAND gate IC (4093) which consists of four Schmitt trigger circuits. We are using microcontroller (p89v51rd2) for the measurement of frequency signals and LCD display for displaying measured frequency.

Index Terms: - Ceramic Capacitor (1nF), CD4093 NAND IC, P89v51rd2 Microcontroller ISP-In System Programmer, 16*2 LCD Display.

I. INTRODUCTION

It is well known that, Thermocouple, Thermistor and Resistance thermometer (RTD) are widely used for temperature measurement. Though it is possible to have similar temperature coefficient CAPACITOR. While making a survey it was found that only one company (Lake-Shore) uses capacitance phenomenon, as one of the element in their costly multisensory instrument. They have used a capacitance, specifying that it can be used as a temperature sensor in the strong magnetic field. Details or any other specifications are not discussed. There we jump over an idea of a very low cost digital (Frequency output) capacitor temperature sensor. The series resonant oscillator circuit sustains its oscillations by precise choice of capacitor which is near ground as shown in fig 2. At a last we have used a ceramic capacitor (grounded) of 1nF, for an oscillator circuit. The capacitance of a capacitor varies with the temperature. Unlike other temperature sensors (e.g. LM 35, RTD), this sensor doesn't require an ADC or other digitizing circuit for interface.

II. DESIGN CONSIDERATION

The Block Diagram of Proposed system is as shown in figure 1. It consists of:

- Ceramic Capacitor.
- NAND IC.
- Microcontroller.
- LCD.

In this system we are using series resonant oscillator circuit for the generation of frequency signal. The output frequency of series resonant oscillator circuit changes due to change in value of capacitor 1nF (Grounded) as shown in fig 2. The main components of the system are as follows:

A. Capacitor:

A capacitor consists of two metal plates with a thin insulator in between. The capacitance depends on the size of the plates and the material between them. This material is called the dielectric and reduces the electric field between the plates. This will increase the capacitance. The capacitance can be calculated, $C = \epsilon A/d$ Where, ϵ = Dielectric constant, A= The area of one plate and d= The distance between the plates. The unit of capacity is Farad, symbol F. When the voltage across a certain resistor increases, the current flow through that resistor will also increase (and visa versa). This is not true for a capacitor. We already saw in the introduction that if a capacitor is fully charged (so the voltage across it has reached its maximum), the current flow stops. The current will have its maximum value when the capacitor is empty. There are generally two types of capacitors:

- Polarized (Electrolytic)
- Bipolar (Ceramic).

Polarized capacitors have a positive and a negative terminal; bipolar capacitors don't.

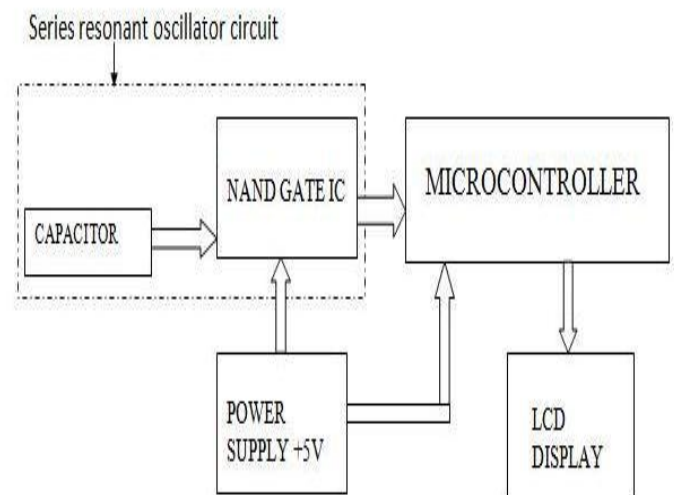

Fig. 1: Block diagram

B. NAND IC:

The CD4093 consists of four Schmitt-trigger circuits. Each circuit functions as a 2-input NAND gate with Schmitt-trigger action on both inputs. The gate switches at different points for positive and negative-going signals. The difference between the positive and the negative voltage is defined as hysteresis voltage (VH).

Features:

- Wide supply voltage range 3.0V to 15V.
- Schmitt-trigger on each input with no external components.
- Noise immunity greater than 50
- Equal source and sink currents.
- No limit on input rise and fall time.
- Operates across the automotive temperature range from 40 deg C to + 125C:

Applications:

- Wave and pulse shapers.
- High-noise-environment systems.
- Monostable multivibrators.
- Astable multivibrators.
- NAND logic.

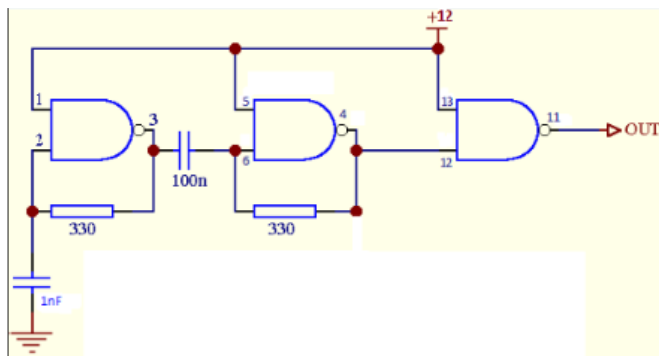

Fig. 2: Circuit Diagram

C. Microcontroller:

The P89V51RD2 is an 80C51 microcontroller with 64 kb Flash and 1024 bytes of data RAM. A key feature of the P89V51RD2 is its X2 mode option. The circuit designer can choose to run the application with the conventional 80C51 clock rate (12 clocks per machine cycle) or select the X2 mode (6 clocks per machine cycle) to achieve twice the throughput at the same clock frequency. Another way to benefit from this feature is to keep the same performance by reducing the clock frequency by half, thus dramatically reducing the EMI. The Flash program memory supports both parallel programming and in serial In-System Programming (ISP). Parallel programming mode offers gang-programming at high speed, reducing programming costs and time to market. ISP allows a device to be reprogrammed in the end product under software control. The P89V51RD2 is also In-Application Programmable (IAP), allowing the Flash program memory to be reconfigured even while the application is running.

Features:

- 5 V Operating voltages from 0 to 40 MHz
- 64 kb of on-chip Flash program memory with ISP (In-System Programming) and IAP (In-Application Programming).
- Supports 12-clock (default) or 6-clock mode selection via software or ISP.
- Four 8-bit I/O ports with three high-current Port 1 pins (16 mA each) and three 16-bit timers/counters.
- Programmable Watchdog timer (WDT).
- Eight interrupt sources with four priority levels.
- Power-down mode with external interrupt wake-up.
- SPI (Serial Peripheral Interface) and enhanced UART.
- TTL- and CMOS-compatible logic levels.
- Second DPTR register and low EMI mode (ALE inhibits).
- PCA (Programmable Counter Array) with PWM and Capture/Compare functions.

D. LCD Display:

The LCD display is used to display frequency signals from Microcontroller.

	A(X)	B(Y)	C(Y)
Long Name	Temperature	Heating	Cooling
Units	°C	khz	
Comments			
1	30	230.22	230.22
2	40	230.52	235.42
3	50	230.71	245.32
4	60	232.57	268.45
5	70	248.5	299.17
6	80	264.72	335.75
7	90	287.8	377.22
8	100	311.59	418.36
9	110	338.62	457.68
10	120	373.43	497.73
11	130	407.34	535.81
12	140	453.53	571.47
13	150	486.76	605.9
14	160	527.28	638.72
15	170	565.95	669.7
16	180	604.04	692.04
17	190	645.96	710.21
18	200	701.87	712.1

Fig. 3: Observation Table

III. WORKING

As shown in figure 2, a series resonant oscillator circuit using the NAND Schmitt trigger IC is built. Capacitor so as to produce the oscillation which will depend upon change in temperature. The capacitor (1nF) plays important role in this circuit. Rise in temperature (30c to 200c) near the ceramic capacitor, changes the frequency of oscillation at the output. In series resonant oscillator circuit, oscillations are dependent on the series capacitance (1nF). As temperature varies from 30c to 200c, there is a linear frequency variation from 200 KHz to 712 KHz. In ceramic capacitors the ceramic dielectric is characterized by a linear change of capacitance over the temperature range. Change in capacitance of ceramic capacitor due to temperature used as a temperature

sensor. The frequency signals from the series resonant oscillator circuit are then fed to microcontroller for measurement of frequency signals. The measured frequency signals are then displayed on LCD display.

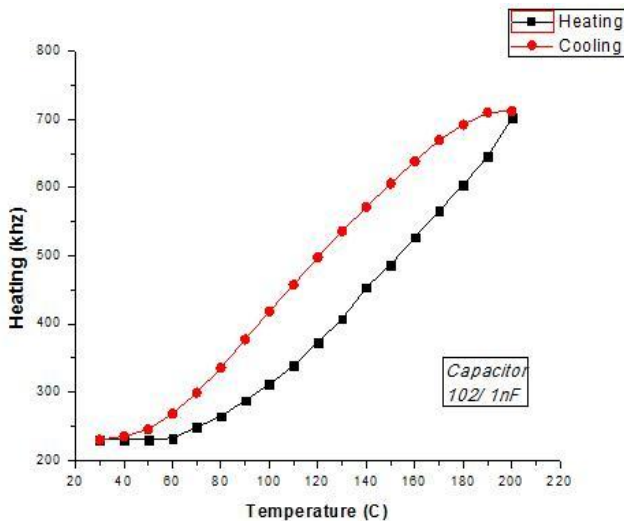

IV. APPLICATION

- IC fabrication Industry.
- Automotive Industry.
- Process Automation.
- Every industry where temperature measurement is required.

V. RESULT

As shown in the figure 4, when the temperature varies in the range of 30c to 200c, a linear change in the frequency of oscillations in the series resonant oscillator circuit is observed. There was no error significantly observed in a single cycle (heat and cool) with our present calibration system. Repeated heating and cooling cycle also gives the same trend hence the observed hysteresis may be possible due to only testing and calibration system.

VI. CONCLUSION

Unlike other temperature sensors (e.g. LM 35, RTD), this sensor directly give digital output. Presently, available sensors do not give the output directly in digital form and hence need ADC. This type of sensor is cost effective and reliable. The reliability of digital capacitive sensor depends upon the dielectric constant of ceramic capacitor. Any commercial available ceramic capacitor as discussed above can be used as a sensor for digital capacitive temperature sensor, with the provision that the capacitance value is first tested in the laboratory.

REFERENCES

- [1] Muhammad Ali Mazidi and Janice Gillispe Mazidi, "The 8051 micro-controller and embedded systems" Pearson

education Ltd, India, 2004.

- [2] 2013 Lake Shore Cryotronics, Inc. (www.lakeshore.com).
- [3] LM35 Precision Centigrade Temperature Sensors, TEXAS INSTRUMENTS, www.ti.com
- [4] Thomos scherrer Crystal Oscillator circuits.
- [5] www.keil.com/arm.