

# ANTICOLLISION OF CARS

Kshitija Markale<sup>1</sup>, Sagar Swami<sup>2</sup>  
Instrumentation and control  
AISSMS IOIT

**Abstract:** The wireless communication technologies enabled vehicles on highway to communicate, in order to share information and information to avoid collision. The vehicle state information is being obtained using ultrasonic sensors, to predict potential accident and accordingly reduces the vehicle speed. This protocol provides warning message when the safety distance is reduces than the safety limit. Here, the car will be equipped with an ultrasonic sensor which will continuously track for any obstacles from the front side. If the obstacle is detected then the microcontroller will continuously compare the distance given by the ultrasonic sensor. If distance goes on reducing indicating that the front car is coming closer to the current car then the microcontroller will start applying brakes until the distance is within safe limit. ZigBee is used for signal detection in order to lower car speed as it receives the signal from another ZigBee mounted at the traffic signal unit.

## I. INTRODUCTION

### A. Information about the system:

In India 14 people die every hour as inspected by times of India. The main cause of accident is breaking of traffic rules. Though many rules has been laid down no one follows the traffic rules. Accidents take place due to signal breaking, overtaking and crossing of lanes. Hence we have used ultrasonic sensor and ZigBee. Ultrasonic sensors have been used in order to measure safe distance between two cars. ZigBee is used for signal detection in order to lower the car speed as it comes in the range of another ZigBee mounted at the signal. The emphasis has been laid on anti-collision of cars maintaining distance between two cars and overtaking of cars. The discipline and following of traffic rules will help us to improve the traffic system.

### B. Overview of the target for the final system

This system is mostly executed in cities as it involves measures such as breaking of signal, overtaking etc. It can also be employed on highways with ultrasonic sensor. The ultrasonic sensor continuously sends RF signal as an obstacle comes in its way the signal gets cut and car comes to halt. It can also be used on toll plaza where speed control is necessary and maintenance of safe distance is mere importance.

## II. OBSTACLE AVOIDANCE

### A. Ultrasonic Sensor:

Its compact size, higher range and easy usability make it a handy sensor for distance measurement and mapping. Ultrasonic sensors are basically used to measure the distances between the obstacle / object and the sensor. The ultrasonic

sensor works on Doppler Effect. It consists of ultrasonic transmitter and a receiver. The transmitter transmits the signal in one direction. This transmitted signal is then reflected back by the obstacle and received by the receiver. So the total time taken by the signal to get transmitted and to received back will be used to calculate the distance between the ultrasonic sensor and the obstacle. Here we are added an application that is four Emergency keys. Actually these keys are like if we want ambulance service than first key will be pressed than by the use of zigbee transmission the messages will be passed to the near vehicles.

## III. SPEED CONTROL

### A. Driver IC L293D:

The Device is a monolithic integrated high voltage, high current four channel driver designed to accept standard DTL or TTL logic levels and drive inductive loads (such as relays solenoids, DC and stepping motors) and switching power transistors. To simplify use as two bridges each pair of channels is equipped with an enable input. A separate supply input is provided for the logic, allowing operation at a lower voltage and internal clamp diodes are included. This device is suitable for use in switching applications at frequencies up to 5 kHz .The L293D is assembled in a 16 lead plastic package which has 4 center pins connected together and used for heat sinking. The L293DD is assembled in a 20 lead surface mount which has 8 center pins connected together and used for heat sinking

## IV. ARM DC MOTOR INTERFACE

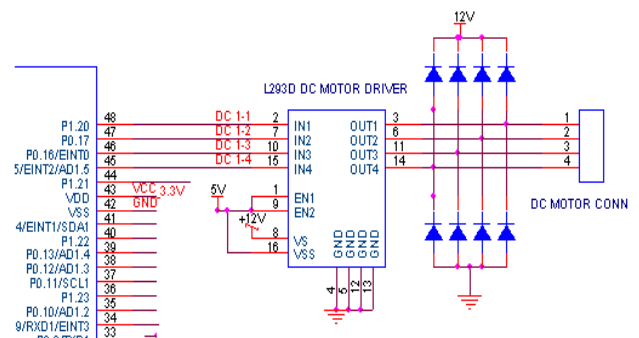

Here in our project we are using a 12v DC motor which is Bipolar, which means that the DC motor can rotate both the sides .For this we are using a DC motor driver IC L293D.This driver IC can drive 2 DC motors. In our project we are connecting only 1 DC motor so we are connecting only the 1st pair of the DC motor.(in1 and in2 of L293D).The DC motor will be connected at OUT1 and OUT2 of L293D respectively.

#### A. FREEWHEELING DIODES:

Here we are interfacing a 8 diodes at the o/p side of DC motor. Here whenever the DC motor changes the polarity back EMF is generated which can damage the DC motor. So the freewheeling diodes ground the extra energy through ground .Whenever the Back EMF is generated which is freewheeled to ground which keeps the DC motor safe.

### V. RESULT ANALYSIS

#### A. Signal Detection:

The car comes to halt when there is signal communication between two ZigBee, with one mounted on the signaling unit and other in the car. Here a DC motor based BUGGY is used. The micro-controller will increase and reduce DC speed control via pulse width modulation. The micro controller will increase or decrease ON time and OFF time of the entire pulse time. If we decrease the ON time then the voltage applied to the DC motor will reduce and the speed of the DC motor will be reduced.

#### B. Anti-collision of cars:

The CARS can communicate about the current speed. The speed of the CAR in front of the car is constantly monitoring the speed. If the speed decreases suddenly the car behind comes to know about it instantly and the breaks are applied avoiding a possible accident. The cars can also communicate about the traffic condition, Weather condition etc. Ultrasonic sensor: Ultrasonic sensors (also known as transceivers when they both send and receive, but more generally called transducers) work on a principle similar to radar or sonar which evaluates attributes of target by interpreting the echoes from radio or sound waves respectively. Ultrasonic sensor generates high frequency sound waves and evaluates the echo which is received back by the sensor. Sensors calculate the time interval between sending the signal and receiving the echo to determine the distance to an object. This technology is used for measuring the distance. ZigBee range is 30m. Practically it gives 25m, this range operates even with obstacle. As it exceeds 25m range it does not work properly.

### VI. Conclusion:

Thus, we have discussed many issues pertaining to the communication protocols. That uses sensor information to avoid potential accidents. The system also useful in giving warning signals with continuous tracking of front-side obstacles. The ZigBee used in this project communicates at a distance of 30m, but practically it is working in the range of 25m. Future scope: Real time implementation possible.

Can be used in cars for anti-collision

### REFERENCES

- [1] Huang Zhu, Gurdip Singh, "A Communication Protocol for a Vehicle Collision Warning System",2010 IEEE International Conference on Green Computing and Communications & 2010 IEEE International Conference on Cyber, Physical and Social Computing,2010.
- [2] Nobuyoshi Mutoh, Yusuke Sasaki, "A Driver

Assisting System for Eco-Vehicles with Motor Drive Systems Which Avoids Collision with Running Vehicles by Using Inter-Vehicle Communications", proceedings of the 2007 IEEE Intelligent Transportation Systems

- [3] Conference Seattle, WA, USA, Sept. 30 - Oct. 3, 2007.
- [4] Ramakant Gaikwad, "Op-amp and linear integrated circuits." 4th edition, Pearson publications.
- [5] A.K.Sahwney. Course in Electrical and Electronics measurement and Instrumentation, 17th edition Dhanpatrai and Company.