

# SPEED SENSORLESS CONTROL OF BLDC MOTOR USING ADAPTIVE FUZZY INFERENCE SYSTEM

G.Kaviyarasu<sup>1</sup>, R.Manoj Kumar<sup>2</sup>, P.Arulmani<sup>3</sup>

Department of Electrical and Electronics Engineering

<sup>1</sup>GCE-Tirunelveli, <sup>2</sup>Nandha Engineering College-Erode, <sup>3</sup>Thangavelu Engineering College- Chennai

**Abstract:** In this paper sensorless control of BLDC Motor is investigated. In conventional control, it is generally required to measure the speed and position of rotor by using the sensors because the inverter phases, acting at any time, must be commutated depending on the rotor position. This paper introduces Artificial Neural Networks (ANNs) for estimating speed and ANFIS for controlling the BLDC motor. Therefore, ANFIS uses a combination of least squares estimation and back propagation to minimize the Error. The validity of the proposed approach is shown through simulation.

**Keywords:** artificial neural networks, Sensorless, ANFIS, BLDC Motor.

## I. INTRODUCTION

Brushless Direct Current (BLDC) motors are used in a wide variety of fields due to their high efficiency, high startup moment and silent operation. To operate brushless DC motors, a control system and sensors that determine rotor position are required. Systems that can be controlled without sensors were developed due to advances in technology. A brushless direct current (BLDC) motor provides commutation operation electronically instead of mechanically. In brushed DC motors, electric conduction to the windings in the rotor is provided via a brush-collector structure. Due to the sectional structure of the collector mechanism, the direction of the current passing through the rotor windings automatically changes while the motor turns. This system creates some problems, including formation of sparks, servicing requirements and wear in brushes. In brushless direct current motors, the function of the brush-collector mechanism is undertaken by a controller. The controller includes semi-conductive circuit components that serve to switch high current and adjusts the timing of the switching. To avoid any disruption in the rotation of the motor, the controller should follow the rotor at an appropriate speed. For this operation, the rotor position should be known.

## II. SPEED ESTIMATION USING ARTIFICIAL NEURAL NETWORK

ANNs have an extensive range of applications in real life problems. They are currently used successfully in many industries. There is no restriction in the fields of application; however they are more heavily used in fields such as estimation, modeling and classification. In this paper motor speed(rpm) of a brushless direct current motor is determined using an artificial neural network. ANNs are mathematical systems consisting of many weighted interconnected

operation elements (neurons). This processing element receives signals from other neurons; combines and converts them; and produces a numerical result. In general, processing elements roughly correspond to real neurons, they are interconnected via a network and this structure constitutes neural networks. The data set used to train the model. In the data set has terminal voltage, armature current and speed. Today there are many ANN models that are applied to different problems. The most common model is the multilayer perceptron model, trained with a back propagation learning algorithm. The “Levenberg-Marquardt learning algorithm” was used as the back-propagation learning algorithm to train the ANN model. Once the network is trained, an ANN can be operated with new data and estimations can be produced. The performance of a network is measured by the aimed signal and error criterion. The error margin is obtained by the comparison of the output of the network and the aimed output. A back-propagation algorithm is used to adjust the weights in such a way to reduce the error margin. The network is trained by repeating this processing many times. The aim of training is to reach an optimum solution based on performance measurements.

## III. ANFIS CONTROLLER

ANFIS is a fuzzy inference system based on Takagi-Sugeno model and this system uses given input and output data set to build fuzzy inference system. To start the ANFIS learning; first, a training data set that contains the desired input/output data pairs of target systems to be modeled is required. The design parameters required for any ANFIS controller are number of data pairs, training data sets, checking data sets, fuzzy inference systems for training, number of epochs to be chosen to start the training, learning results to be verified after mentioning the step size.

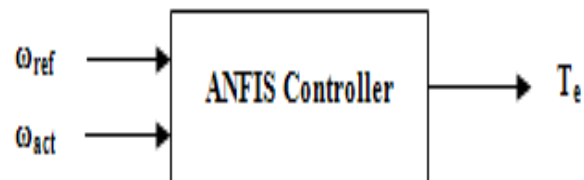

Fig.1. Logic of ANFIS controller

Logic of ANFIS controller is shown in Fig. 2. The designed ANFIS has two inputs namely, the actual motor speed and reference speed while the output is the torque, which is used to generate current. Here bell shaped membership function is used.

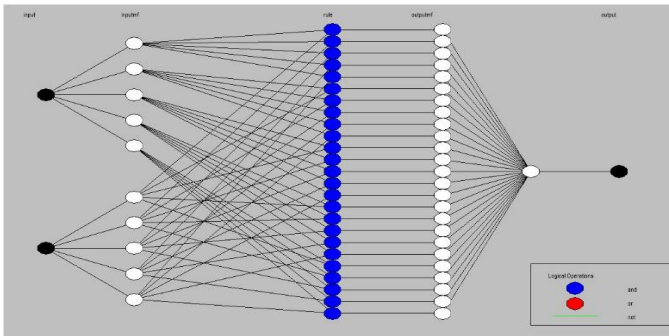

Fig.2. Structure of ANFIS speed controller

Structure of ANFIS speed controller is shown in Fig.2. It is a five-layer feedforward fuzzy neural network. Every layer has its definite meaning.

**Layer 1: (Input Layer)** Input layer represents input variables of controller, they are speed error and its error rate ratio referred as  $x_1$ ,  $x_2$  respectively. This layer just supplies the input values  $x_i$  to the next layer, where  $i = 1$  to  $n$ .

**Layer 2: (Fuzzification Layer)** This layer (membership layer) checks for the weights of each membership functions (MFs). It receives the input values from the 1st layer and act as MFs to represent the fuzzy sets of the respective input variables. Further, it computes the membership values which specify the degree to which the input value  $x_i$  belongs to the fuzzy set, which acts as the inputs to the next layer.

**Layer 3: (Rule layer)** Each node (each neuron) in this layer performs the pre-condition matching of the fuzzy rules, i.e., they compute the activation level of each rule, the number of layers being equal to the number of fuzzy rules. Each node of these layers calculates the weights which are normalized.

**Layer 4: (Defuzzification Layer)** It provides the output values “y” resulting from the inference of rules. Connections between the layers 13 & 14 are weighted by the fuzzy singletons that represent another set of parameters for the neuro fuzzy network.

**Layer 5: (Output Layer)** It sums up all the inputs coming from the layer 4 and transforms the fuzzy classification results into a crisp values.

The ANFIS structure is tuned automatically by least-square-estimation and back propagation algorithm. The above mentioned optimization procedures are repeated by using sample data until proper error index or the maximum number of training is achieved. After learning and training, the test data can be used to check the controller to ensure effectiveness of the controller.

#### IV. SIMULATION RESULTS

The simulation which can be done in MATLAB/ SIMULINK 12 shown in Fig.8, Fig.9. The simulation is done for a time of 2seconds. There results has been analyzed for PI and ANFIS controller. The settling time for speed response at 1000 rpm with PI controller is 1.1s which is shown in Fig.4. The settling time for speed response at 1000 rpm with ANFIS controller is 0.1s which is shown in Fig.6. So that the time response curve of the BLDC motor with ANFIS controller is good compare to PI controller which is shown in Fig.7.

A. The BEMF of the motor with PI controller

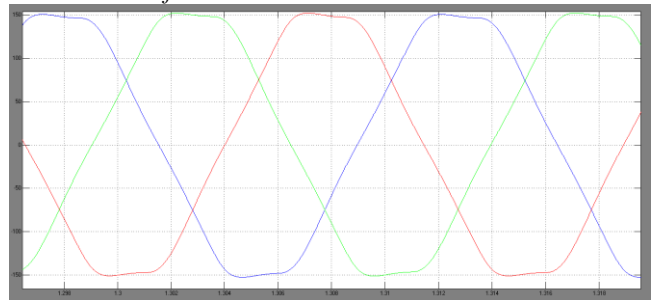

Fig.3. The BEMF of the motor

B. Speed response at 1000 rpm with PI controller

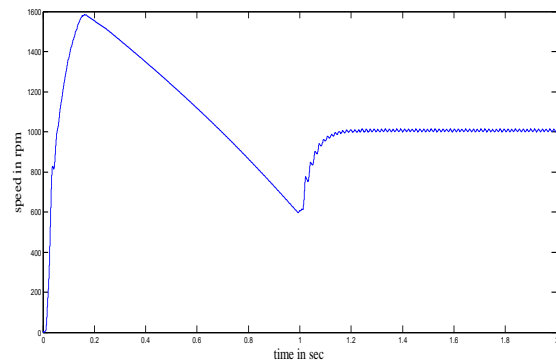

Fig.4. Speed response at 1000 rpm with PI controller

C. The BEMF of the motor with ANFIS controller

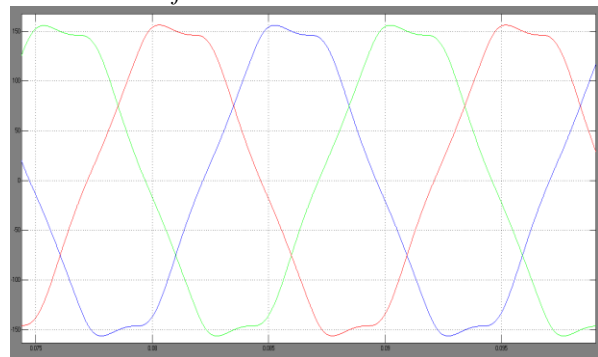

Fig.5. The BEMF of the motor with ANFIS controller

D. Speed response at 1000 rpm with ANFIS controller

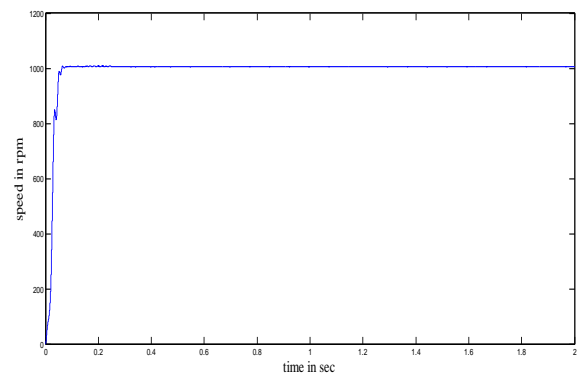

Fig.6. Speed response at 1000 rpm with ANFIS controller

E. Comparison of Speed response at 1000 with PI and ANFIS controller

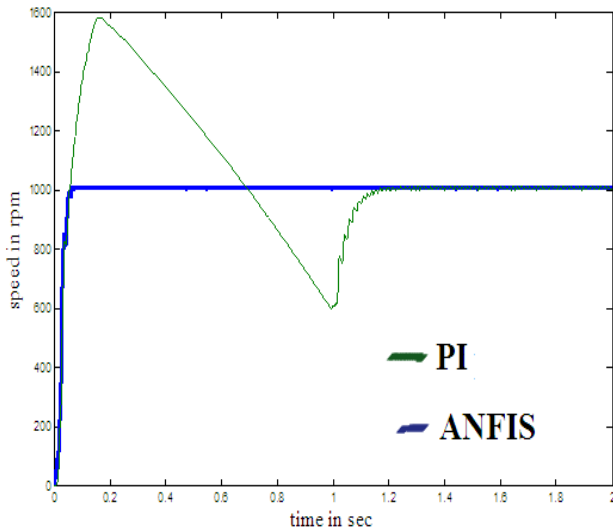

Fig.7. Comparison of Speed response at 1000 with PI and ANFIS controller

Speed Sensorless Control of BLDC Motor Using ANFIS Controller

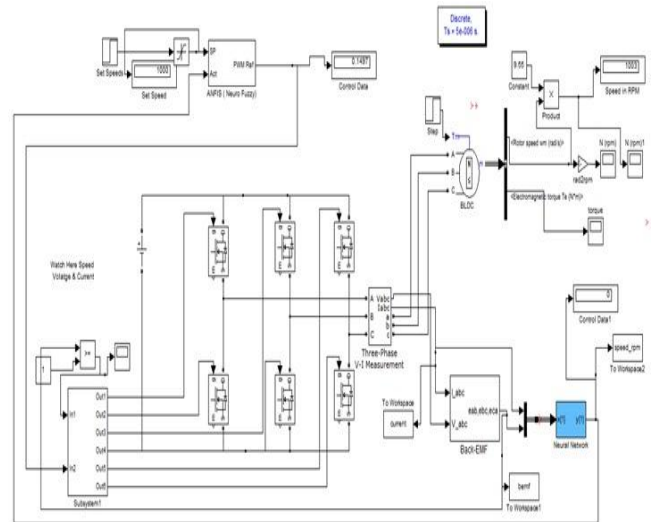

Fig.9. Speed Sensorless Control of BLDC Motor Using ANFIS Controller

Speed Sensorless Control of Bldc Motor Using Pi Controller

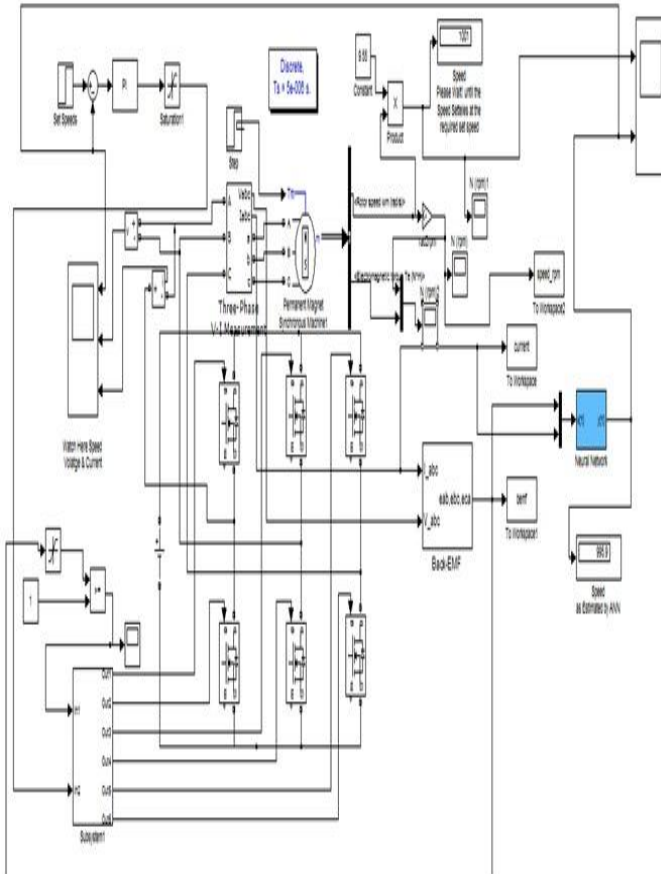

Fig.8. Speed Sensorless Control of Bldc Motor Using Pi Controller

V. CONCLUSION

Speed Sensorless Control of BLDC Motor Using Adaptive Fuzzy Inference System is simulated. Simulation result is presented to verify the effectiveness of the present model. From the result ANFIS neglect the overshoot problem and also improve the time response curve over PI controller for the drive system.

VI. REFERENCES

- [1] Wook-Jin Lee, Student Member, IEEE, and Seung-Ki Sul, "A New Starting Method of BLDC Motors Without Position Sensor", IEEE transactions on industry applications, vol. 42, no. 6, november/december 2006.
- [2] J. X. Shen, Senior Member, IEEE, and S. Iwasaki, "Sensorless Control of Ultrahigh-Speed PM Brushless Motor Using PLL and Third Harmonic Back EMF", IEEE transactions on industrial electronics, vol. 53, no. 2, april 2006.
- [3] Cheng-Tsung Lin, Chung-Wen Hung, and Chih-Wen Liu, "Position Sensorless Control for Four-Switch Three-Phase Brushless DC Motor Drives", IEEE transactions on power electronics, vol. 23, no. 1, january 2008.
- [4] Yen-Shin Lai, Senior Member, IEEE, and Yong-Kai Lin, "Novel Back-EMF Detection Technique of Brushless DC Motor Drives for Wide Range Control Without Using Current and Position Sensors", IEEE transactions on power electronics, vol. 23, no. 2, march 2008.
- [5] P. Damodharan and Krishna Vasudevan, Member, "Sensorless Brushless DC Motor Drive Based on the Zero-Crossing Detection of Back Electromotive Force (EMF) From the Line Voltage Difference", IEEE transactions on energy conversion, vol. 25, no. 3, september 2010.

- [6] K. Iizuka, H. Uzuhashi, M. Kano, T. Endo, and K. Mohri, "Microcomputer control for sensorless brushless motor," *IEEE Trans. Ind.Applicat.*, vol. IA-21, pp. 595–601, May/June 1985.
- [7] S. Ogasawara and H. Akagi, "An approach to position sensorless drivefor brushless dc motors," in *Conf. Rec. IEEE-IAS Annu. Meeting, 1990*, pp. 443–447.
- [8] J P. J. Costa Branco and J. A. Dente, "An experiment in automatic modeling an electrical drive system using fuzzy logic," *IEEE Trans. Syst.Man Cybern.*, vol. 28, no. 2, pp. 254–262, Mar. 1998.
- [9] J.-S. R. Jang, "ANFIS: Adaptive-network-based fuzzy inference systems," *IEEE Syst., Man, Cybern. C*, vol. 23, no. 3, pp. 665–685, May 1993.