

DYNAMIC RESPONSE ANALYSIS OF AN AUTOMOTIVE CRANKSHAFT

Sunil Kumar C R P¹, Chandan R²

¹M.Tech Scholar, ²Assistant Professor, Department of Mechanical Engineering
Dr. Ambedkar Institute of Technology Bangalore, Karnataka, India

Abstract: Presently Scania utilizes a standard method for dynamic calculations that depends on a frequency response approach. A deliberate or ascertained excitation yields a specific reaction through the exchange capacity of the framework. The exchange capacity is gotten through an eigenfrequency figuring and an experience based evaluation of the modular damping. A conspicuous disadvantage of this method is that the evaluated modular damping emphatically influences the figured reaction of the framework. In this thesis, the method laid out above is contrasted with an option, purported, reverse method in which the excitation of the framework is figured utilizing a deliberate reaction. The point of interest is that the modular damping does not influence the outcome straightforwardly since the excitation has been balanced by reaction. As a show protest a charge air channel and its section are utilized. The figured security element of the exhibition item is sensible for both the standard method and the reverse method. An evaluation of the nature of the model is acquired for the reverse method through factual measures, which is not the situation for the standard method. The excitation for the converse method is changed in accordance with the evaluated modular damping which is a noteworthy point of preference since damping is famously difficult to measure in building hone. The converse method has ended up being a valuable recreation method for figuring's when a model of the motor segment of interest as of now exists.

I. INTRODUCTION

Crankshaft is a segment without limits with a confusing geometry engine, which changes over the relocation of the camera respond to improved rotation with an instrument four affiliation. Since the crankshaft is unlimited cycle among his associational life, fatigue and the nature of implementation of this part they should be considered in the course of the framework. the movements of the plot have been a key issue reliably industry crank timing to produce a less costly basis weight section with the quality of the conceivable and appropriate fatigue and other essential utilities. These movements result in lighter and more humble engines with better fuel viability and increased strength performance. The crankshaft, an accessory bar, and the camera are a slider-key four bars, which changes on the progress of sliding cylinder (slider in the structure) to improved turning tool. Since performance in turn is more utilitarian and material for service to different devices, the graphic engine thinking about is that performance comes on. Also, clear line of an engine is

not smooth, like emptying is done by the gas jet in the ignition chamber. Thusly, sudden eviction has Deaden and use of this dedication to another contraption can hurt her. The use of the crankshaft is a sudden changed this performance smooth rotation that is dedication to different devices, per occurrence, generators, pumps and compressors moving. It is in such a way that it is demonstrated that the use of a flywheel helps soften support.

Discretization Of Problem

All real life objects are continuous means there is no physical gap between any two consecutive particles. According to material science, any article is comprised of little particles, particles of atoms, particles of ions thus on and they are fortified together by power of fascination. Tackling a genuine issue with consistent material methodology is troublesome and essential of every single numerical strategy is to streamline the issue by discretizing it. In simple words nodes work like atoms and with gap in between -filled by an entity called as element. Calculations are made at nodes and results are interpolated for elements.

Stress concentration

Stress concentration refers to the intensification in the voltage esteem because of the nearness of splits, discontinuities or cut outs in an area of a material. The anxiety focus variable is a straightforward measure of the degree to which an outside voltage is increased by the nearness of the irregularity. Changes in the cross area causes restricted anxiety fixations and seriousness relies on upon the geometry of the intermittence and the way of the material.

Methods of reducing stress concentration:

A number of methods are available to reduce the stress concentration in parts of the machine, including:

- Provide a fillet radius so that the cross section may gradually change.
- Using an elliptical fillet.
- The use of a number of small notches instead of one long, if a notch is inevitable.
- The use of narrow notches instead of wide notches, if a projection is unavoidable.
- The use of slots to relieve stress.

II. OBJECTIVE OF THE PROBLEM

The objective of this study is to determine the total stress developed on the crank shaft due to the dynamic load applied on the crank shaft due to the power generated during the power stroke and also to study the effects of buckling load of

the same magnitude as that of the power stroke applied on the connecting rod from the power stroke of a Spark-ignition engine.

A. Methodology

- Geometry of a crank shaft will be modelled using modelling software (CATIA v5).
- The Generated CAD Model is then discretize and a Finite Element Model will be created using a Pre-Processor (Hyper Mesh).
- The loads and boundary conditions that were calculated will be applied on the FE Model during Pre-Processing.
- The generated solver deck is fed to a solver (NASTRAN)
- Post-processing of the results obtained is performed with Post-processor (Hyper View).

B. Modelling

The geometrical model of a crankshaft used in a two-cylinder engine SI. The modeling was performed using the modeling software, CATIA V5. It contains an end of the piston rod and one end of crankshaft divided into two parts to facilitate installation. For simplification model, all fillets and chamfers below 3 mm are neglected and the final model. The cane is a section I of the section with the smaller end at the end variable piston and larger section at the end of the crankshaft.[1]

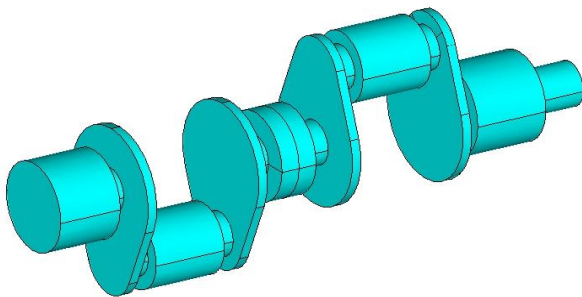

Fig. 1. Geometric model of crankshaft.

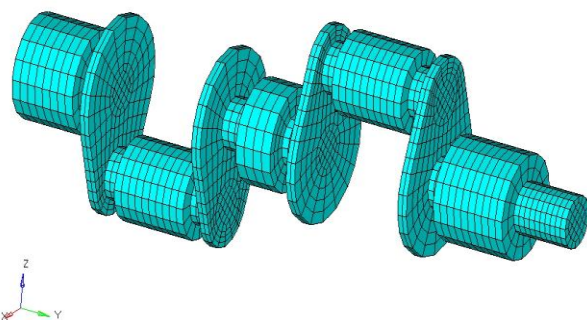

Fig. 2. Finite Element Model of the crankshaft.

The geometric model shown in the previous section is discretizing using tetrahedral elements. These elements are selected because of their ability to capture the geometry of any complex model. Since this model is of various shapes and sizes, a tetra element of the first order is selected. The figure also shows the element sizes used for each of the complex shapes in the model and the average size of the elements was taken as 5mm.

C. Material property

Material property		
Property	unit	value
Youngs' Modulus	GPa	206.7
Density	Kg/m3	7820
Ultimate strength	MPa	827
Poisson's Ratio	-	0.3

Table 1 gives the material properties applied to the model. The material is forged steel and its properties are given below. The material properties required for the current analysis are Young's Modulus, Poisson's ratio and density. This is because the analysis is of structural nature and other properties are not considered in the analysis.

D. Elements and nodes counts

Nodes	6720
Elements	5073

Table 2 gives the number of nodes and elements generated during the discretization. The total mass of thee model is seen to be around 3.43 kg which is close to the actual value.

E. Boundary Conditions and load calculation of cranck shaft

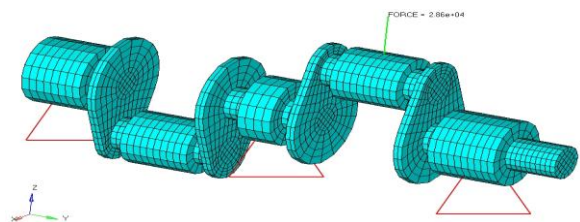

Figure. 3. Finite Element model of crank shaft with Loads and Boundary conditions

Figure 3 shows the discretize model with loads and boundary conditions applied. For this analysis, the connecting rod is placed at the top dead center during the commencement of the power stroke. Hence, the crank is constrained in all degrees of freedom and the load is applied on the piston end of the connecting rod. [2]

F. Results and Discussion

The analysis was run for the above mentioned FE Model with the loads and boundary conditions attached to it. The following figures give the results obtained from the analysis of the crankshaft for the given modes in which the shapes of the crankshaft changes.

Table Eigen values and frequencies

Mode	Frequency	Eigenvalue
1	1.483728E-02	8.690970E-03
2	8.799193E+02	3.056648E+07
3	9.154451E+02	3.308448E+07
4	1.042517E+03	4.290682E+07
5	1.106260E+03	4.831413E+07
6	1.264364E+03	6.311080E+07
7	2.350193E+03	2.180553E+08
8	2.355161E+03	2.189782E+08
9	2.785456E+03	3.063037E+08
10	3.586084E+03	5.076924E+08
11	4.781794E+03	9.026959E+08
12	4.823441E+03	9.184882E+08

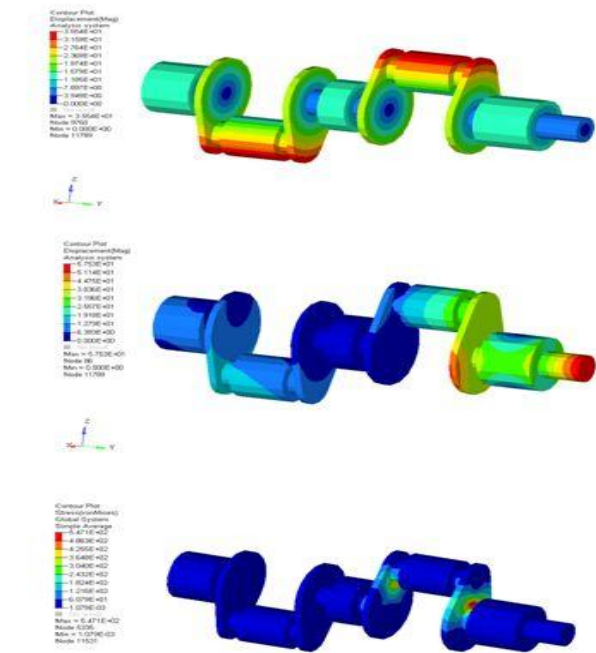

Fig. 6. Elemental stress plot

Figure 6 shows the voltage above Von Mises plot of a crankshaft connected under piles. It follows from the above that assume the greatest anxiety is close to the pin of the key in an estimate of 547.1MPa. This quality is particularly not exactly the quality of flow of the material and then can be said that the interface flow pole is protected under the load connected to the light of the fact that the estimation of anxiety created is well within the level of anxiety extreme right a final quality of 827MPa.[3]

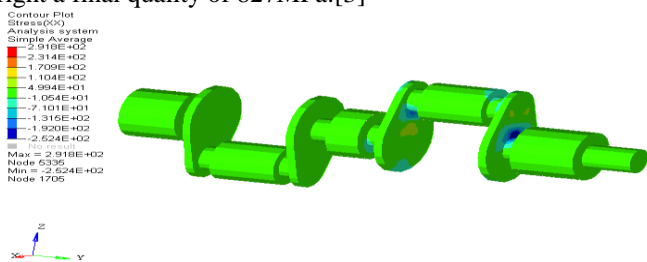

Figure 7 – Elemental stress plot in X-direction

Figure 7 shows a graph of anxiety in the X-course of a crankshaft connected loads. It can be seen that the

improvement in the crankshaft weight falls under the scope of - 252.4MPa and 49.94MPa. Also Figure 7 shows a stress plot in the X-direction of a crankshaft for the applied loads. It can be seen that the development of stress on the crankshaft falls under the range of -252.4MPa and 49.94MPa.

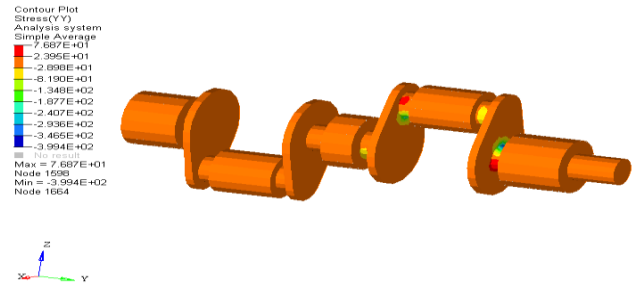

Figure 8 – Elemental stress plot in Y-direction

Figure 8 shows a stress plot in the Y-direction of a crankshaft for the applied loads. It can be seen that the development of stress on the crankshaft falls under the range of -187.7MPa and 76.87MPa [4].

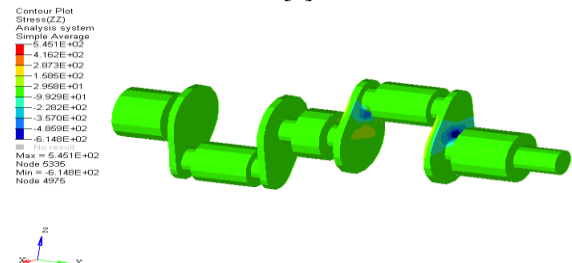

Figure 9 – Elemental stress plot in Z-direction

Figure 9 shows a stress plot in the Z-direction of a crankshaft for the applied loads. It can be seen that the development of stress on the crankshaft falls under the range of -614.2MPa and 29.58MPa.

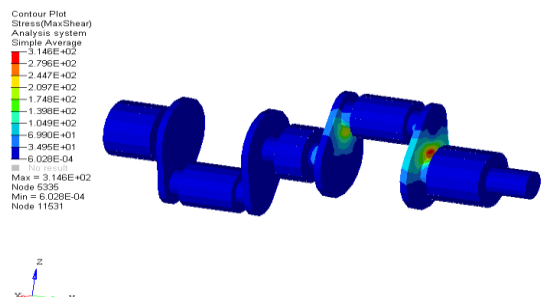

Figure 10 – Maximum Shear stress plot

Figure 10 shows the shear stress plot for a crankshaft under the applied loads. It is seen that a maximum stress value of 314.6MPa is obtained on the crankshaft since it experiences two opposite forces.[5]

III. CONCLUSION

A forged steel crank shaft was analyzed using Finite Element Analysis to understand its behavior under dynamic loading conditions. The geometry created using CATIA v5 software was discretize and the FE model was generated using Hyper Mesh software. Load calculations show the region of load application and the results were recorded.

Based on the results we can say that,

- The stress level in the crankshaft falls below the yield strength of the material and hence is safe under the applied loads.
- The displacement occurring for the applied loads does not affect the performance of the crankshaft.
- The stress plots in X, Y and Z-Directions show that the stresses developed do not affect the performance of the crankshaft.

Scope of future work

The present work only deals with some aspects of the analysis and not any other analyses. So, the same model can be further analyzed and modified based on the results of the analyses.

- Further research in material science may yield materials with better properties to replace steel.
- Dynamic analyses may generate results which could assist in modification of the connecting rod for better performance.
- Optimization of the present model based on the results obtained.

REFERENCE

- [1] Pai, C. L., 1996, "The shape optimization of a connecting rod with fatigue life constraint," *Int. J. of Materials and Product Technology*, Vol. 11, No. 5-6, pp. 357-370.
- [2] FEM analysis of connecting rod by R.Vozenilek,C.Scholz (The Technical University of Liberec,Halkova)
- [3] Rabb, R., 1996, "Fatigue failure of a connecting rod," *Engineering Failure Analysis*, Vol. 3, No. 1, pp. 13-28.
- [4] Park, H., Ko, Y. S., Jung, S. C., Song, B. T., Jun, Y. H., Lee, B. C., and Lim J. D., 2003, "Development of Fracture Split Steel Connecting Rods," *SAE Technical Paper Series*, Paper No. 2003-01-1309.
- [5] Pravardhan S. Shenoy, "Dynamic load analysis and optimization of connecting rod", 2004, Master's thesis, University of Toledo.