

## AN APPROACH FOR POWER QUALITY IMPROVEMENT

Khushwinder Singh Brar<sup>1</sup>, Hartej Singh Saini<sup>2</sup>, Harinder Singh Sandhu<sup>3</sup>  
<sup>1,2</sup>M.Tech (EE), <sup>3</sup>Assistant Professor  
AIET, Faridkot

**Abstract:** According to increase demand of electrical energy in world we need to power quality improvement. Mostly power electronic based equipment are used in industrial and domestic applications for controlling purpose for so in this paper we discuss about power quality, advantage of power quality, cost of poor power quality, reason of bad power quality and how to it is improved.

**KEYWORD:** DSTATCOM, PWM (pulse width modulation), Power quality

### I. INTRODUCTION

Now a day's power electronic based equipment are used in industrial and domestic purpose. As industrial automation continues to evolve with the introduction of computer based control systems, the importance of AC power quality has been lower. The inclusion of more sensitive electronic equipment in industrial processes demands the delivery of clean and stable power. The best electrical supply would be a constant magnitude and frequency sinusoidal voltage waveform. However, because of the non-zero impedance of the supply system, of the large variety of loads that may be encountered and of other phenomena such as transients and outages, the reality is often different. These equipments have significant impacts on the quality of supplied voltage and have increased the harmonic current pollution of distribution systems. So we need to improve the voltage profile and power quality. In a power distribution networks, reactive power is the main cause of increasing distribution system losses and various power quality problems. Conventionally, static var compensators (SVC) have been used in conjunction with passive filters at the distribution level for reactive power compensation and mitigation of power quality problems [1]

#### A. IMPORTANCE OF POWER QUALITY

- Power quality is defined by the parameters that express load unbalance, harmonic pollution, and reactive power.
- The best ideal electrical supply would be a sinusoidal voltage waveform with constant magnitude and frequency.
- The power quality of the network is good then any load connected to it will run satisfactorily and efficiently.
- The power quality of the network is bad, then installation during cost and carbon footprint will be maximum and it's vice versa.
- If the power quality of the network is bad, then loads connected to it will fail and the efficiency of the electrical installation will reduce.

#### B. COST OF POOR POWER QUALITY

Poor Power Quality can be described as any event related to the electrical network that ultimately results in a financial loss. Possible consequences of Poor Power Quality include the followings:

- Unexpected power supply failures means breakers tripping and fuses blowing.
- Equipment failure.
- Equipment overheating means motor, transformer etc.
- Damage to sensitive equipment means PCs, production line control systems.
- Electronic communication interferences and increase the system losses.
- Health issues with and reduced efficiency of personnel.

Low Voltage poor Power Quality can be defined as:

- Reactive power, as it loads up the supply system unnecessary,
- Harmonic pollution, as it causes extra stress on the networks and makes installations run less efficiently,
- Load imbalance, especially in office building applications, as the unbalanced loads may result in excessive voltage imbalance causing stress on other loads connected to the same network, and leading to an increase of neutral current and neutral to earth voltage build-up,
- Fast voltage variations leading to flicker.

### II. REASON FOR VOLTAGE DROP AND BAD POWER QUALITY LOSSES:

#### A. Harmonics

At present, the network components are failing because of poor PQ. On the other hand, it is often found that extra losses are occurring in the network components because of additional harmonic currents in the network. Power system harmonics is an area that is receiving a great deal of attention recently because due to the fact that non-linear means harmonic producing loads are comprising an ever-increasing portion of the total load for a typical industrial plant. The increase in proportion of non-linear load has prompted more stringent recommendations in IEEE Std. 519 and stricter limits imposed by utilities. Incidence of harmonic related problems is not high, but awareness of harmonic issues can help to increase plant power system reliability. On the rare chances that harmonics are a problem, because due to the magnitude of the harmonics produced or a power system resonance.

### B. Voltage dips

A voltage dip event can disrupt the operation of sensitive devices that might lead to partial and complete interruption of a customer's power supply. The effects of voltage mainly depends on the type of consumer, the usage of the power supply and the electricity demand of the installation. Voltage dips when disconnected from the supply then a plant can be completely disconnected from its supply and be re-connected again in a few second. The supply voltage can be as low as zero during the time the plant is disconnected. Voltage dips can occur while connected to the supply system. The data for the dip is taken from [2]. An event of this kind can cause problems to users of electronic, and other, equipment connected to the grid. The degree of effect the dip has on the equipment depends on the severity of the dip, but also on the possibility of the equipment to withstand the dip.

### C. Flicker-

Power-line flicker is a visible change in brightness of a lamp because rapid fluctuations in the voltage of the power supply provided by the source. The voltage drop is generated over the source impedance of the grid by the changing load current of an equipment. These fluctuations in time generated flicker. The effects can range from disturbance to epileptic attacks of photosensitive persons. Flicker is affect electronic equipment such as television received or industrial processes relying on constant electrical power.[3] In general, the main cause of these effects is switching operations of industrial processes and electrical appliances connected to the supply system. Electrical equipment can often have complex program cycles which cause the current drawn from the provided supply to fluctuate. A washing machine will switch on and off current to heat the water there will be a surge of current as the motor starts to turn and varying current as the motor speed is controlled. The current is flocculate which is flows through the network impedance and induces a voltage drop which changes at the same rate as the current

### D. Common power problem-

- *Power surge-* A power surge takes place when the voltage is 110% or more above normal. The power surge is occurred due to heavy electrical equipment being turned off.
- *High voltage spike-* High-voltage spikes occur when there is a sudden voltage peak of up to 6,000 volts. These spikes are nearby lightning strikes and these spikes can be other causes as well. The effects on sensitive electronic systems can include loss of data and burned circuit boards.
- *Transient-* Switching transients take place when there is a rapid voltage peak reach or up to 20kv with duration of 10 microseconds to 100 microseconds. The cause of its occurring is arcing faults and static discharge.
- *Frequency variation-* It involves a change in frequency from the normally stable utility frequency of 50 Hz or 60 Hz, depending on the frequency standard of geographical location. This may be

caused by random operation of emergency generators or unstable frequency power sources.

- *Power sag-* Sag is the reduction of AC Voltage at a given frequency for the duration of 0.5 cycles to 1 minute's time. These are usually caused by system faults, and the result of switching on loads with high demand start-up currents.
- *Electric line noise-* It is defined as Radio Frequency Interference (RFI) and Electromagnetic Interference (EMI) and causes undesirable effects in the circuits. The electric motors, relays, motor control devices, broadcast transmissions, microwave radiation, and distant electrical storms. RFI, EMI include in the source of problem and data error, data loss, storage loss, keyboard lockup and system lockup occur other frequency problem.

## III. POWER QUALITY IMPROVEMENT TECHNIQUE

### A. Use of PWM technique-

The energy that a switching power converter delivers to a motor is controlled by Pulse Width Modulated (PWM) signals applied to the gates of the power transistors. When a PWM signal is applied to the gate of a power transistor then the turn on and turns off intervals of the transistor to change from one PWM period to another PWM period according to the same modulating signal. PWM signals are pulse trains with fixed frequency and magnitude and variable pulse width. The frequency of a PWM signal must be much higher so the cause of it the modulating signal, the fundamental frequency means the energy delivered to the motor and its load depends mostly on the modulating signal [4]. The conventional Regular Sampled PWM technique can be simply extended to allow Harmonic Minimization and also Harmonic Elimination PWM to be closely reproduced using simple algebraic equations. The power devices for input current wave shaping is controlled by PWM switching pattern so that it becomes almost harmonic-pollution free and in phase with the source voltage, thus producing a nearly sinusoidal supply current at unity power factor without the need of any passive or active filter for harmonics and reactive power compensation. The proposed method, which is named selective harmonic mitigation PWM, with high quality generates switching three-level PWM patterns from the point of view of harmonic content, avoiding the elimination of some specific harmonics and studying all harmonics and the total harmonic distortion as a global problem by using a general-purpose random-search heuristic algorithm. This fact leads to avoidance of the bulky and costly grid connection tuned filters of power systems

### B. The advantage of PWM based upon switching power converter over linear power amplifier is-

- Easy to implement and control,
- No temperature variation-and ageing-caused drifting or degradation in linearity,
- Compatible with today's digital microprocessors,
- Lower power dissipation, and

- It allows linear amplitude control of the output voltage/current from previously not present.

C. Disadvantage of PWM-

- Attenuation of the wanted fundamental component of the PWM waveform, in this case from 1.1-0.866<sup>pu</sup>.
- Drastically increased switching frequencies (in this case from 1 pu to 21 pu)-this means greater stresses on associated switching devices and therefore derating of those devices
- Generation of high-frequency harmonic components.

D. The basic PWM techniques are-

1. Single Pulse Width Modulation
2. Multi Pulse Width Modulation
3. Sinusoidal Pulse Width Modulation (SPWM)

E. Use of DSTATCOM-

A DSTATCOM is a controlled reactive source. The operating principles of DSTATCOM are based on the exact equivalence of the conventional rotating synchronous compensator. DSTATCOM includes a voltage source converter (VSC) and a DC link capacitor connected in parallel, capable of generating and absorbing reactive power. The AC terminals of the VSC are not connected to the point of common coupling (PCC) through an inductance, which could be a filter inductance or leakage inductance of the coupling transformer, as shown in figure 1.

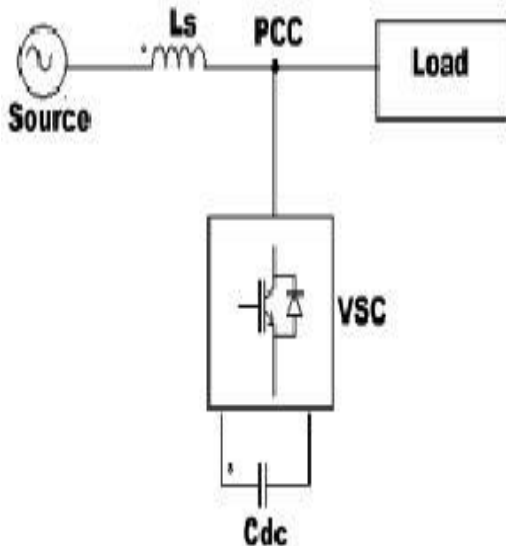

Figure 1: Basic Structure of Dstatcom

The DC side of the converter is connected to a DC capacitor and capacitor carries the input ripple current of the converter and charged by a battery source, or could be recharged by the converter itself. This capacitor is the main reactive storage element. If the output voltage of the VSC is equal to the AC terminal voltage that means no reactive power is delivered to the system. If the output voltage is greater than the AC terminal voltage, the DSTATCOM is in the capacitive mode of operation and vice versa.

IV. CONCLUSION

Power quality improvement is required. Power quality is improved with the help of Pulse Width Modulation technique and DSTATCOM technique. With the help of this technique we can minimize the harmonic, voltage dip, flickers and common power problem.

REFERENCE

- [1] J.Dixon, L.Moran, and Rodriguez, Reactive power compensation technologies: state of art Review, proceedings of the IEEE.vol.93.No.12, 2005.
- [2] Bollen, M.H.J., Understanding power quality problems: voltage sags and interruptions, 2000, online material at ftp.ieee.org/uploads/press/Bollen
- [3] IEEE Standard 519 Recommended Practices and Requirements for Harmonic Control in Electrical Power Systems section 10.5 Flicker
- [4] Zhenyu Yu Arefeen Mohammed Issa Panahi “ A Review of Three PWM Techniques”American Control Conference, New Mexico, June 1997.