

SIMULATION BASED ANALYSIS OF HYBRID WIND-SOLAR ENERGY SYSTEMS.

Abhishek Chauhan¹, Prof. Harshkumar S. Sharma²

¹PG Scholar, Electrical Engineering Department, Hansaba College of Engineering & Technology, Gokul Global University, Sidhpur, Gujarat, India

²Assistant Professor, Electrical Engineering Department, Hansaba College of Engineering & Technology, Gokul Global University, Sidhpur, Gujarat, India

Abstract: Solar and wind are the most popular resources due to its ease of availability and its ease conversion into electricity. Each renewable resource require DC/DC boost converter with MPPT control for power generation. To obtain high efficiency of photovoltaic (PV) system and wind energy system, the maximum power point tracking (MPPT) technology is employed. Perturb and Observe MPPT technique is used for PV system in which dc voltage is used as perturbation variable. While in wind energy system, perturbation variable as a dc current is used in modified perturb and observe MPPT algorithm. Modified perturb and observe algorithm is stable and tracks fast for sudden wind speed change conditions. Maximum Power Point Tracking (MPPT) technique used with boost converter extracts maximum power from the source when it is available. Simulation of both the renewable energy sources is carried out separately in PSIM 9.0 with different MPPT types of techniques.

I. INTRODUCTION

Due to the critical condition of industrial fuels which include oil, gas and others, the development of renewable energy sources is continuously improving. This is the reason why renewable energy sources have become more important these days. Few other reasons include advantages like abundant availability in nature, eco-friendly and recyclable. Many renewable energy sources like solar, wind, hydel and tidal are there. Among these renewable sources solar and wind energy are the world's fastest growing energy resources. With no emission of pollutants, energy conversion is done wind and PV cells. Day by day, the demand for electricity is rapidly increasing. But the available base load plants are not able to supply electricity as per demand. So these energy sources can be used to bridge the gap between supply and demand during peak loads. This kind of small scale stand-alone power generating systems can also be used in remote areas where conventional power generation is impractical. In this paper, simulation of solar energy system and wind energy system with MPPT technique is done separately. MPPT technique is employed with DC/DC converter to turn on/off the controlled switch of the boost converter. Simulation is carried out in PSIM 9.0. MPPT algorithm used for the PV system is perturb and observe algorithm which is adopted from PSIM renewable examples while MPPT algorithm for wind energy system was programmed in visual C++ from the proposed modified

perturb and observe algorithm in [6]. Results are compared by changing input conditions of sources like for PV system- irradiance and for wind system- wind speed, and output is observed. With different input conditions, power generated from these sources must be equal to power delivered to the load which is shown in simulation results.

II. SIMULATION OF WIND ENERGY SYSTEM

The schematic diagram of the wind energy system to which the MPPT applied is shown in Fig.1. Generator used is of permanent magnet synchronous generator type which is directly coupled to turbine due to its advantages like no need of gear box, small size, very less maintenance cost, no requirement of excitation current[6]. Instead of using three-phase controlled rectifier, diode bridge rectifier is used which converts the AC to a DC by rectifying voltage at

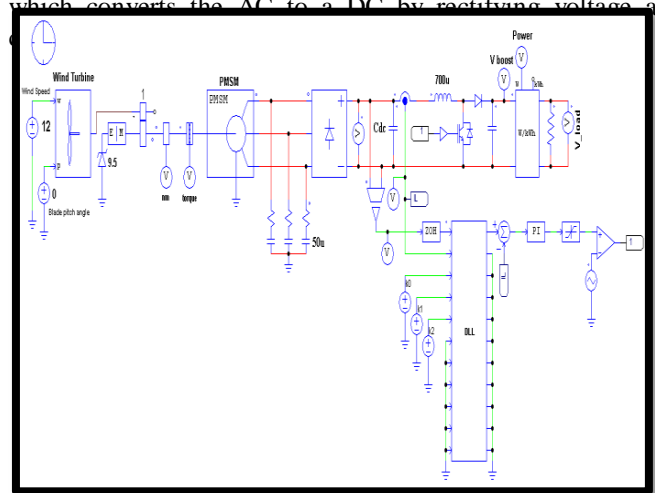

Fig. 1 Wind energy Energy

A. MPPT tracking for varying wind speed

Fig.2 shows variation in different parameters like power, voltage and current with change in wind speed. The system starts with 8 m/s wind speed at which power starts increasing and achieves MPP and becomes constant. Also load current and load voltage starts increasing as shown in Fig.6. Then wind starts increasing and its speed becomes constant 12 m/s after some time. During this sudden change in wind speed, dc voltage increases which leads to the algorithm in

prediction mode where it proceeds by increasing current with larger steps. After sometime wind speed becomes constant

V. CONCLUSIONS

The simulation of the MPPT technique achieves the maximum power point for wind energy system as well PV system. For a particular irradiance level, maximum power generated by wind generator/PV system is delivered by using MPPT technique at the load. For PV system, perturb and observe MPPT technique is used which works efficiently. For wind energy system, modified perturb and technique adopted from IEEE transactions on energy conversion [6] is used in which with normal wind speed conventional perturb and observe technique is employed and with rapidly wind speed conditions prediction mode is employed. Under rapid wind speed condition, conventional P&O has the direction misleading problems while prediction mode reaches MPP faster.

REFERENCES

- [1] Akhilesh P. Patil, Rambabu A. Vatti and Anuja S. Morankar, "Simulation of wind solar hybrid systems using PSIM," in International Journal of Emerging Trends in Electrical and Electronics Vol. 10, Issue. 3, April-2024.
- [2] Joanne Hui, Alireza Bakhshai, and Praveen K. Jain , "A hybrid wind-solar energy system: A new rectifier stage topology", 978-1-4244-4783-1/10©2010 IEEE.
- [3] Teena Jacob, Arun S, "Maximum power point tracking of hybrid PV and wind energy systems using a new converter topology", 978-1-4673-2636-0/12©2012 IEEE.
- [4] Texas Instrument, "Basic calculation of a boost converter's Power Stage", SLVA372C–November 2009– Revised January 2023.
- [5] Jacob James Nedumgatt, Jayakrishnan K. B. Umashankar S et. al. "Perturb and observe MPPT algorithm for solar PV systems-modeling and simulation".
- [6] Zakariya M. Dalala, Zaka Ullah Zahid, Wensong Yu, Member et. al. "Design and analysis of an MPPT technique for small-scale wind energy conversion systems", in IEEE TRANSACTIONS ON ENERGY CONVERSION, VOL. 28, NO. 3, SEPTEMBER 2022.
- [7] Lei Tang, Wei Xu, Chengbi Zeng et. al. "One novel variable step-size MPPT algorithm for photovoltaic power generation", 978-1-4673-2421-2/12©2012 IEEE.