

GRID-CONNECTED SOLAR PHOTOVOLTAIC SYSTEM FOR THD REDUCTION AND POWER QUALITY IMPROVEMENT

Neha Karautiya¹, Dr. K T Chaturvedi², Dr. Ritu K R³

¹ M.E. Scholar, Department of Electrical Engineering, UIT, RGPV Bhopal

² Associate Professor, Department of Electrical Engineering, UIT, RGPV Bhopal

³ Assistant Professor, Department of Electrical Engineering, UIT, RGPV Bhopal

ABSTRACT

This paper presents a grid-connected solar photovoltaic (PV) system focused on improving power quality using an LCL filter and advanced control techniques. The system employs a DC-DC boost converter and a voltage source inverter (VSI) for efficient power conversion. Simulation results demonstrate that the integration of the LCL filter significantly reduces total harmonic distortion (THD) in both voltage and current compared to the system without a filter. Furthermore, the implementation of a fuzzy logic-based controller enhances dynamic performance and achieves additional reduction in THD, leading to improved stability and power quality. The results confirm that the proposed approach provides a reliable and efficient solution for harmonic mitigation in grid-connected PV systems.

Keywords: *Grid-Connected Solar Photovoltaic (GCPV), Voltage Source Inverter (VSI), LCL Filter, DC-DC Boost Converter. Maximum Power Point Tracking (MPPT).*

1. INTRODUCTION

Grid-connected solar photovoltaic (PV) systems are widely used for clean and sustainable power generation due to increasing energy demand and environmental concerns [1]. In these systems, the DC power generated by the PV array is converted into AC power using a Voltage Source Inverter (VSI) before being supplied to the utility grid [2]. However, power electronic converters and nonlinear loads generate harmonics, voltage fluctuations, and stability issues that degrade the overall power quality of the system [3]. To improve the performance of grid-connected PV systems, control techniques are required for maintaining stable voltage, current regulation, and proper synchronization with the utility grid. Among various controllers, the Proportional-Integral (PI) controller is one of the most commonly used control methods because of its simple structure, easy implementation, and good steady-state performance [4]. The PI controller helps in regulating inverter output current, maintaining the DC-link voltage, and reducing steady-state error in the system [5]. In addition, an LCL filter is connected between the inverter and the utility grid to suppress

harmonics generated by the inverter switching operation. The combination of PI controller and LCL filter significantly improves the power quality and reduces Total Harmonic Distortion (THD) in the grid-connected PV system [6].

This work focuses on the power quality enhancement of a grid-connected solar photovoltaic system using an LCL filter with a PI controller. The proposed system aims to achieve stable inverter operation, improved voltage regulation, reduced harmonic distortion, and efficient power transfer to the utility grid.

2. RESEARCH METHODOLOGY

The proposed methodology is developed to improve the power quality of a grid-connected solar photovoltaic (GCPV) system using an LCL filter and PI controller. In this system, the photovoltaic (PV) array converts solar energy into DC power. A DC-DC boost converter with Maximum Power Point Tracking (MPPT) is used to maintain a stable DC-link voltage and extract maximum power from the PV array. The DC power is converted into AC power using a three-phase Voltage Source Inverter (VSI). A PI controller is employed to control the inverter operation, regulate DC-link voltage, and maintain synchronization with the utility grid. To reduce harmonics generated by the inverter, an LCL filter is connected between the inverter and the grid.

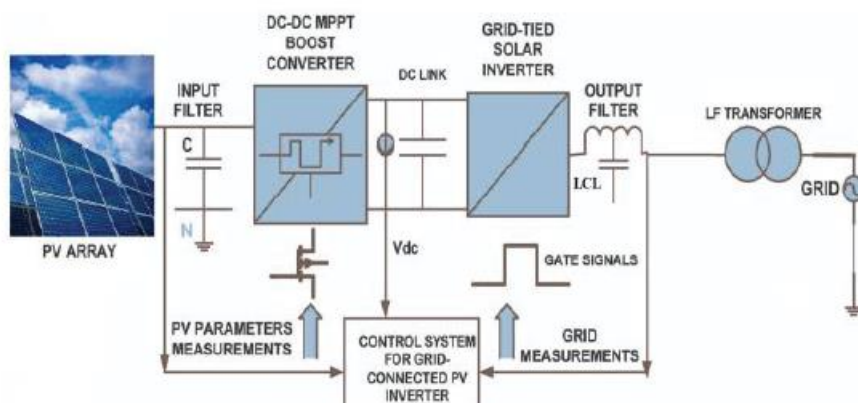

Fig. 1 Grid Connected Photovoltaic (GCPV) System

The Proportional-Integral (PI) controller plays an important role in the grid-connected solar photovoltaic (PV) system by regulating voltage and current, maintaining system stability, and improving power quality. The PI controller continuously compares the reference value with the actual output and generates an error signal to control the inverter operation effectively. In the proposed system, the PI controller performs the following functions:

- Maintains stable DC-link voltage.
- Controls inverter output current.
- Reduces steady-state error in the system.
- Improves dynamic response and system stability.
- Maintains synchronization between inverter and utility grid.

- Helps in achieving unity power factor operation.
- Reduces voltage and current fluctuations.
- Enhances overall power quality of the grid-connected PV system.

The PI controller generates appropriate switching signals for the Voltage Source Inverter (VSI), which ensures smooth power transfer from the solar PV system to the utility grid with reduced harmonic distortion.

3. RESULT AND DISCUSSION

Figure 2 shows the MATLAB/Simulink model of a grid-connected solar photovoltaic (PV) system without an LCL filter. The PV array generates DC power, which is boosted using a DC-DC boost converter. The regulated DC voltage is converted into AC power through a three-phase Voltage Source Inverter (VSI) and supplied to the utility grid. The VSI control block generates switching pulses for inverter operation, while measurement blocks are used to observe voltage, current, and power parameters. Since no LCL filter is used, inverter switching harmonics appear in the output waveform, resulting in higher Total Harmonic Distortion (THD) and reduced power quality. This system is considered the base model for comparison with the proposed filtered system.

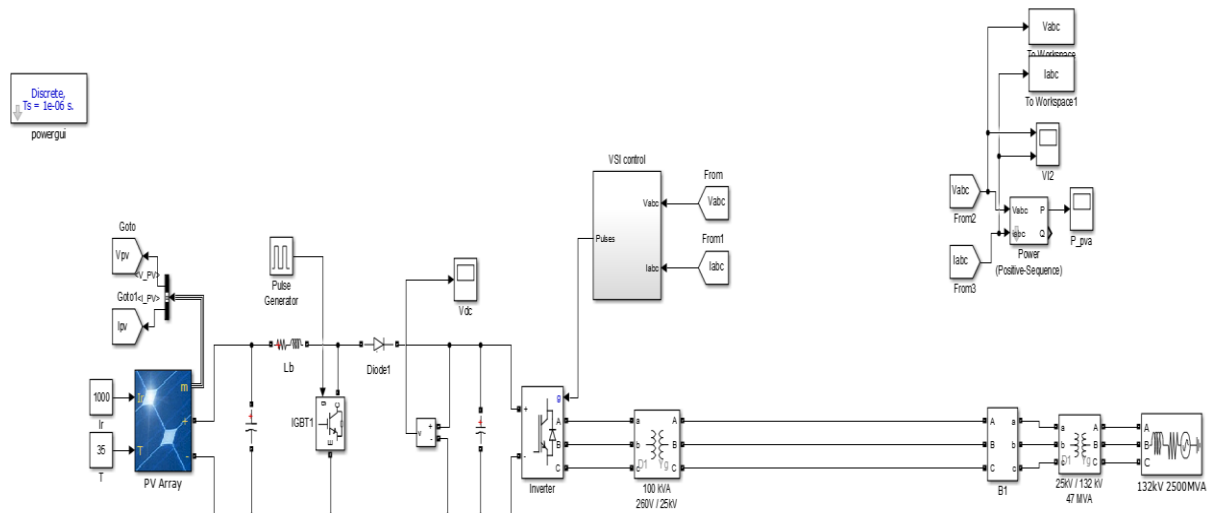

Figure 2 Simulation Model of Grid-Connected Solar PV System without Filter

The PVA unit is linked to the grid without an LCL filter, as shown in Figure 2. The LCL filter coupled to the grid and PVA unit is seen in Figure 3.

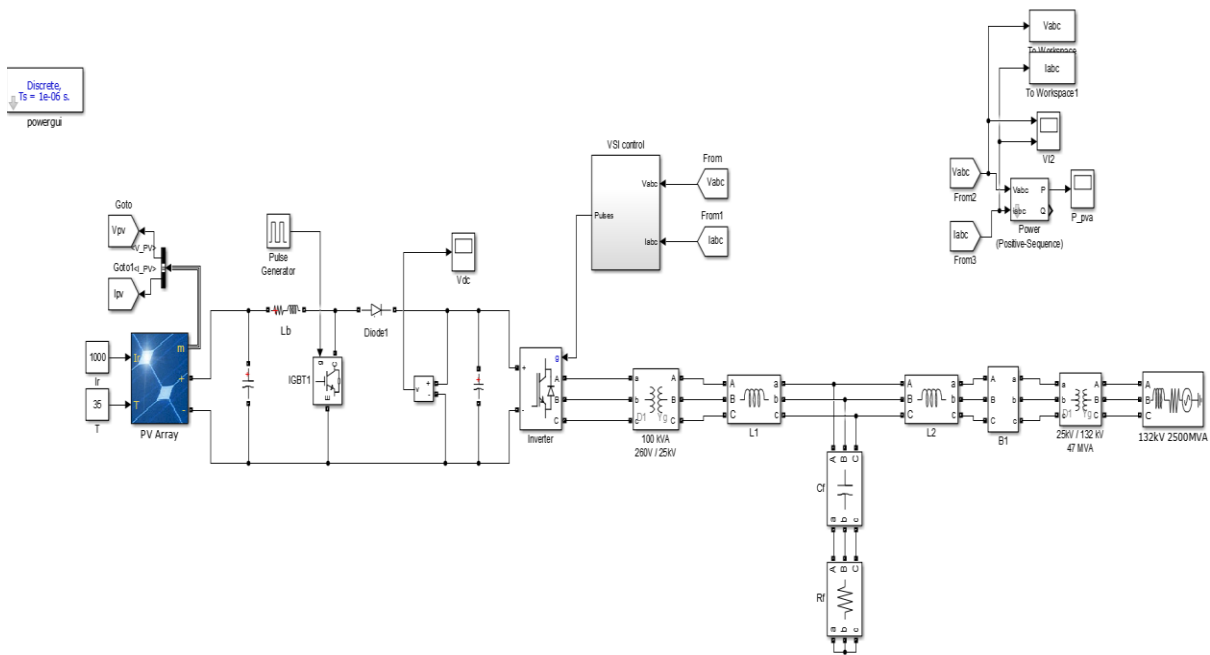

Figure 3 Simulation Model of Grid-Connected Solar PV System with LCL

4.1 HARMONICS ANALYSIS

Without a PI controller, the grid-connected PV system produces higher harmonics due to inverter switching and nonlinear loads, which increases Total Harmonic Distortion (THD) and reduces power quality. With the PI controller, inverter current and DC-link voltage are properly controlled, resulting in smoother voltage and current waveforms. The PI controller reduces THD, improves system stability, and enhances the overall power quality of the grid-connected PV system.

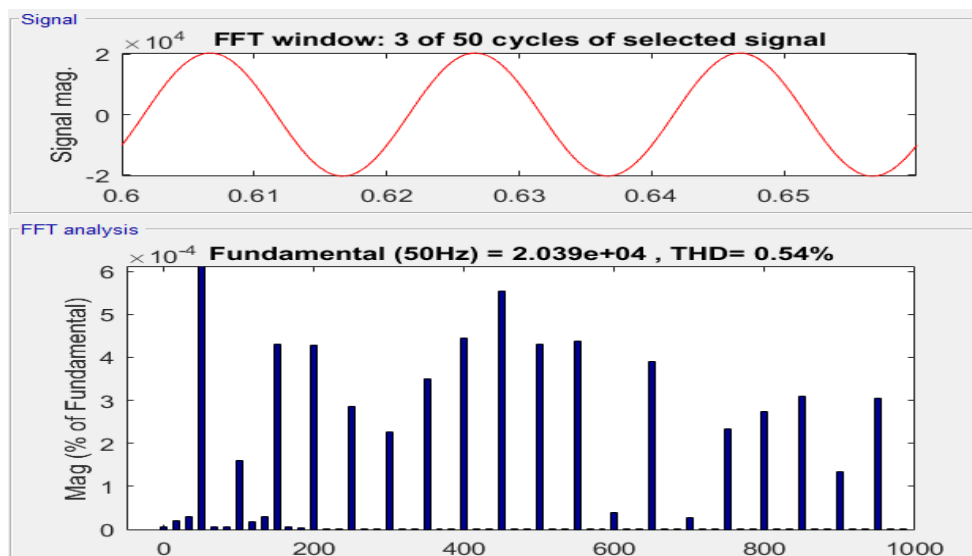

Figure 0 THD of inverter voltage without LCL filter

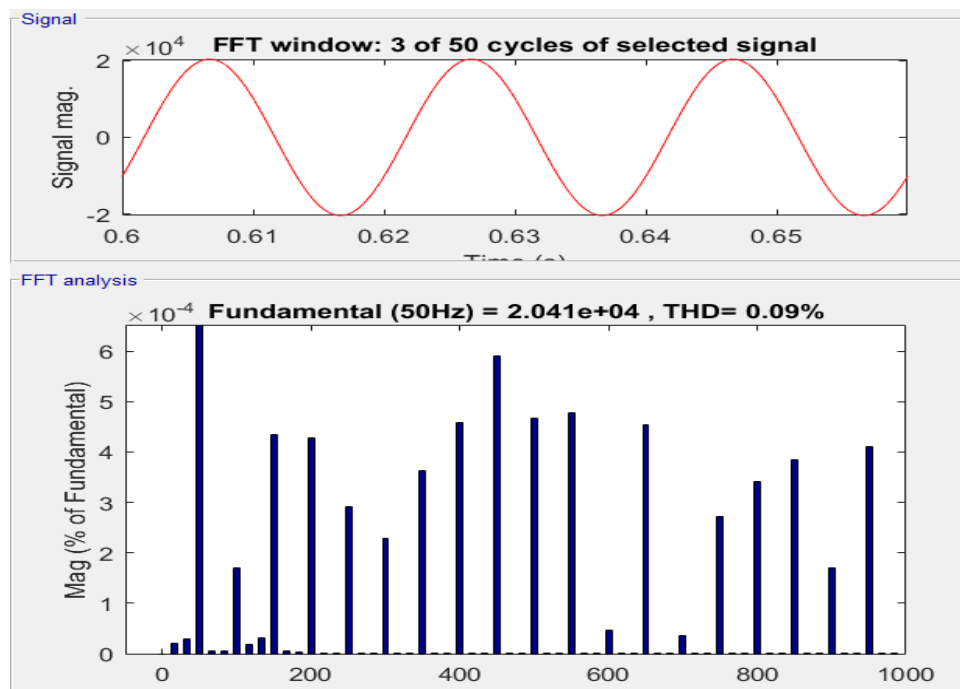

Figure 5 THD of inverter voltage with LCL filter

5. CONCLUSION

In this work, a PI controller-based grid-connected solar photovoltaic (PV) system has been presented for power quality improvement and stable grid integration. The proposed system utilizes a DC-DC boost converter, Voltage Source Inverter (VSI), and PI controller for effective control of DC-link voltage and inverter current. The PI controller successfully maintains system stability, improves dynamic response, and reduces steady-state error during grid-connected operation. Harmonic analysis shows that the use of the PI controller improves the quality of inverter voltage and current waveforms by reducing Total Harmonic Distortion (THD). Simulation results verify that the proposed PI controller-based system provides better voltage regulation, stable power transfer, and enhanced power quality performance. Therefore, the PI controller is an effective and simple control technique for grid-connected solar PV applications.

REFERENCES

- [1] R. D. Amar Raj, T. Aditya, and M. R. Shinde, "Power Quality Enhancement of Grid-Connected Solar Photovoltaic System Using LCL Filter," in *2020 International Conference on Power Electronics & IoT Applications in Renewable Energy and its Control (PARC)*, Mathura, India, 2020, pp. 334–339.
- [2] A. Q. Al-Shetwi, M. Z. Sujod, and F. Blaabjerg, "Low Voltage Ride-Through Capability Control for Single-Stage Inverter-Based Grid-Connected Photovoltaic Power Plant," *Solar Energy*, vol. 159, pp. 665–681, 2020.

- [3] A. Ouai, M. B. Camara, and B. Dakyo, "Fuzzy Logic Control and Hybrid Filtering Strategy for Grid-Connected Photovoltaic Systems," *International Journal of Renewable Energy Research*, vol. 11, no. 2, pp. 654–663, 2021.
- [4] M. Ahmed, A. Ibrahim, and H. Ramadan, "Power Quality Improvement of Grid-Connected Solar System Using Fuzzy PI Controller," *IEEE Access*, vol. 10, pp. 45632–45641, 2022.
- [5] R. Kumar and P. Singh, "Grid Synchronization and Harmonic Mitigation in Solar PV System Using LCL Filter," *International Journal of Power Electronics and Drive Systems*, vol. 14, no. 1, pp. 122–130, 2023.
- [6] S. Belrzaeg and A. Sif, "Modeling and Simulation of Solar Photovoltaic System Using Fuzzy Logic Controller," *Renewable Energy Focus*, vol. 45, pp. 95–104, 2023.
- [7] M. Hosseinpour, A. Rahmani, and H. Karimi, "Power Quality Enhancement in Grid-Connected Solar Arrays Using LCL Filters," *Electric Power Systems Research*, vol. 228, p. 109012, 2024.
- [8] X. Yang, Y. Liu, and Z. Wang, "Fuzzy PI Control of Grid-Connected Solar Inverter with LCL Filter," *International Journal of Electrical Power & Energy Systems*, vol. 156, p. 109678, 2024.
- [9] A. Al-abri, S. Al-Hinai, and M. Al-Badi, "Three-Phase Inverter Control with LC Filter for Grid-Connected PV Applications," *Energy Reports*, vol. 10, pp. 215–223, 2024.
- [10] U. Emeghara, P. Sharma, and K. Verma, "Advanced Two-Stage Grid-Connected PV System with Fifth-Order Boost Converter," *IEEE Transactions on Sustainable Energy*, vol. 16, no. 2, pp. 1120–1130, 2025.
- [11] A. Khaliq, M. Rehman, and S. Khan, "Optimized LCL Filter Design for Harmonic Reduction in Grid-Connected Photovoltaic Systems," *IET Renewable Power Generation*, vol. 19, no. 3, pp. 455–464, 2025.
- [12] H. Mohammed, T. Ali, and R. Hasan, "Fuzzy Logic Controlled Grid-Connected PV System under Variable Climatic Conditions," *Renewable Energy*, vol. 240, pp. 121145, 2025.